

FHA 051 series

Maximum working pressure up to 56 MPa (560 bar) - Flow rate up to 140 l/min



Description

Technical data

High Pressure filters

In-line

Maximum working pressure up to 56 MPa (560 bar)

Flow rate up to 140 l/min

FHA is a range of high pressure filter for protection of sensitive components in high pressure hydraulic systems in the mobile machines. They are directly connected to the lines of the system through the hydraulic fittings.

Available features:

- Female threaded connections up to 3/4", for a maximum flow rate of 140 l/min
- Fine filtration rating, to get a good cleanliness level into the system
- Bypass valve, to relieve excessive pressure drop across the filter media
- Check valve, to protect the system against reverse flow
- Reverse flow valve, to allow bidirectional flow through the filter housing. The back flow is not filtered
- Low collapse filter element "N", for use with filters provided with bypass valve
- Low collapse filter element with external support "R", for filter element protection against the back pressure caused by the check valve or the reverse flow in filters provided with the bypass valve
- High collapse filter element with external support "S", for filter element protection against the back pressure caused by the check valve or the reverse flow in filters not provided with the bypass valve
- Visual, electrical and electronic differential clogging indicators

Common applications:

Delivery lines, in any heavy duty industrial equipment or mobile machines

Filter housing materials

- Head: Steel (chemical heat treatment)
- Housing: Steel (chemical heat treatment)
- Bypass valve: Steel

Pressure

- Test pressure: 84 MPa (840 bar)
- Burst pressure: 168 MPa (1680 bar)
- Pulse pressure fatigue test: 1 00 000 cycles with pressure from 0 to 56 MPa (560 bar)

Bypass valve

- Opening pressure 600 kPa (6 bar) ±10%
- Other opening pressures on request.

Δp element type

- Microfibre filter elements - series N-R: 20 bar
- Microfibre filter elements - series S: 210 bar
- Wire mesh filter elements - series N: 20 bar
- Fluid flow through the filter element from OUT to IN

Seals

- Standard NBR series A
- Optional FPM series V

Temperature

From -25 °C to +110 °C

Connections

In-line Inlet/Outlet

Note

FHA filters are provided for vertical mounting



Weights [kg] and volumes [dm³]

Filter series	Weights [kg]					Volumes [dm ³]						
	Length	1	2	3	4	5	Length	1	2	3	4	5
FHA 051		3.28	3.65	4.06	4.54	5.74		0.33	0.47	0.62	0.79	1.23

Filter series	Length	Filter element design - N Series						Filter element design - R Series					Filter element design - S Series				
		A03	A06	A10	A16	A25	M25	A03	A06	A10	A16	A25	A03	A06	A10	A16	A25
FHA 051	1	42	41	82	85	110	156	42	41	82	85	110	30	40	58	60	76
	2	53	58	87	100	127	158	53	58	87	100	127	45	50	78	91	120
	3	68	71	101	111	137	160	68	71	101	111	137	59	62	92	103	131
	4	86	92	118	121	142	162	86	92	118	121	142	77	83	110	113	137
	5	112	115	137	142	150	165	112	115	137	142	150	96	99	116	128	147

Maximum flow rate for a complete pressure filter with a pressure drop $\Delta p = 1.5$ bar.

The reference fluid has a kinematic viscosity of 30 mm²/s (cSt) and a density of 0.86 kg/dm³.

For different pressure drop or fluid viscosity we recommend to use our selection software available on www.mpfiltri.com.

You can also calculate the right size using the formulas present on the FILTER SIZING paragraph at the beginning of the full catalogue or at the beginning of the filter family brochure.

Please, contact our Sales Department for further additional information.

Hydraulic symbols

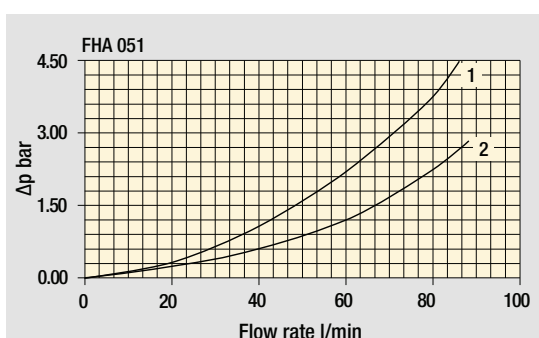
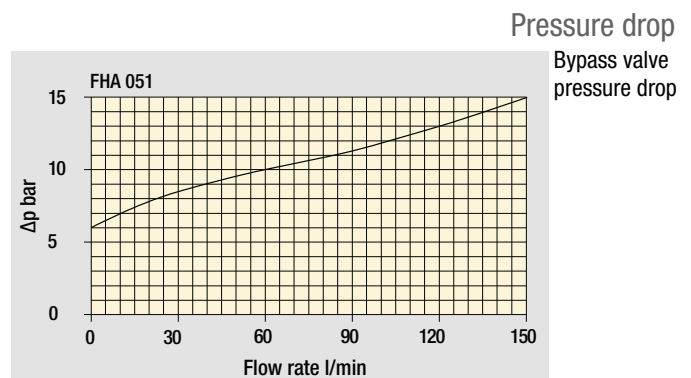
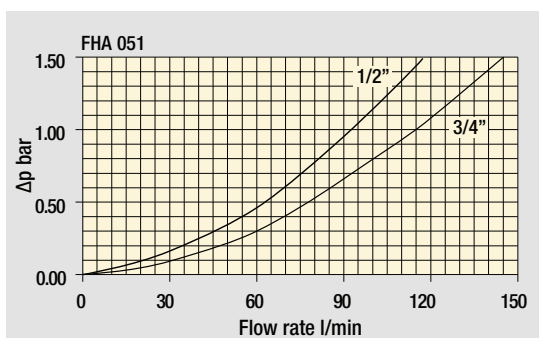
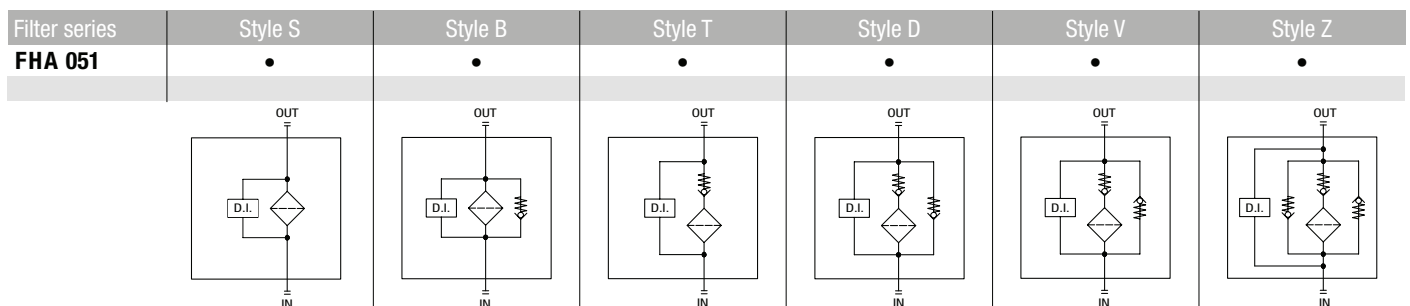

Pressure drop in reverse flow valves

- 1 - Reverse flow
- 2 - In filter direction

The curves are plotted using mineral oil with density of 0.86 kg/dm³ in compliance with ISO 3968. Δp varies proportionally with density.

FHA 051

Designation & Ordering code

COMPLETE FILTER

Series and size Configuration example: **FHA051** **3** **B** **A** **G** **A10** **N** **P01**

FHA051

Length

1 | 2 | 3 | 4 | 5 |

Valves

- S** Without bypass
- B** With bypass 6 bar
- T** With check valve, without bypass
- D** With check valve, with bypass 6 bar
- V** With reverse flow, without bypass
- Z** With reverse flow, with bypass 6 bar

Seals

- A** NBR
- V** FPM

Connections

- | | |
|-----------------------------|-----------------------------------|
| A M18x1.5 - ISO 6149 | E 1/2" NPT |
| B M22x1.5 - ISO 6149 | F 3/4" NPT |
| C G 1/2" | G SAE 8 - 3/4" - 16 UNF |
| D G 3/4" | H SAE 12 - 1 1/16" - 12 UN |

Filtration rating (filter media)

- A03** Inorganic microfiber 3 µm
- A06** Inorganic microfiber 6 µm
- A10** Inorganic microfiber 10 µm
- A16** Inorganic microfiber 16 µm
- A25** Inorganic microfiber 25 µm
- M25** Wire mesh 25 µm

Element Δp	Valves						
	S	B	T	D	V	Z	
N 20 bar		•					
R 20 bar				•		•	
S 210 bar	•		•		•		

Execution

- P01** Upper connection for clogging indicator
- P02** Without connection for clogging indicator
- P03** Frontal connection for clogging indicator
- Pxx** Customized

FILTER ELEMENT

Element series and size Configuration example: **HP050** **3** **A10** **A** **N** **P01**

HP050

Element length

1 | 2 | 3 | 4 | 5 |

Filtration rating (filter media)

- A03** Inorganic microfiber 3 µm
- A06** Inorganic microfiber 6 µm
- A10** Inorganic microfiber 10 µm
- A16** Inorganic microfiber 16 µm
- A25** Inorganic microfiber 25 µm
- M25** Wire mesh 25 µm

Seals

- A** NBR
- V** FPM

Element Δp

- N** 20 bar
- R** 20 bar
- S** 210 bar

Execution

- P01** MP Filtri standard
- Pxx** Customized

ACCESSORIES

Differential indicators	page		page
DEA Electrical differential indicator	567	DLE Electrical / visual differential indicator	570
DEH Hazardous area electronic differential indicator	567-568	DTA Electronic differential indicator	571
DEM Electrical differential indicator	568-569	DVA Visual differential indicator	571
DLA Electrical / visual differential indicator	569-570	DVM Visual differential indicator	571

Additional features

- T2** Plug 572

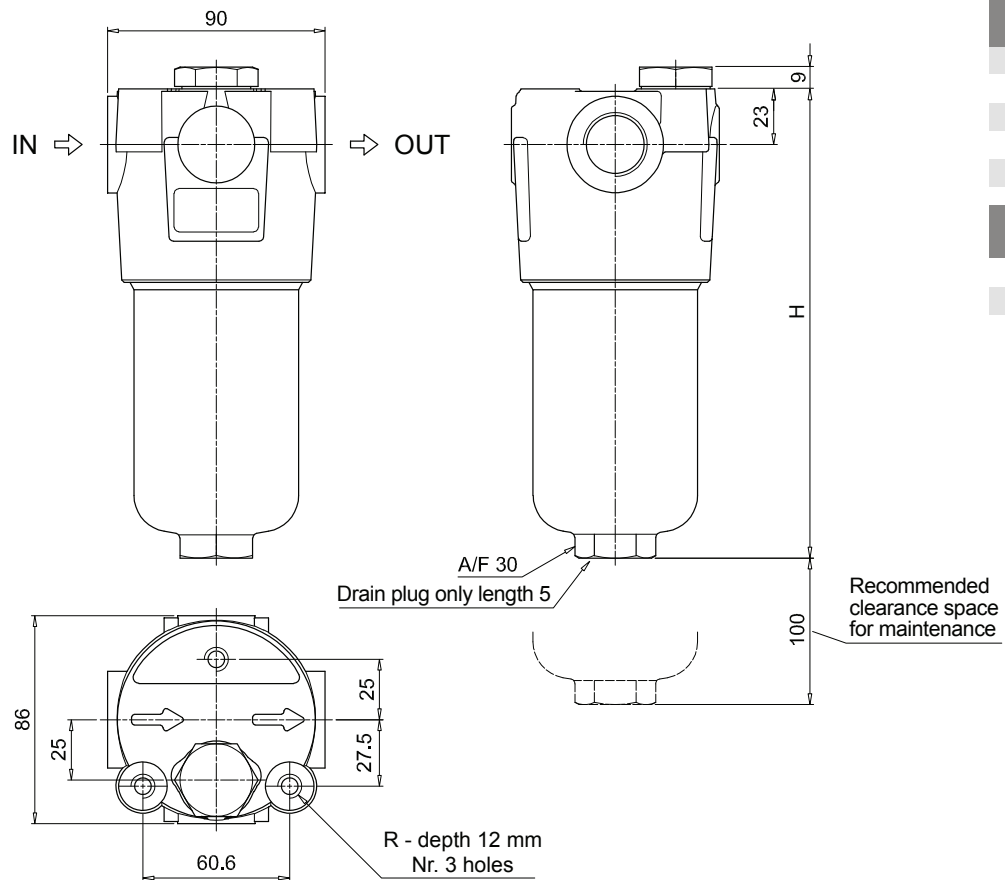

FHA051	
Filter length	H [mm]
1	158
2	195
3	237
4	285
5	407
Connections	R
A-B-C-D	M10
E-F-G-H	3/8" UNC

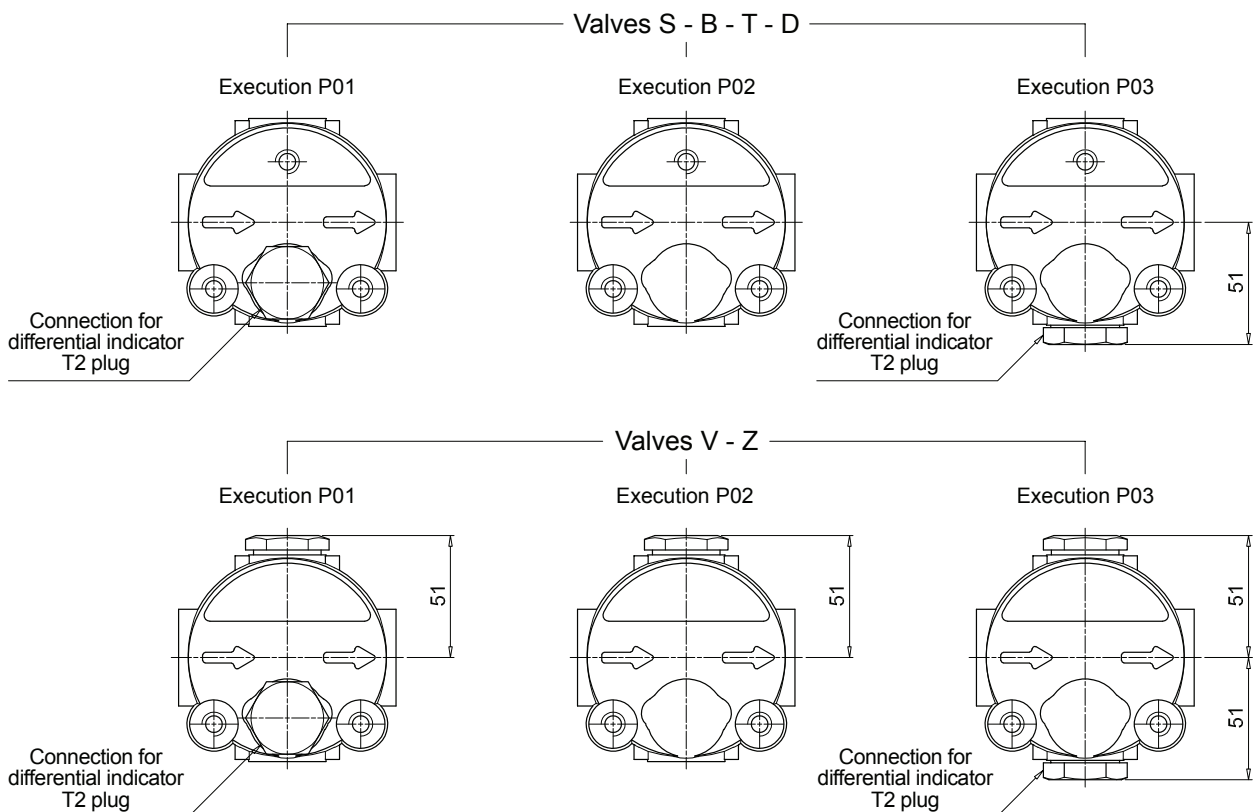

FHA 051 SPARE PARTS

Order number for spare parts

FHA 051

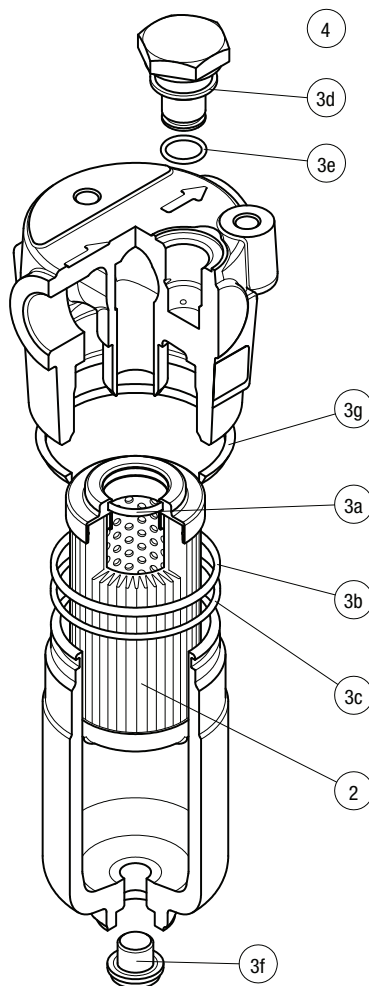

Item:	Q.ty: 1 pc.	Q.ty: 1 pc.		Q.ty: 1 pc.	
Filter series	Filter element	Seal Kit code number		Indicator connection plug	
FHA 051	See order table	NBR	FPM	NBR	FPM
	2	3 (3a ÷ 3g)		4	
		02050288	02050305	T2H	T2V