

Type VMD..20 pressure relief valves

- Direct acting

Technical specifications and diagrams are measured with mineral oil of 46 cSt viscosity at 40°C (104°F) temperature.

	VMD..2001	VMD..2002
Nominal flow	20 l/min (5.3 US gpm)	20 l/min (5.3 US gpm)
Max. pressure	Aluminium body = 210 bar (3050 psi) Steel body = 350 bar (5100 psi)	
Fluid	mineral based oil	
Viscosity	from 10 to 200 cSt	
Max. level of contamination	18/16/13 ISO4406	
Fluid temperature	with NBR seals from -20°C (-4°F) to 80°C (176°F)	
Environmental temp.for working conditions	from -40°C (-40°F) to 100°C (212°F)	
Weight	aluminium	0.30 kg (0.66 lb)
	steel	0.61 kg (1.34 lb)
		0.28 kg (0.62 lb)
		0.59 kg (1.30 lb)

NOTE - For different conditions, please contact Walvoil Sales Dpt.

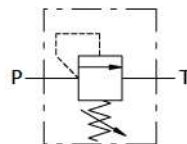

Dimensions

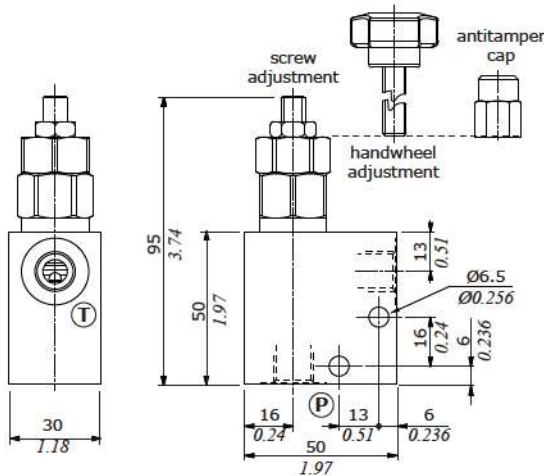

Dimensions are in mm-in

Valve type	All ports
VMD..20 01	G1/4
VMD..20 02	G3/8

Ordering codes and description composition

Port size: **B** 1
 - aluminium
 S = steel

Setting range: **1**

Adjustment option:
 1 = screw type
 2 = handwheel type
 3 = antitamper cap

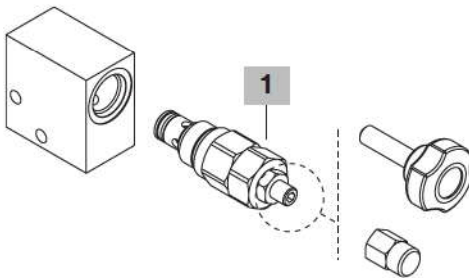

Spring type	Setting range bar (psi)	Std. setting bar (psi)
A	5-60 (72.5-870)	30 (432)
B	50-240 (725-3500)	150 (2200)
C	90-350 (130-5100)	250 (3600)
D	20-130 (290-1900)	70 (1000)

VMD..20 complete valves

TYPE	CODE	DESCRIPTION
Configuration with G1/4 standard thread		
VMD2001B1	1110611100	Aluminium body, setting range from 50 to 240 bar (725-3500 psi), std setting 150 bar @ 5 l/min (2200 psi @ 1.32 US gpm)
VMDS2001B1	1110612100	Steel body, as previous
Configuration with G3/8 standard thread		
VMD2002B1	1110621100	Aluminium body, setting range from 50 to 240 bar (725-3500 psi), std setting 150 bar @ 5 l/min (2200 psi @ 1.32 US gpm)
VMDS2002B1	1110622100	Steel body, as previous

For different configurations and SAE thread please contact our Sales Dpt.

1 Direct acting pressure relief valves

TYPE	CODE	DESCRIPTION
MC08F/0G2B	0MC08002069	Screw adjustment, setting range from 50 to 240 bar (725-3500 psi)

Rating diagrams

