

Dimensions

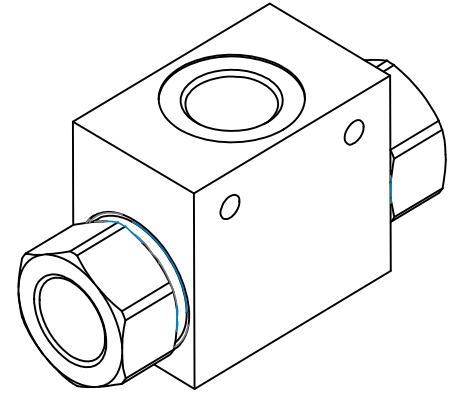

| Size | A   | B  | D    | E<br>BSP | F  | G  | H    | M   | N    | Hex | Weight<br>kg |
|------|-----|----|------|----------|----|----|------|-----|------|-----|--------------|
| 01   | 69  | 36 | 25   | 1/4      | 25 | 35 | 5,5  | 7,5 | 22,5 | 22  | 0,27         |
| 02   | 75  | 45 | 29   | 3/8      | 30 | 45 | 6,5  | 8   | 30   | 27  | 0,46         |
| 03   | 94  | 57 | 36   | 1/2      | 35 | 50 | 5,5  | 9   | 32   | 30  | 0,74         |
| 04   | 100 | 65 | 50   | 3/4      | 50 | 60 | 6,5  | 6,5 | 37,5 | 41  | 1,40         |
| 05   | 126 | 80 | 10,5 | 1        | 50 | 80 | 10,5 | 11  | 54,5 | 46  | 1,87         |

Hydraulic Symbol

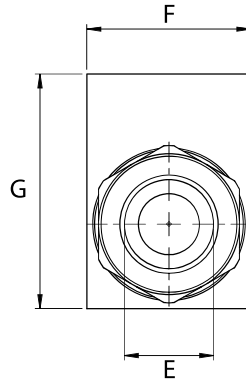
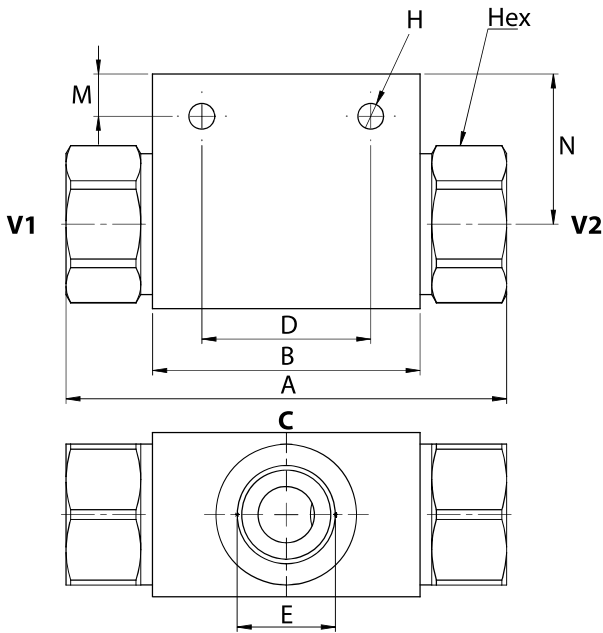
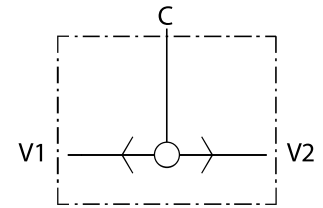

Curves

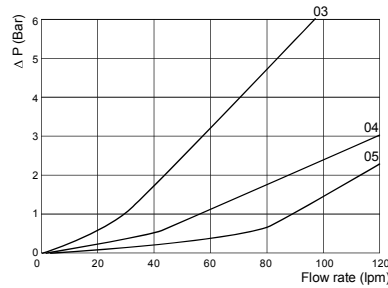
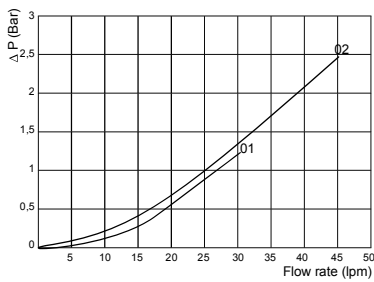

Features

| Size               | 01  | 02  | 03  | 04  | 05  |
|--------------------|-----|-----|-----|-----|-----|
| Max Pressure (bar) | 500 | 500 | 500 | 350 | 300 |
| Max Flow (lpm)     | 35  | 50  | 90  | 140 | 180 |

Materials: Zinc plated steel body.

Ordering Code

SHV --

|    | Size BSP |
|----|----------|
| 01 | 1/4      |
| 02 | 3/8      |
| 03 | 1/2      |
| 04 | 3/4      |
| 05 | 1        |

Ordering Code Example: SHV03 = 1/2 BSP.