

FRI series

Maximum working pressure up to 2 MPa (20 bar) - Flow rate up to 1500 l/min



Description

Technical data

Return filter

Maximum working pressure up to 2 MPa (20 bar)

Flow rate up to 1500 l/min

FRI is a range of return filters for protection of the reservoir against the system contamination.

They could be directly fixed to the reservoir in immersed or semi-immersed position or connected to the lines of the system through the hydraulic fittings.

The filter output must be always immersed into the fluid to avoid aeration or foam generation into the reservoir.

Available features:

- Female threaded connections up to 2 1/2" and flanged connections up to 3 1/2", for a maximum flow rate of 1500 l/min
- Double input connections, to connect several return lines or drains
- Fine filtration rating, to get a good cleanliness level into the reservoir
- Bypass valve, to relieve excessive pressure drop across the filter media
- Visual, electrical and electronic differential clogging indicators

Common applications:

Heavy duty industrial equipment

Filter housing materials

- Filter body
 - Aluminium: FRI 255
 - Anodized Aluminium: FRI 025-040-100-250-630
 - Phosphatized Steel: FRI 850
- Cover
 - Polyamide, GF reinforced: FRI 255
 - Anodized Aluminium: FRI 025-040-100-250-630-850
- Valve: Polyamide, GF reinforced - Steel

Bypass valve

Opening pressure 240 kPa (2.4 bar) ±10%

Δp element type

- Microfibre filter elements - series N: 10 bar
- Fluid flow through the filter element from OUT to IN

Seals

- Standard NBR series A
- Optional FPM series V

Temperature

From -25 °C to +110 °C

Note

FRI filters are provided for vertical mounting



Weights [kg] and volumes [dm³]

Filter series	Weights [kg]		Volumes [dm ³]	
	Length	1	Length	1
FRI 025		1.0		0.28
FRI 040		2.0		0.70
FRI 100		3.8		1.09
FRI 250		6.3		2.60
FRI 255		4.2		3.20
FRI 630		13.8		7.05
FRI 850		48.0		21.50

Filter housings Δp pressure drop

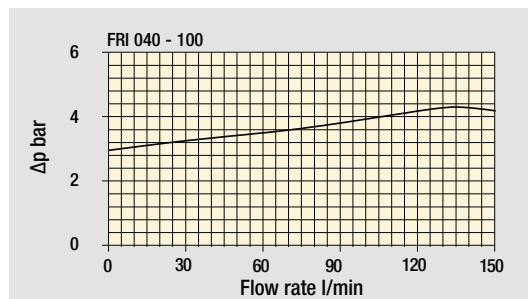
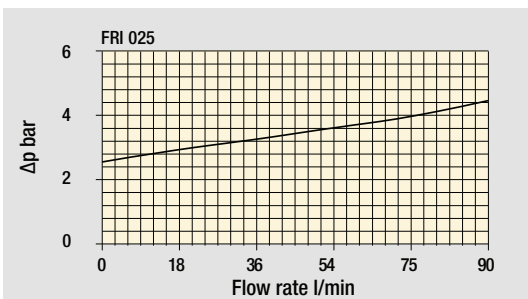
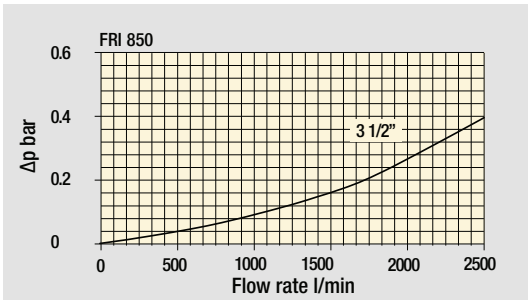
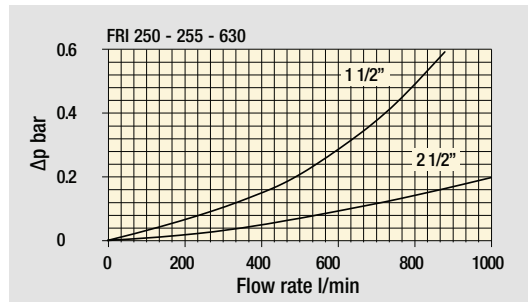
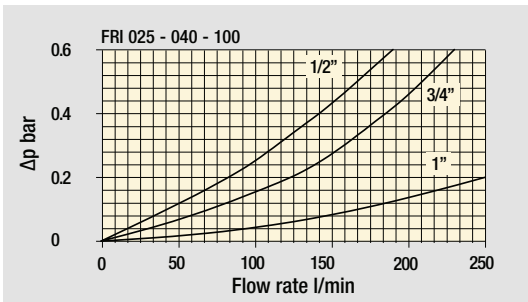

Bypass valve pressure drop

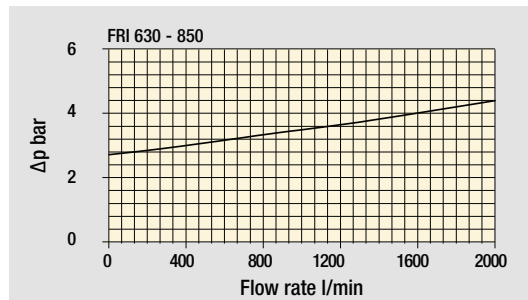
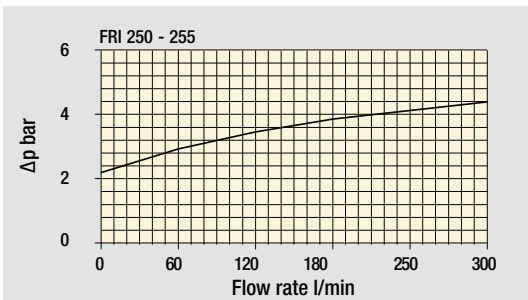

The curves are plotted using mineral oil with density of 0.86 kg/dm³ in compliance with ISO 3968.
 Δp varies proportionally with density.

FRI GENERAL INFORMATION

Flow rates [l/min]

Filter series	Length	Filter element design - N Series							
		A03	A06	A10	A16	A25	M25 M60 M90	P10	P25
FRI 025	1	6	10	17	19	43	122	43	47
FRI 040	1	19	23	43	45	94	155	94	102
FRI 100	1	32	34	89	92	187	260	187	206
FRI 250	1	144	179	271	300	448	645	448	490
FRI 255	1	144	179	271	300	448	645	448	490
FRI 630	1	242	279	508	577	834	1446	834	911
FRI 850	1	440	541	971	1143	1705	2528	1705	1880

Maximum flow rate for a complete return filter with a pressure drop $\Delta p = 0.5$ bar.

The reference fluid has a kinematic viscosity of 30 mm²/s (cSt) and a density of 0.86 kg/dm³.

For different pressure drop or fluid viscosity we recommend to use our selection software available on www.mpfiltri.com.

Please, contact our Sales Department for further additional information.

Hydraulic symbols

Filter series	Style 1 connection + Diff. indic.	Style 2 connections + Diff. indic.
FRI 025		•
FRI 040		•
FRI 100		•
FRI 250		•
FRI 255	•	
FRI 630		•
FRI 850	•	

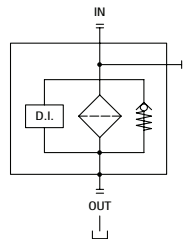
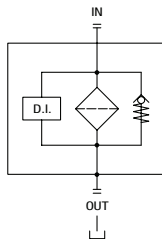

Designation & Ordering code

COMPLETE FILTER

Series and size	Configuration example 1: FRI025 B A G1 A25 N P01						
FRI025	Configuration example 2: FRI040 S W G2 M25 N P01						
FRI040							
Bypass valve							
B With bypass							
S Without bypass							
Seals and treatments	Filtration rating						
A NBR	Axx	Mxx	Pxx				
V FPM	•	•	•				
W NBR head anodized	•	•					
Z FPM head anodized	•	•					
	filter element compatible with fluids HFA-HFB-HFC						
Connections for FRI025	Connections for FRI040						
G1 G 1/2"	G 3/4"						
G2 1/2" NPT	3/4" NPT						
G3 SAE 8 - 3/4" - 16 UNF	SAE 12 - 1 1/16" - 12 UN						
Filtration rating (filter media)							
A03 Inorganic microfiber 3 µm	M25 Wire mesh 25 µm						
A06 Inorganic microfiber 6 µm	M60 Wire mesh 60 µm						
A10 Inorganic microfiber 10 µm	M90 Wire mesh 90 µm						
A16 Inorganic microfiber 16 µm	P10 Resin impregnated paper 10 µm						
A25 Inorganic microfiber 25 µm	P25 Resin impregnated paper 25 µm						
				Element Δp	Execution		
				N 10 bar	P01 MP Filtri standard		
					Pxx Customized		

FILTER ELEMENT

Element series and size	Configuration example 1: CU025 A25 N P01			
CU025	Configuration example 2: CU040 M25 W P01			
CU040				
Filtration rating (filter media)				
A03 Inorganic microfiber 3 µm	M25 Wire mesh 25 µm			
A06 Inorganic microfiber 6 µm	M60 Wire mesh 60 µm			
A10 Inorganic microfiber 10 µm	M90 Wire mesh 90 µm			
A16 Inorganic microfiber 16 µm	P10 Resin impregnated paper 10 µm			
A25 Inorganic microfiber 25 µm	P25 Resin impregnated paper 25 µm			
Seals and treatments	Filtration rating			
N NBR	Axx	Mxx	Pxx	
V FPM	•	•	•	
W NBR	•	•		
Z FPM	•	•		
	filter element compatible with fluids HFA-HFB-HFC			
				Execution
				P01 MP Filtri standard
				Pxx Customized

ACCESSORIES

Indicators	page		page
DEA Electrical differential indicator	242	DTA Electronic differential indicator	245
DEM Electrical differential indicator	242-243	DVA Visual differential indicator	245
DLA Electrical / visual differential indicator	243-244	DVM Visual differential indicator	245
DLE Electrical / visual differential indicator	244		
Additional features	page		
T2 Plug	246		

FRI025

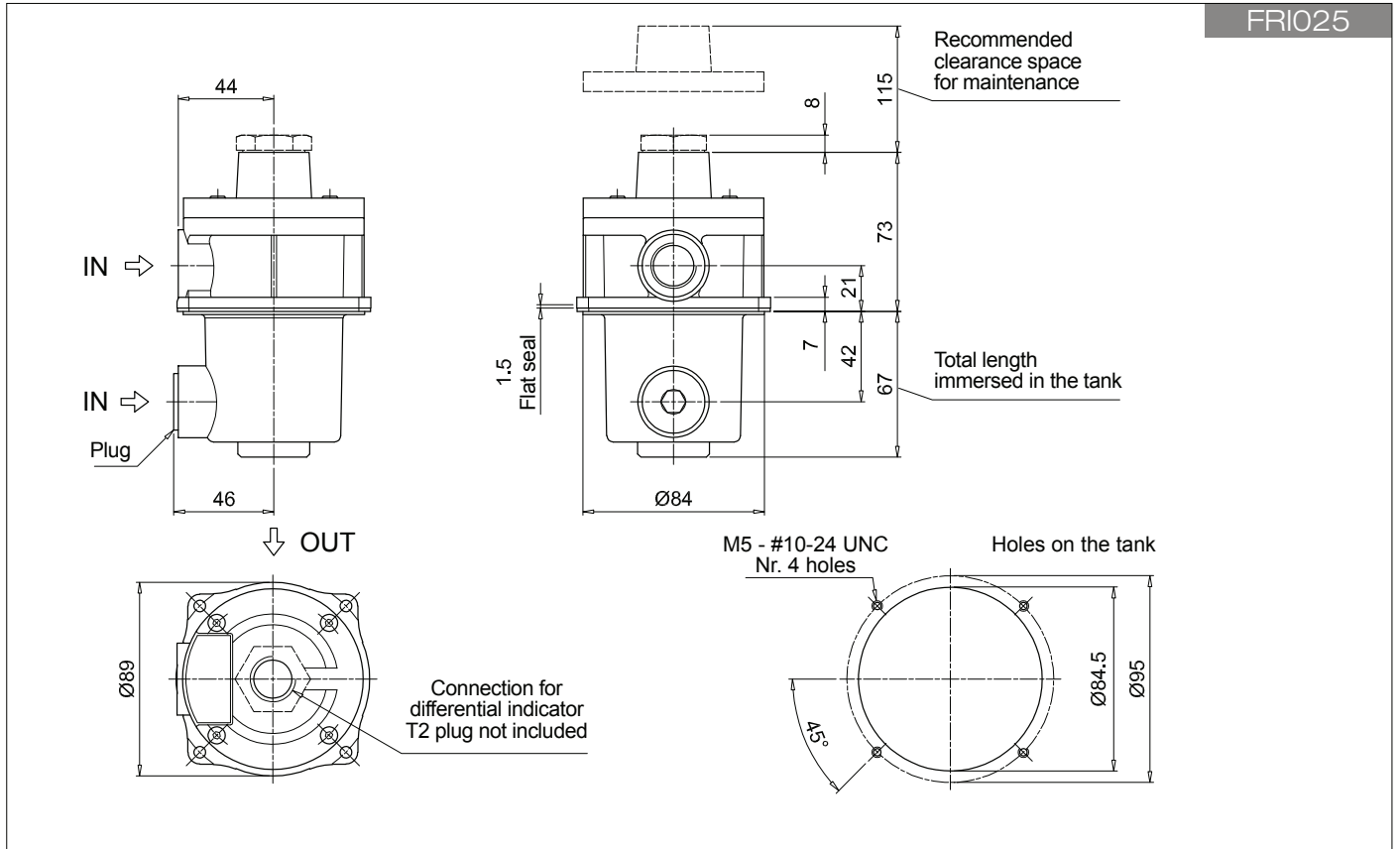

FRI040

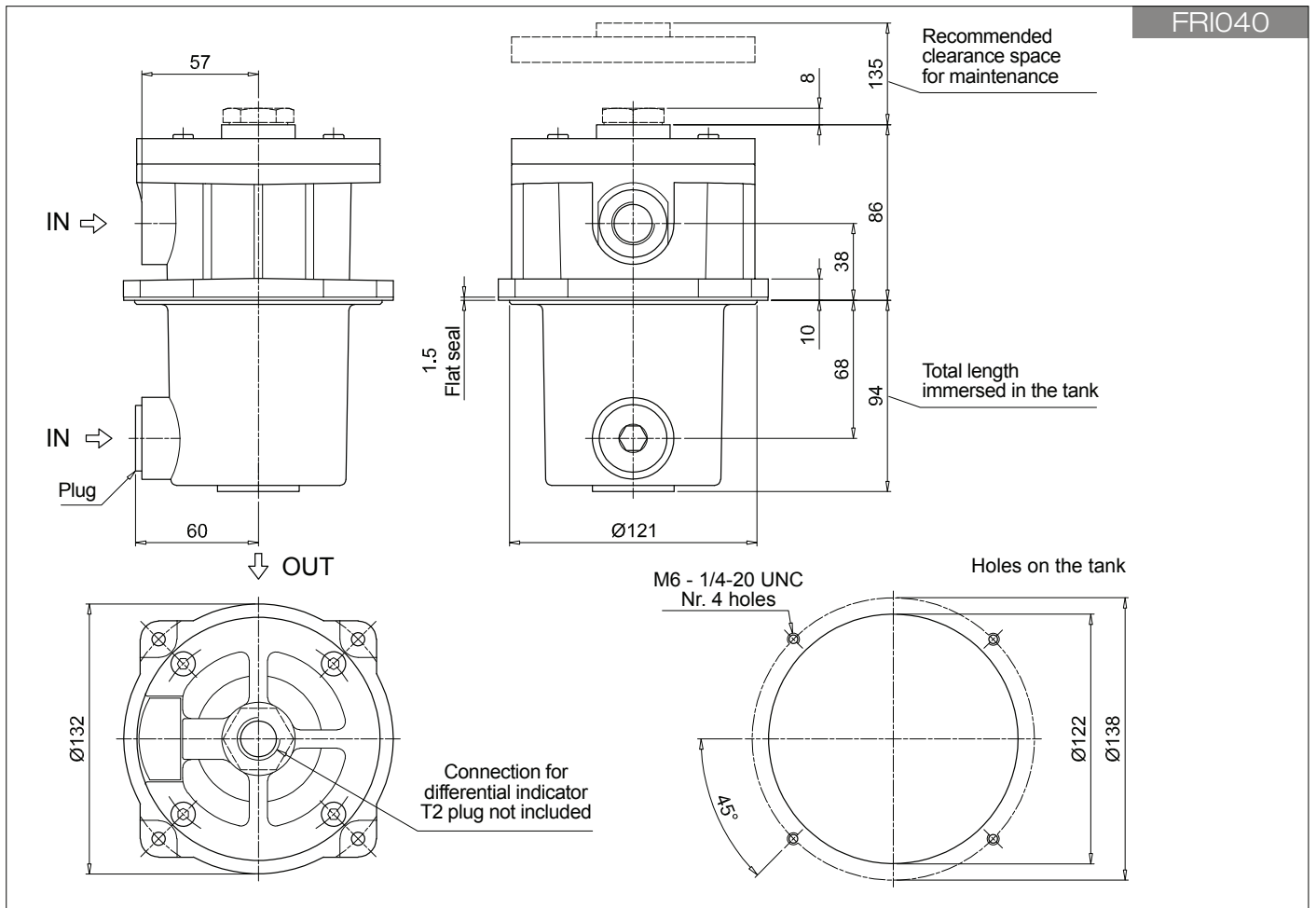

FRI SPARE PARTS

Order number for spare parts

FRI 025 - 040

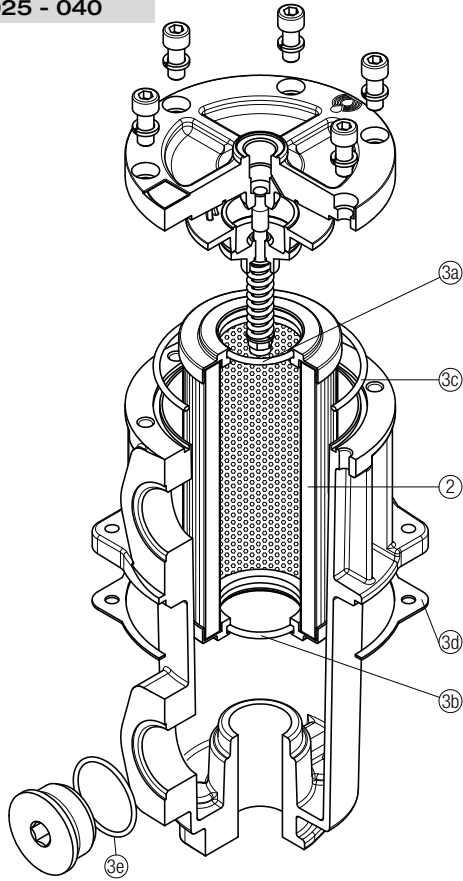

Item:	Q.ty: 1 pc.	Q.ty: 1 pc.	
	2	3 (3a ÷ 3e)	
Filter series	Filter element	Seal Kit code number	
		NBR	FPM
FRI 025	See order table	02050213	02050220
FRI 040		02050214	02050221

FRI 100 - 250 - 630

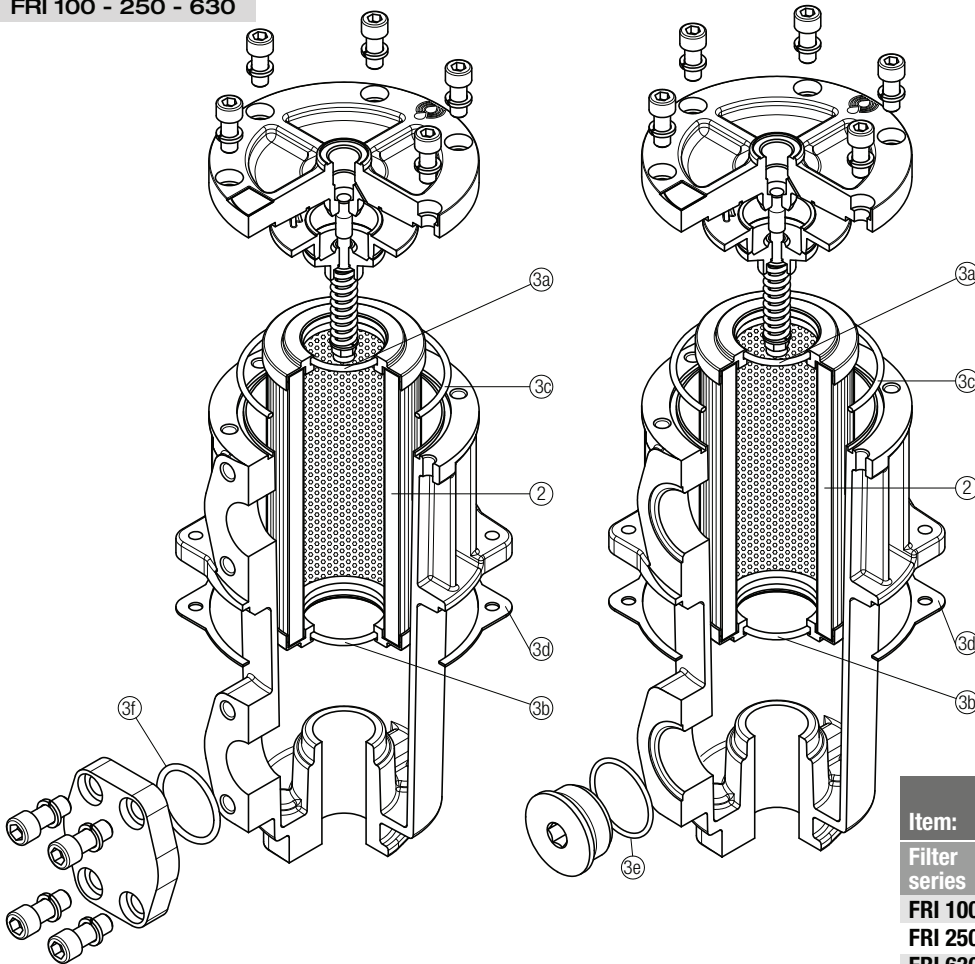

Item:	Q.ty: 1 pc.	Q.ty: 1 pc.	
	2	3 (3a ÷ 3f)	
Filter series	Filter element	Seal Kit code number	
		NBR	FPM
FRI 100	See order table	02050215	02050222
FRI 250		02050216	02050223
FRI 630		02050217	02050224