

POWER TRANSMISSION PRODUCTS

BELL-HOUSING



PASSION TO PERFORM



Bell-Housing are used as connecting elements between IEC motors and wide range of hydraulic pumps available on the international market.

Made in Aluminium die cast, they cover a range from IEC motor size 63 to IEC motor size 355.

They are available in six different styles:

- LMG series for gear pumps
- LMC series monobloc bell-housing
- LDC series made in 2 pcs fixed by screws
- LMS series able to reduce the noise
- LDS series made in 2 pcs fixed by screws
- MULTI-COMPONENTS made by 3 pcs for IEC motors from sizes 132 up to size 225,
made by 2 pcs for IEC motors from size 250 up to size 355

For the Bell-Housing selection you require please see our on-line software at www.mpfiltri.com.

BELL-HOUSING & COUPLING SIZING

A GUIDE TO SELECT THE CORRECT BELL-HOUSING AND DRIVE COUPLING

DATA REQUIRED

- Electric motor power/motor size
- Manufacturer and pump type

TO VERIFY:

- 1 - Pump and motor shaft dimensions (see electric motor data sheet)
- 2 - Shaft and flange pump (see pump data sheet)

Example:

- Electric motor 2.2 kW - size 100-112
- Atos pump code PFE31 - Shaft 1

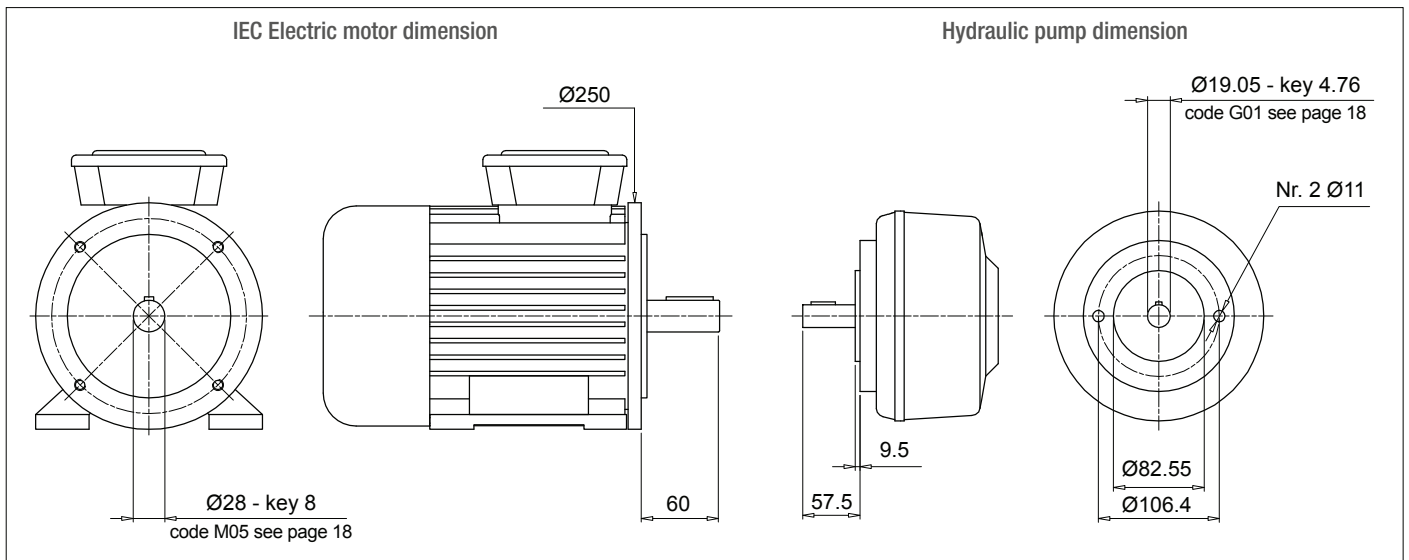

Bell-Housing's length calculation

- $H = 60 + 18 + 57.5 = 135.5$ mm (18 = Sp spider - see page 31)
- Choose type of bell-housing (LMC - LMS):
For monobloc bell-housing LMC/LDC series see pages 71 ÷ 77
For Low noise bell-housing LMS/LDS series see pages 79 ÷ 85
For Multi-components 2-3 bell housing series see pages 87 ÷ 107

Note:

The length of bell-housing must be \geq than the length calculated (135.5 mm)

Case A

Solution with monobloc bell-housing series **LMC/LDC**

Pages 71 ÷ 77 for IEC Electric motor size 100-112 - LMC250

LMC 250 bell-housing with height ≥ 135.5 - LMC250AFSQ

The bell-housing code must be completed with pump drilling code (see pages 56-57).

For the specific case:

Spigot hole 82.55 - PCD 106.4 - Nr.2 holes M10 : Drilling code 060

Definitive bell-housing code **LMC250AFSQ060**

Case B

Solution with low noise bell-housing series **LMS/LDS**

Pages 79 ÷ 85 for IEC Electric motor size 100-112 - LMS250

LMS 250 bell-housing with height ≥ 135.5 - LMS250AFSA

The bell-housing code must be completed with pump drilling code (see pages 56-57).

For the specific case:

Spigot hole 82.55 - PCD 106.4 - Nr.2 holes M10 : Drilling code 060

Definitive bell-housing code **LMS250AFSA060**

Coupling selection

Motor half-coupling (see page 26)

For IEC Electric motor size 100/112, the half-coupling is **SGEA21M05060FG**

Spider (see page 31)

For SGEA21, EGE2 - EGE2RR

(choose spider material on the base of the application, oil, temperature and cycle machine, etc.)

Pump half-coupling

Choose the drilling code - see pages 18-19 for shaft 19.05 - key 4.76 - code: **G01**

Pump half-coupling length = BH length - THK Spider - THK Spigot

$$\text{LMC} = 138 \text{ mm} - 60 - 18 - 9.5 = 50.5 \text{ mm}$$

$$\text{LMS} = 148 \text{ mm} - 60 - 18 - 9.5 = 60.5 \text{ mm}$$

LMC - Choose the half-coupling's length at page 26 \leq 50.5 mm.

LMS - Choose the half-coupling's length at page 26 \leq 60.5 mm.

LMC - Available length for SGEA21 = 50 mm

LMS - Available length for SGEA21 = 60 mm

Half coupling for LMC: **SGEA21G01050FG**

Half coupling for LMS: **SGEA21G01050FG**

SOFTWARE FOR AUTOMATIC CALCULATION

available on the web site www.mpfiltri.com

PRODUCT SELECTION | POWER TRANSMISSION SOFTWARE | FILTER SIZING SOFTWARE

SELECTION FROM PUMP MANUFACTURER | SELECTION FROM SHAFT / FLANGE DATA | SELECTION WITH PUMP DATA ENTRY | SELECTION FROM KIT CODE

Manufacturer:

Pump type:

Pump code:

ELECTRIC MOTOR DATA

N. Poles: L: D: Fig: Ch:

Motor frame:

Size:

Power Kw:

Power Hp:

Note: for multi pumps we recommend to use a specific support on the base of the pump's dimensions and weight.

Step 1 Select "POWER TRANSMISSION SOFTWARE" after login



Step 2 Choose Manufacturer: select "Pump type" and "Pump code"



Step 3 Choose N Poles of "Electric motors": select "Motor frame" and "Size"



Step 4 Choose the insert and eventual Bell-Housings option and accessories for assembly; click on "CALCULATE"

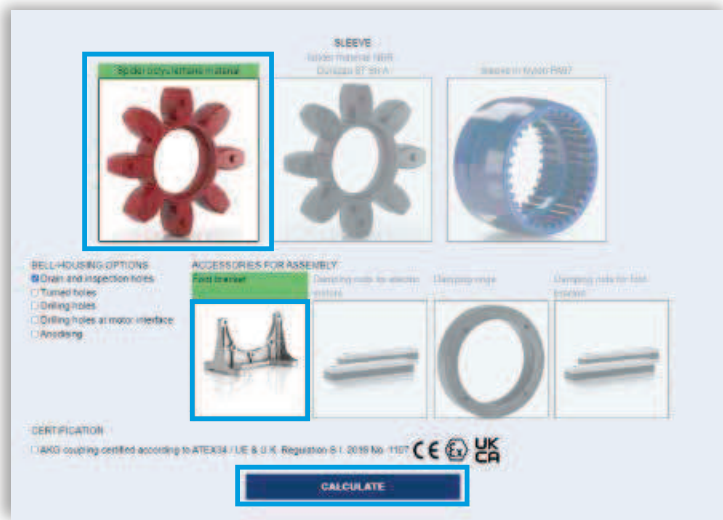

Step 5 Select the option requested and download the report.



Step 6 Download PDF

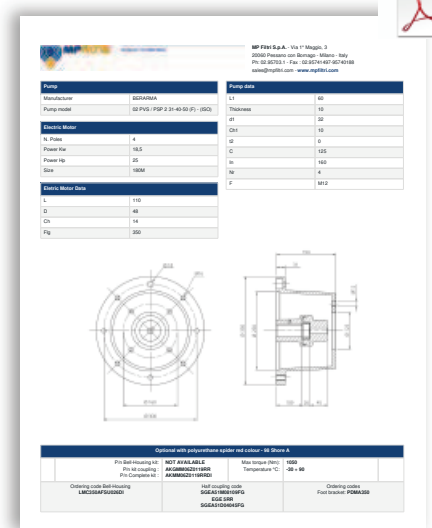

You can't find the pump on the system?

NEW FEATURE!!

Insert pump's dimension on the section "SELECTION WITH PUMP DATA ENTRY" and follow the instructions to achieve the couplings components code

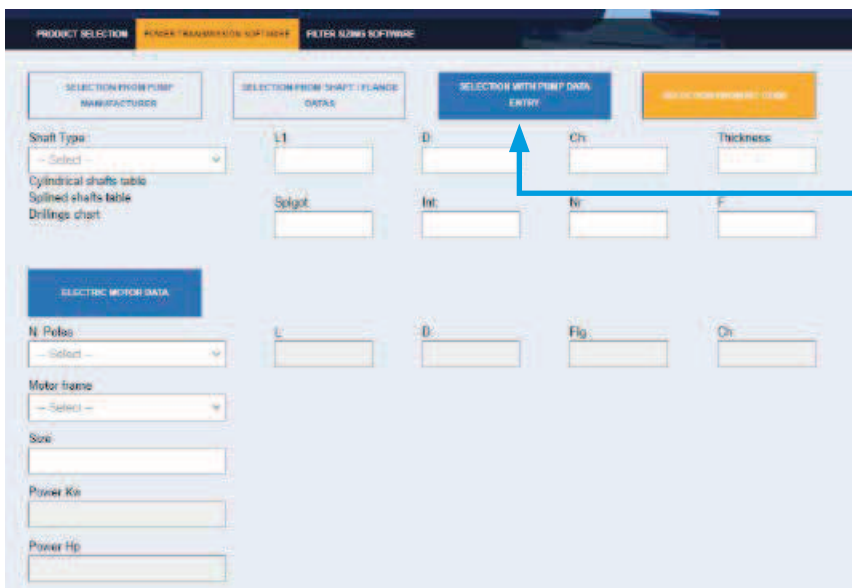

Noise is a particularly pervasive problem so much so that there have been statutory regulations in place now for some years, designed to limit harmful occupational exposure.

Many of the machines used in industry today are equipped with oil-hydraulic systems, which happen to be a major source of noise.

① THEORY AND DEFINITION OF NOISE

From a health and hygiene standpoint, noise can be defined as an unpleasant and undesirable sound, or an unpleasant and annoying or intolerable auditory sensation (noise being any sound phenomena that may be accompanied by sensations of disturbance and pain). By definition, acoustic phenomena are oscillatory in character, propagated in a flexible medium and causing pressure variations at the points, and the areas adjacent to those points, through which they pass.

② SOUND

Technically considered, certain elements must be present simultaneously for acoustic phenomena to occur:

- Sound source
- Transmission medium
- Receiver

The electric motor and the pump, together with the drive coupling, are the SOURCE OF THE NOISE. The Bell-housing is the noise transmission MEDIUM. Depending on whether the monobloc bell-housing is a rigid or low noise type, there will be variations in the flexible properties of the transmission medium. The acoustic phenomena are dissimilar in the two cases, given the differences in pressure variation and particle displacement.

MOTOR AND PUMP UNIT

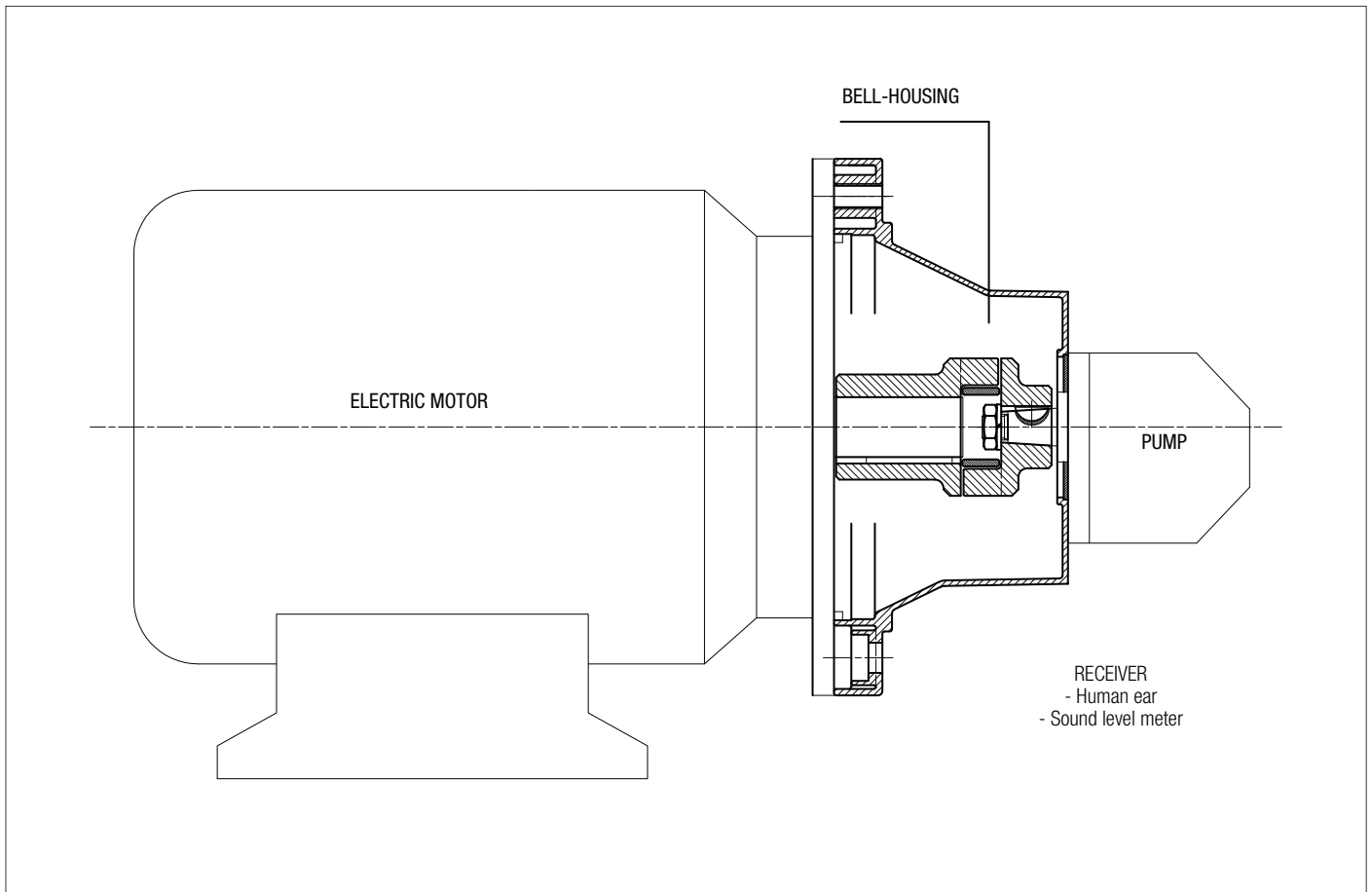

Low noise bell-housing will help to attenuate the transmission of vibrations and the emission of noise generated by the system. Self-evidently, however, the mere adoption of a low noise bell-housing will achieve little unless the motor and pump are correctly installed on the machine or on the tank of the hydraulic power unit.

Should be followed in order to achieve best possible results and correct installation:

1 MOTOR AND PUMP UNIT MOUNTED HORIZONTALLY ON OIL TANK LID

- The suction pipe attached to the pump must be rigid and fitted using a resilient bulkhead flange of the FTA series, which helps to cushion the vibrations propagated between the pipe and the tank lid. If pipes need to be bent, the radius of curvature must be at least 3 times the pipe diameter. Do not use elbow fittings, as these will significantly increase pressure losses.
- The pressure pipeline of the pump must be flexible and long enough to include bends with the minimum radius of curvature recommended by the manufacturer for the specified operating pressure.
- The return pipeline running from the service to the filter must be flexible. Where oil is returned directly to the tank of the hydraulic power unit through a rigid pipe, it is advisable to use a resilient bulkhead flange of the FTR series, which helps to cushion the vibrations propagated between the pipe and the tank lid.
- Anti-vibration devices (resilient mounts or damping rods) must be located under the feet of the electric motor or the PDM foot brackets, depending on the mounting position of the motor.
- The lids of hydraulic oil tanks must be sturdy enough to support the load they carry.

2 MOTOR AND PUMP UNIT MOUNTED HORIZONTALLY ON MACHINE

- As a matter of good practice, the oil tank and motor-pump unit should be mounted on a single supporting frame of strength sufficient to support the load.
- If the hydraulic system is fitted with a side-mounted filter, the suction pipeline to the pump must be flexible and long enough to include bends with the minimum radius of curvature recommended by the manufacturer.
- If the suction filter is not side mounted, the pipeline should be rigid and installed in conjunction with a compensating coupling.
- The pressure pipeline of the pump must be flexible, and long enough to include bends with the minimum radius of curvature recommended by the manufacturer for the specified operating pressure.
- The return pipeline running from the service to the filter must be flexible. Where oil is returned directly to the tank of the hydraulic power unit through a rigid pipe, it is advisable to use a resilient bulkhead flange of the FTR series, which helps to cushion the vibrations propagated between the pipe and the tank lid.
- Anti-vibration devices (resilient mounts or damping rods) must be located under the feet of the electric motor or the PDM foot brackets, depending on the mounting position of the motor.

FINAL CONSIDERATION

For best results, in any event, the motor-and-pump unit should be incorporated into the hydraulic system in such a way that no one component is rigidly associated with another, resulting in the propagation of vibration, and consequently noise.

RECOMMENDED TIGHTENING TORQUES FOR MOTOR/PUMP FIXING ON THE BELL-HOUSING

M6	10 N·m	M16	205 N·m
M8	15 N·m	M18	280 N·m
M10	50 N·m	M20	400 N·m
M12	84 N·m	M22	530 N·m
M14	135 N·m	M24	690 N·m

Note: The above guidelines are indicative only and subordinate to the solutions adopted ultimately by design engineers.