

Analog electronic E-MI-AC drivers

DIN 43650 plug-in format, for proportional valves without transducer

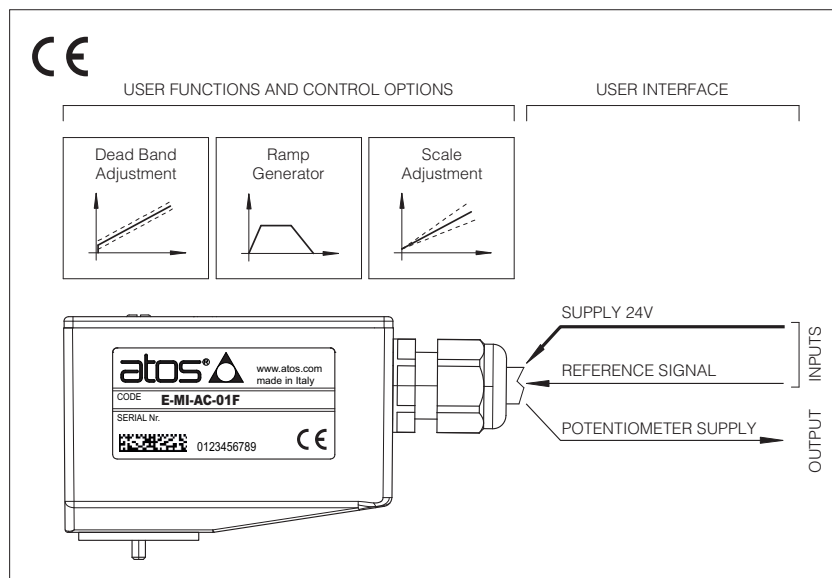

E-MI-AC

Analog drivers control the current to the solenoid of Atos proportional valves without pressure or LVDT position transducer, regulating the spool position, the flow or the pressure according to the electronic reference signal.

Features:

- bias and scale regulations by potentiometers
- symmetrical (standard) or dissymmetrical (/RR option) rising and falling ramp generator
- factory pre-set
- alluminium box with IP65 protection degree
- electronic filters on input and output lines
- CE mark according to EMC directive

Applications:

Pressure, flow, position open or closed-loop systems, according to the block diagram [2](#).

1 MODEL CODE

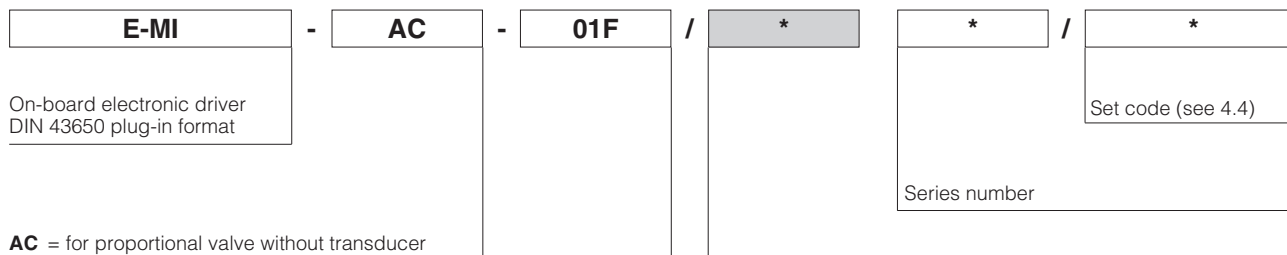

01F = for single solenoid proportional valve

Options:

- = standard symmetrical ramps
- RR** = adjustable dissymmetrical ramps, adjustable dither, suitable also for current signal $0 \div 20$ mA
- 7** = pre arranged for double solenoid valves control

2 BLOCK DIAGRAM

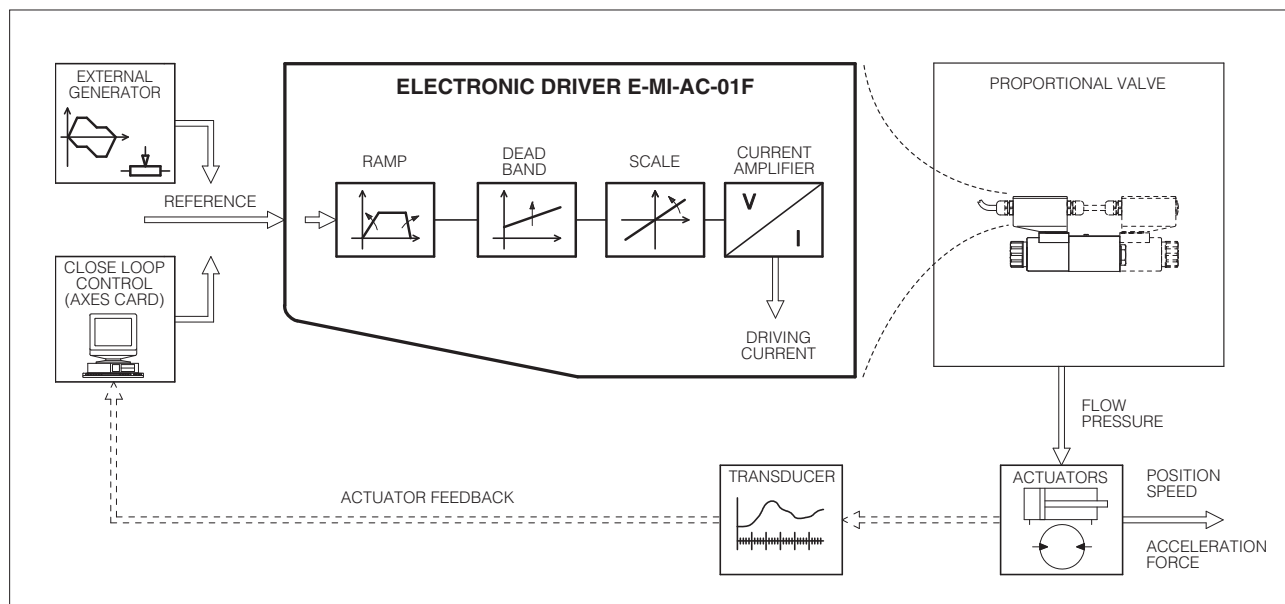

3 MAIN CHARACTERISTICS

Power supply (see 4.1)	Nominal: +24 Vdc Rectified and filtered: $V_{RMS} = 21 \div 33 V_{MAX}$ (ripple max 10 % VPP) Nominal: +12 Vdc Rectified and filtered: $V_{RMS} = 10 \div 14 V_{MAX}$ (ripple max 10 % VPP)
Max power consumption	50 W
Current supplied to solenoid	$I_{MAX} = 2,7$ A type PWM square wave (with solenoid type ZO(R)-A with resistance 3,2 Ω)
Nominal reference signal (factory preset)	0 \div 10 Vdc
Reference signal variation range (scale adjustment)	0 \div 10 Vdc (0 \div 5 VMIN) – (0 \div 20 mA for current signal)
Input signal impedance	Voltage signal $R_i > 50$ k Ω – ($R_i = 250$ Ω for current signal)
Potentiometers supply	+5 V / 10 mA at contact 3
Ramp time	10 sec. max (0 \div 10 V of reference signal)
Format	Box equipped with DIN 43650-IP65 plug; VDE 0110 wired on solenoid
Operating temperature	0 \div +50 $^{\circ}C$ (storage -20 \div +70 $^{\circ}C$)
Mass	190 g
Additional characteristics	Outputs to solenoids protected against accidental short circuits
Compliance	CE according to EMC directive 2014/30/EU (Immunity: EN 61000-6-2; Emission: EN 61000-6-4) RoHS Directive 2011/65/EU as last update by 2015/863/EU REACH Regulation (EC) n $^{\circ}$ 1907/2006
Connections	7 contacts – terminal strip
Recommended wiring cable	LiYCY shielded cables: 0,5 mm 2 up to 1,0 mm 2 (20 AWG - 18 AWG)

4 GENERAL SPECIFICATIONS

4.1 Power supply and wiring

The power supply must be appropriately stabilized or rectified and filtered. If the power supply is generated by a single phase rectifier use a 10000 $\mu F/40V$ capacitor; if pulse voltage is generated by a three phase rectifier, connect a 4700 μF capacitor (see [11]).

Connect the reference signal to the main electronic control by means of shielded and twisted cables. Pay attention: the negative and the positive poles must not be exchanged each other. Shield the wirings to avoid electromagnetic noise (EMC), connecting the shield to noiseless earth (TE), see [13]. It is suitable to keep the driver and its cables far from any electromagnetic radiation source (like cables where high currents flow, electric motors, transformers, relays, solenoids, portable radio-transmitter, etc.).

The 12 Vdc electric voltage supply is allowed only after evaluation of the performances required from the proportional valves, and however after check with our technical office.

According to power supply value, a safety fuse is required in series to each driver:

- +24 Vdc - 2,5 A time lag fuse
- +12 Vdc - 4 A time lag fuse

4.2 Reference signal, see [5].

The electronic driver is designed to receive a voltage reference signal according to the following options:

- potentiometers mounted externally and wired according to the application diagrams.
- external reference signals generated by PLC, see [11].
- voltage from 0 to 10V
- current from 0 to 20 mA (only with /RR option).

4.3 Monitor signal

This voltage output signal allows to measure the current supplied to the coil, read by a voltmeter between the test point M and pin 2 (see [9]).

Reading scale is 1 mV = 10 mA (eg.: if the voltage signal is 70 mV, coil current is 700 mA). To visualize the signals use voltmeters with impedance >10 K Ω .

4.4 Set code

Basic calibration of the electronic driver is factory pre-set, according to the proportional valve it has to be coupled with. These pre-calibrations are identified by a standard number in the model code as follows:

- | | |
|---------------------|------------------------|
| 1 = RZGO (KZGO) | 2 = RZMO, AG*ZO, LI*ZO |
| 3 = DHZO, DKZOR | 4 = DPZO-A*5 |
| 6 = QV*ZO(R), LEQZO | 8 = DHZE, DKZE |

4.5 Calibrations available to the user, see [7], [8], [9], [11].

Scale

The relation between driving current and reference signal can be regulated with the Scale adjustment.

Bias (dead band)

Regulation of dead band adjusts the hydraulic zero of the valve (starting position adjustment) to the corresponding electrical zero. The electronic card is factory pre-set for the valve it is coupled with, according to the set code (see section 4.4). An output current is obtained when the input voltage is 100 mV or greater.

Ramps see [7], [9].

The internal ramp generator circuit converts a step input signal into a slowly increasing output signal (solenoid current).

The rise/fall time of the current is set via internal potentiometer P1 up to a max. time of 10 sec. for 0-10V of reference signal. The /RR option provides dissymmetrical ramps, ramp up is set via P1 potentiometer and ramp down is set via P2.

Dither

With the /RR option the dither frequency adjust is allowed from 100 Hz to 500 Hz.

5 EXTERNAL REFERENCE SIGNALS

EXTERNAL GENERATOR VOLTAGE SIGNAL

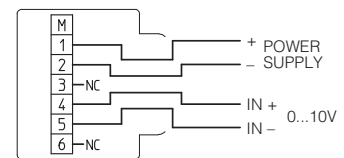

EXTERNAL POTENTIOMETER CONNECTION POTENTIOMETER

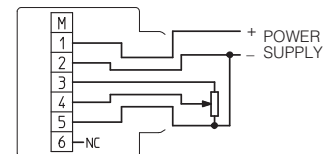

EXTERNAL GENERATOR CURRENT SIGNAL (/RR OPTION)

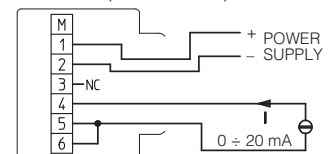

CONNECTION FOR TWO SOLENOIDS PROPORTIONAL VALVE (/7 OPTION, necessary two /7 drivers)

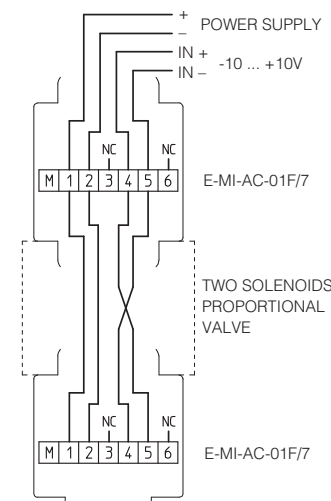

6 INSTALLATION AND START-UP

It is advisable to perform calibration procedures in the order given below:

6.1 Warning

- Never insert or remove the driver while the electronic system is powered on.
- Refer to [9] to identify components mentioned in calibration procedures.
- The E-MI-AC electronic drivers are designed to work in open loop system, where the coupled proportional valve is not required to work at its limits.

6.2 Start-up

Factory pre-set adjustments might not meet the requirements desired for the specific application. Performances can be optimized by on-site re-adjustments of Bias, Scale and Ramps potentiometers, in sequence.

- Remove the cover and connect the electronic driver according to the desired connection diagram, see [5].

For double solenoid valves two electronic drivers type E-MI-AC-01F/7 must be used connected as shown in [5].

Start-up instructions are the same for each driver.

On the first driver two cable clamps must be mounted, one for the external wirings and one to give power and signal to the second driver which is equipped with one cable clamp and one blind plug.

A differential voltage signal $-10\text{ V} \div +10\text{ V}$ must be supplied to the first driver.

Note that the first driver will work with signal from 0 to 10V while the second driver will work with signal from 0 to -10 V.

- The current supplied to the coil can be measured by a voltmeter connected between pins M and 2 of the screw terminal. The reading range will be: $I[\text{mA}] = 10 \times V[\text{mV}]$ (for example reading 70 mV the current in the coil will be 700 mA).

Bias adjustment (dead band compensation) see [8], [9].

- Supply electrical power to the driver; supply a reference signal voltage = 0,1 VDC. Gradually turn the P4 bias potentiometer until a movement of the controlled actuator is obtained.
- Turn in the opposite direction until the actuator is stopped.

Scale adjustment, see [8], [9].

Supply max. current reference signal; check if the current in the coil reaches the max. value desired, turning P3 clockwise (see the regulation curve of the employed valve used).

Ramps see [7], [9].

Turning the ramp potentiometer clockwise, acceleration and deceleration time can be increased to obtain the optimization of the complete system.

7 RAMPS

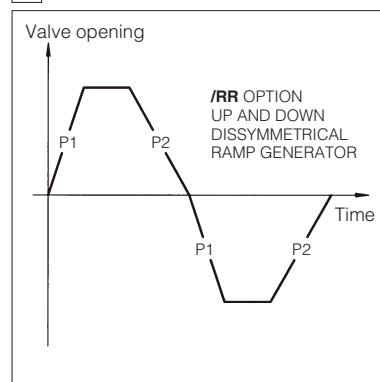

8 BIAS AND SCALE

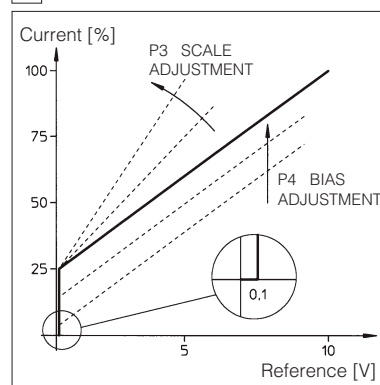

9 REGULATIONS LAYOUT

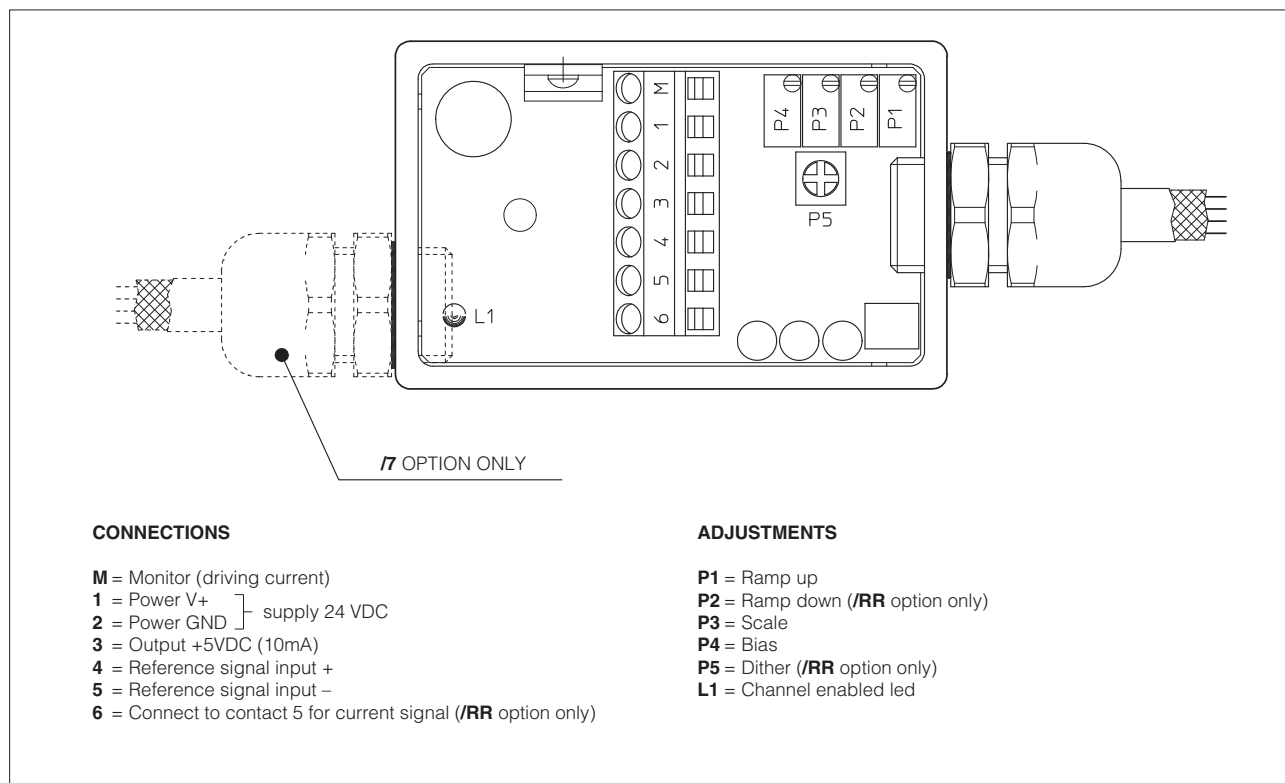

10 IMPORTANT INSTRUCTIONS

ELETTROMAGNETIC COMPATIBILITY

Atos electronic drivers and proportional valves are designed according to the 2014/30/UE Directive (Electromagnetic Compatibility) and according to EN 50081-2 (Emission) and EN 50082-2 (Immunity) standards. The electromagnetic compatibility of electronic drivers is valid only for wirings realized according to the typical electric connections shown in this technical table.

The device must be verified on the machine because the magnetic field may be different from the test conditions.

SAFETY

The electrical signals (for example reference signals, feedback and enable signal) of electronic drivers must not be used to realize safety conditions of the machine. This is in accordance with the provisions of European directives (Safety requirements of fluid technology systems and components-hydraulics, EN 982). Special attention must be paid to switch-on/switch-off of electronic drivers because they could produce uncontrolled movements of actuators operated by the proportional valves.

11 WIRING BLOCK DIAGRAM

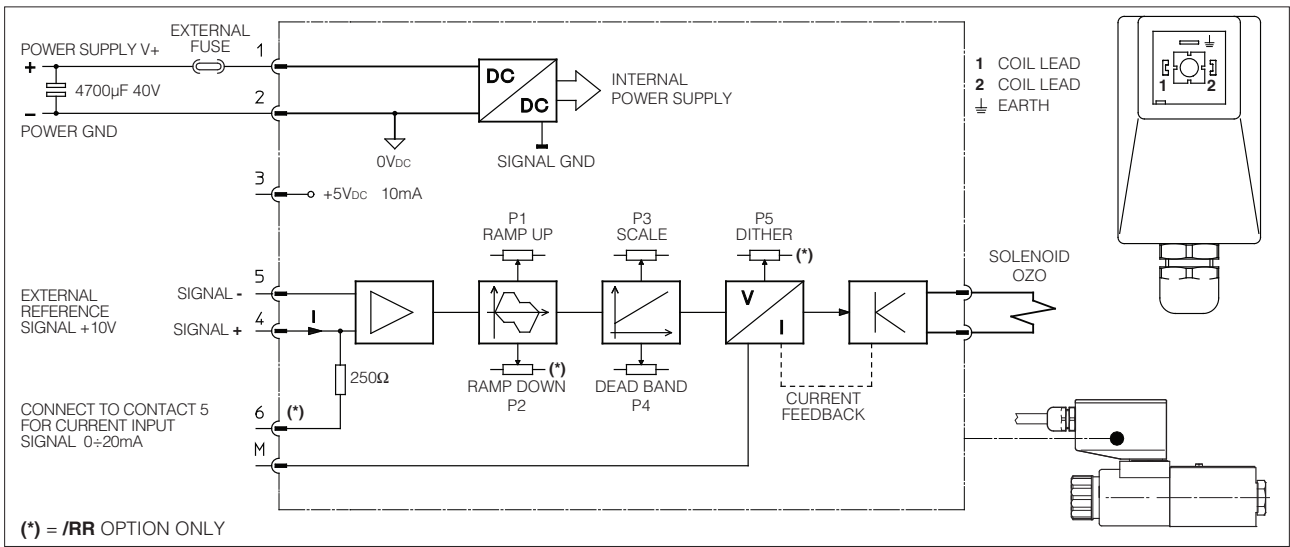

12 OVERALL DIMENSIONS [mm]

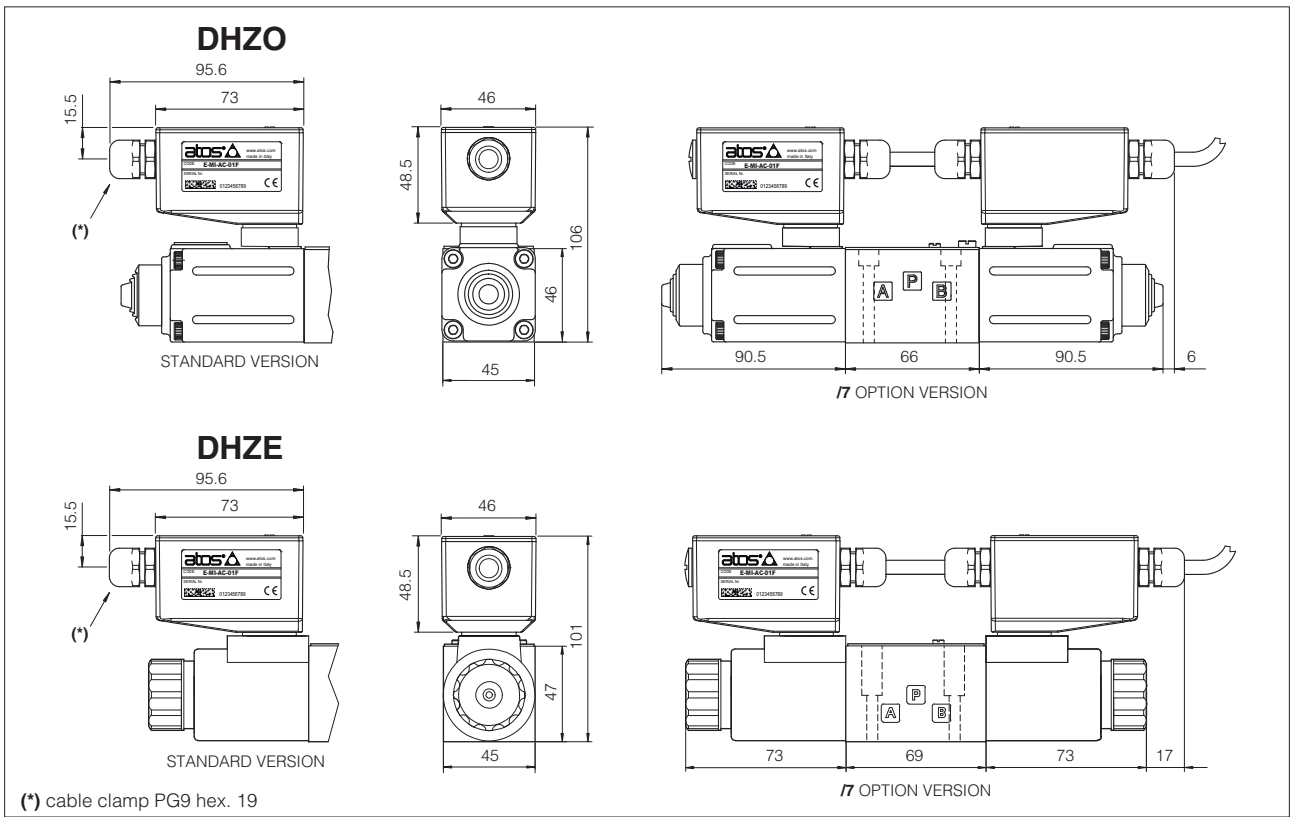

13 EARTH CONNECTIONS

