

MRSX series

Maximum working pressure up to 1 MPa (10 bar) - Flow rate up to 300 l/min



Description

Technical data

Return / Suction filter

Tank mounted

Maximum working pressure up to 1 MPa (10 bar)

Flow rate up to 300 l/min

MRSX is a range of suction/return filters for hydraulic systems with two or more circuits (both open and closed loops). They are able to provide pressurized oil cleaned by fine filtration to the feed pump of the hydrostatic systems.

They are directly fixed to the reservoir, in immersed or semi-immersed position.

The filter output must be always immersed into the fluid to avoid aeration or foam generation into the reservoir.

Available features:

- Female threaded return connections up to 1 1/4", for a maximum return flow rate of 300 l/min
- Multiple connections, to connect several return and suction lines
- Fine filtration rating, to get a good cleanliness level into the reservoir
- Bypass valve to the tank, to relieve excessive pressure drop across the filter media when the return flow is enough higher than the suction flow
- Bypass valve to the suction line with additional suction filter element, to relieve excessive pressure drop across the filter media when the return flow is not enough higher than the suction flow
- De-pressurization valve, to reduce the pressure inside the filter during the maintenance operations
- Anti-cavitation valve with additional suction filter element, to ensure fluid to the feed pump of the hydrostatic systems during cold starts or initial filling
- O-ring or Flat Seal to suit a variety of reservoir surfaces
- Reservoir side mounting, to save space in the machines
- Visual, electrical and electronic clogging indicators
- MYclean interface connection, to protect the product against non-original spare parts
- External protective wrap, to optimize the flow through the element and to save the element efficiency against non-proper handling

Common applications:

Mobile machines with hydrostatic systems on board
(i.e. skid steer loaders, telehandlers, dumpers, road sweepers)

Filter housing materials

- Head: Aluminium
- Cover
Nylon: MRSX 116
Aluminium: MRSX 165-166
- Bowl: Nylon

Δp element type

- RSX: 10 bar
- Oil flow from exterior to interior.

Seals

- Standard NBR series A
- Optional FPM series V

Temperature

From -25 °C to +110 °C

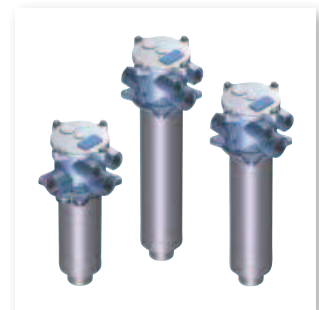

FILTER ASSEMBLY SIZING

Flow rates [l/min]

Filter series	Length	A10	A16	A25
MRSX 116	1	74	82	87
	2	108	113	124
MRSX 165 - 166	1	155	166	178
	2	187	196	200
	3	201	205	217

Maximum flow rate for a complete return/suction filter with a pressure drop Δp = 1 bar.

The reference fluid has a kinematic viscosity of 30 mm²/s (cSt) and a density of 0.86 kg/dm³.

For different pressure drop or fluid viscosity we recommend to use our selection software available on www.mpfiltr.com.

You can also calculate the right size using the formulas present on the FILTER SIZING paragraph at the beginning of the full catalogue or at the beginning of the filter family brochure. Please, contact our Sales Department for further additional information.

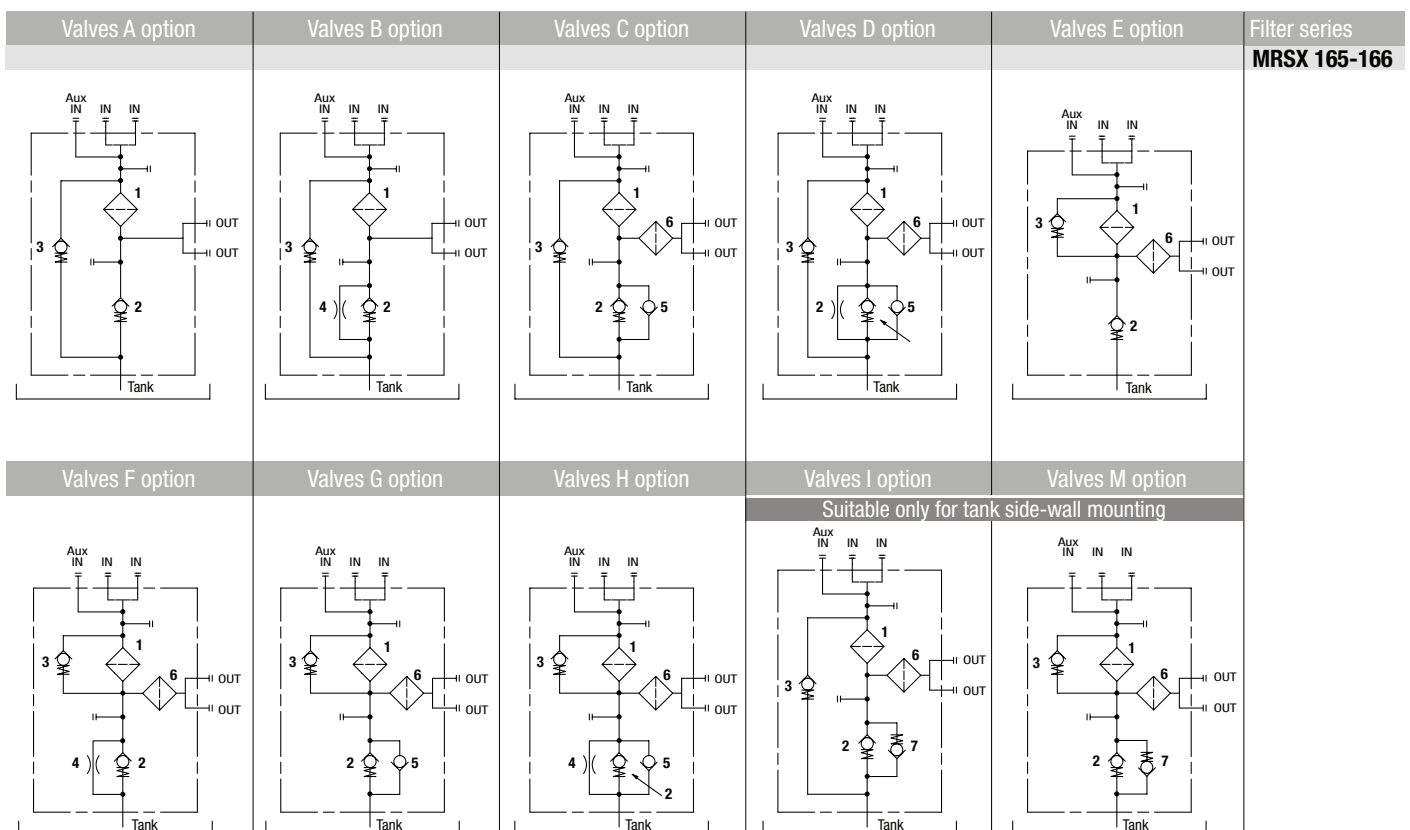
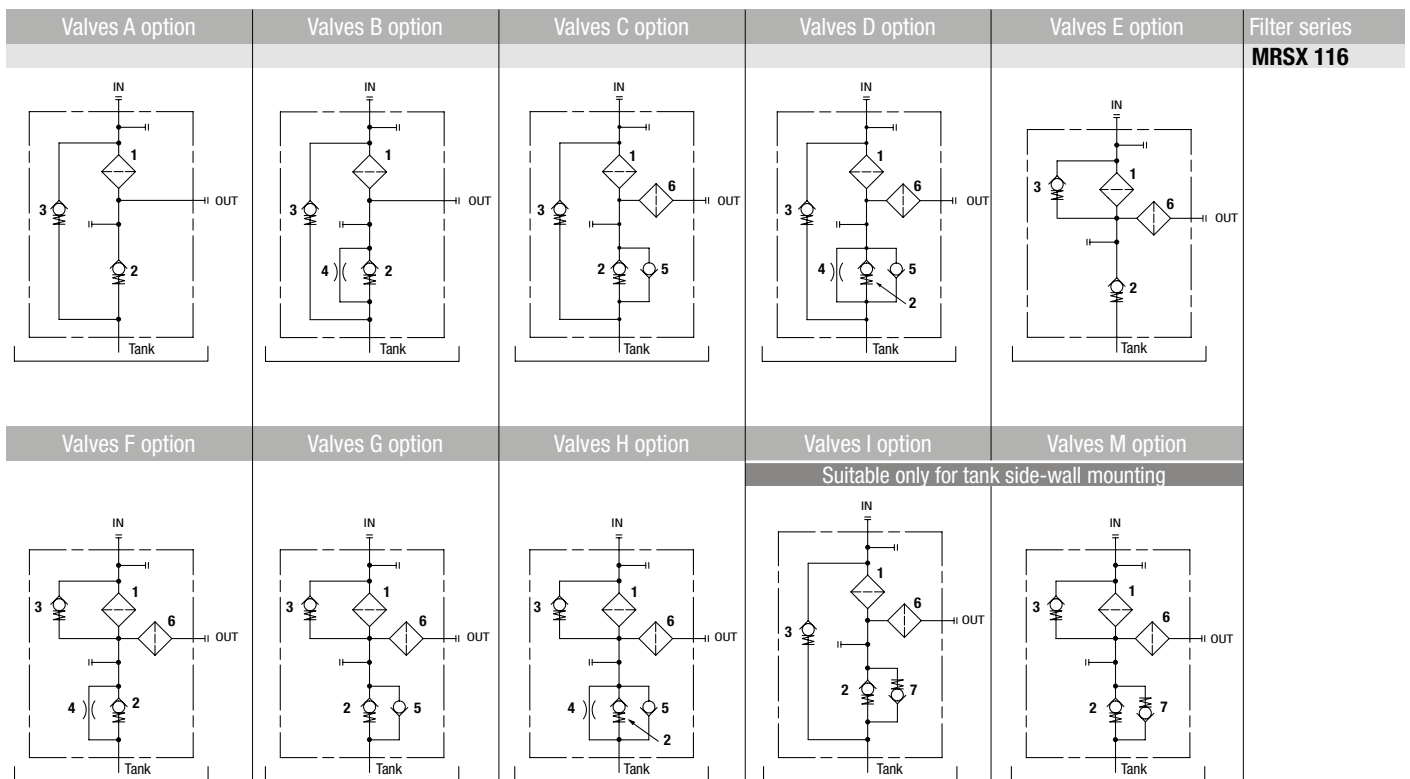

LEGEND

- 1 - Filter element
- 2 - Back-Pressure valve: opening pressure 0.5 bar \pm 10%
- 3 - Bypass valve: opening pressure 2.5 bar \pm 10%
- 4 - Depressurization valve

- 5 - Anti-Cavitation valve
- 6 - Safety filter element (wire mesh 60 μ m)
- 7 - Anti-Cavitation valve / Anti-Emptying valve

MRSX GENERAL INFORMATION

Pressure drop

Filter housings Δp pressure drop

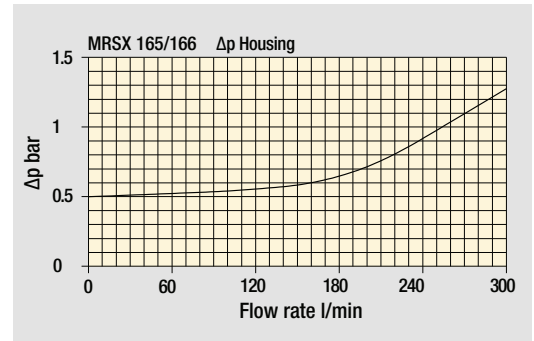
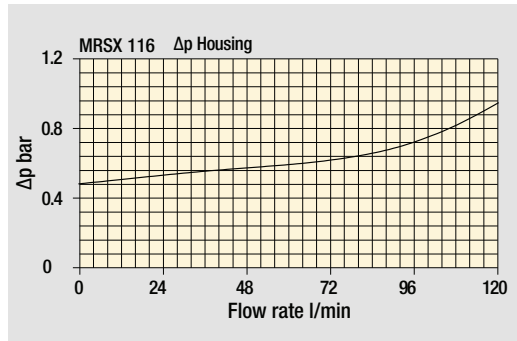

Bypass valve pressure drop

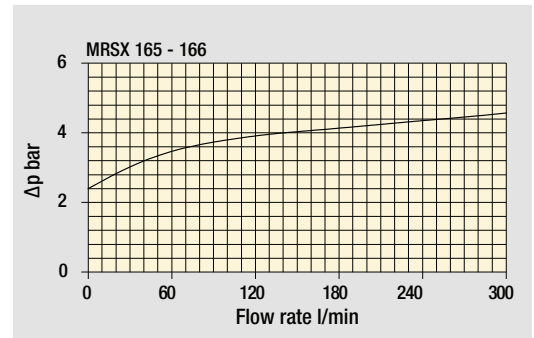
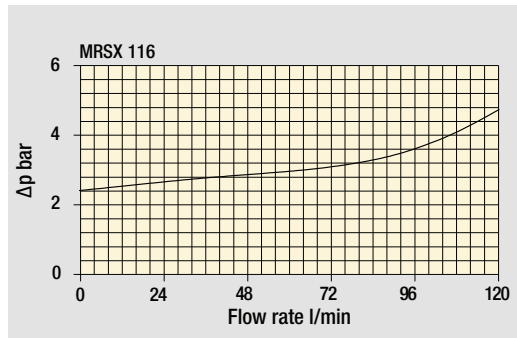

The curves are plotted using mineral oil with density of 0.86 kg/dm³ in compliance with ISO 3968. Δp varies proportionally with density.

Weights [kg] and volumes [dm³]

Filter series	Weights [kg]			Volumes [dm ³]				
	Length	1	2	3	Length	1	2	3
MRSX 116		1.30	1.40	-		0.80	1.00	-
MRSX 165		3.40	3.80	4.10		2.00	2.60	3.00
MRSX 166		3.40	3.80	4.10		2.00	2.60	3.00

MRSX MRSX165 - MRSX166

Designation & Ordering code

COMPLETE FILTER

Configuration example: **MRSX166** | **2** | **C** | **V** | **G3** | **1** | **A10** | **S** | **P01**

Series and size
MRSX165 | **MRSX166** Filter element with private spigot

Length
1 | **2** | **3**

Hydraulic diagram configuration - see page 257

				Bypass valve to tank		Bypass valve to OUT	
A	B	C	D		•		
E	F	G	H				•
I				•			
M							•

Seals and treatments

A	NBR, O-Ring on head	B	NBR, flat seal on head
V	FPM, O-Ring on head	D	FPM, flat seal on head

Connections

	IN (size 165)	IN (size 166)	Aux IN	OUT
G1	G 1 1/4"	G 1"	G 1 1/4"	G 1"
G2	1 1/4" NPT	1" NPT	1 1/4" NPT	1" NPT
G3	SAE 20 - 1 5/8" - 12 UN	SAE 16 - 1 5/16" - 12 UN	SAE 20 - 1 5/8" - 12 UN	SAE 16 - 1 5/16" - 12 UN

Aux IN connection

	MRSX 165	MRSX 166
0	Without aux IN connection	• -
1	With aux IN connection - see previous table	• •

Filtration rating (filter media)

A10 Inorganic microfiber 10 µm
A16 Inorganic microfiber 16 µm
A25 Inorganic microfiber 25 µm

Valves configuration

Mounting position	A	B	C	D	E	F	G	H	I	M
S Standard	•	•	•	•	•	•	•	•		
B Tank side-wall mounting	•	•			•	•			•	•

Execution

P01 MP Filtri standard
Pxx Customized

FILTER ELEMENT

Configuration example: **RSX165** | **2** | **A10** | **V** | **P01**

Element series and size
RSX165 Filter element with private spigot

Element length
1 | **2** | **3**

Filtration rating (filter media)

A10 Inorganic microfiber 10 µm
A16 Inorganic microfiber 16 µm
A25 Inorganic microfiber 25 µm

Seals

A	NBR
V	FPM

Execution

P01 MP Filtri standard
Pxx Customized

ACCESSORIES

Indicators on Return Line		page	Indicators on Suction Line		page
BVA	Axial pressure gauge	278	BEA	Electrical pressure indicator	276
BVR	Radial pressure gauge	278	BEM	Electrical pressure indicator	276
BVP	Visual pressure indicator with automatic reset	279	BET	Electrical pressure indicator	276-277
BVQ	Visual pressure indicator with manual reset	279	BLA	Electrical / visual pressure indicator	277-278
VVB	Axial vacuum gauge	275	VEB	Electrical vacuum indicator	274
VVS	Radial vacuum gauge	275	VLB	Electrical / visual vacuum indicator	274

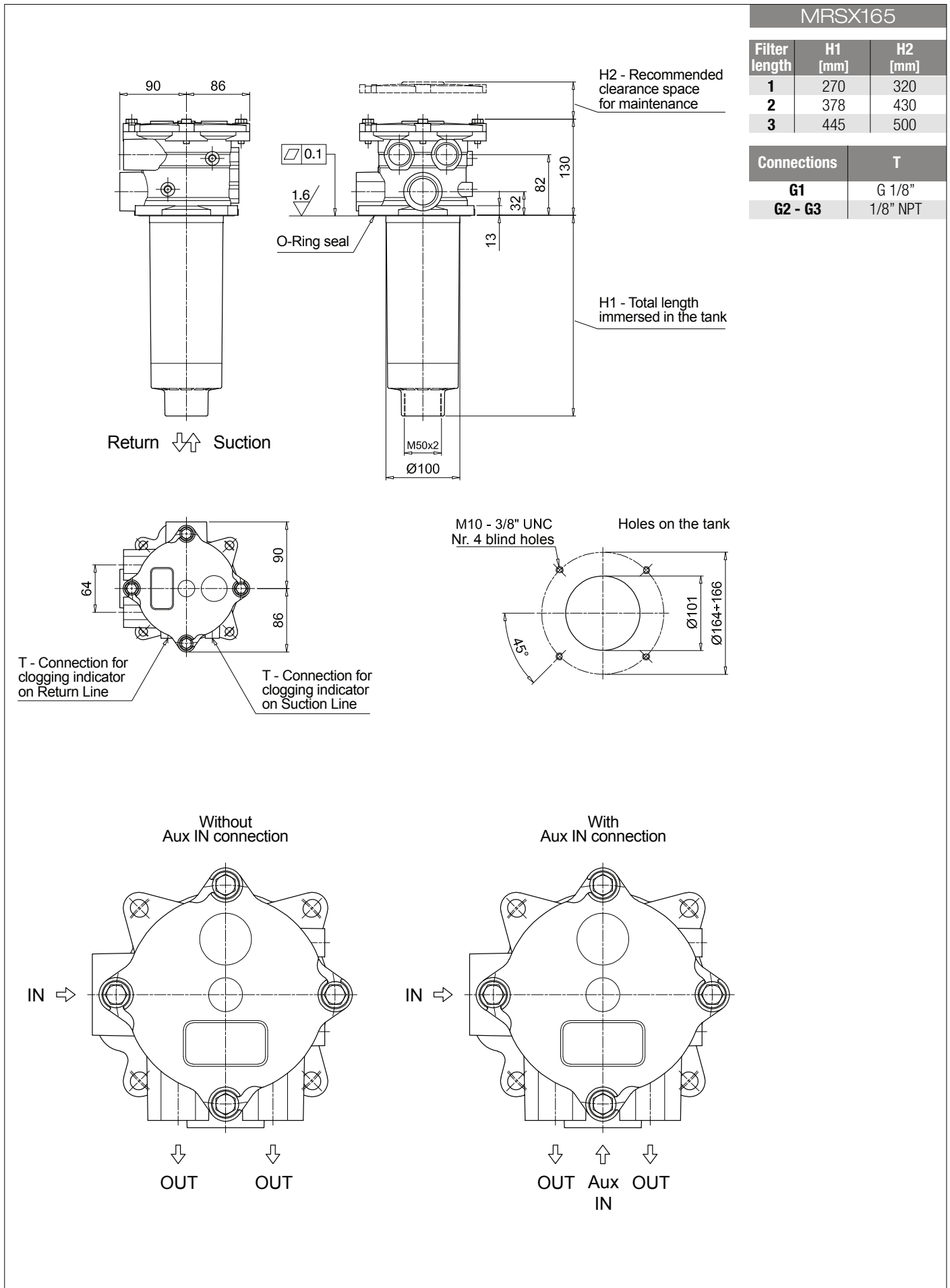

MRSX165

Filter length	H1 [mm]	H2 [mm]
1	270	320
2	378	430
3	445	500

Connections	T
G1	G 1/8"
G2 - G3	1/8" NPT

Return ↓ Suction ↑

H2 - Recommended clearance space for maintenance

H1 - Total length immersed in the tank

T - Connection for clogging indicator on Return Line
 T - Connection for clogging indicator on Suction Line

M10 - 3/8" UNC Nr. 4 blind holes
 Holes on the tank

Without Aux IN connection

With Aux IN connection

IN →

IN →

↓ OUT ↓ OUT

↓ OUT ↑ Aux IN ↓ OUT

MRSX MRSX165 - MRSX166

Dimensions

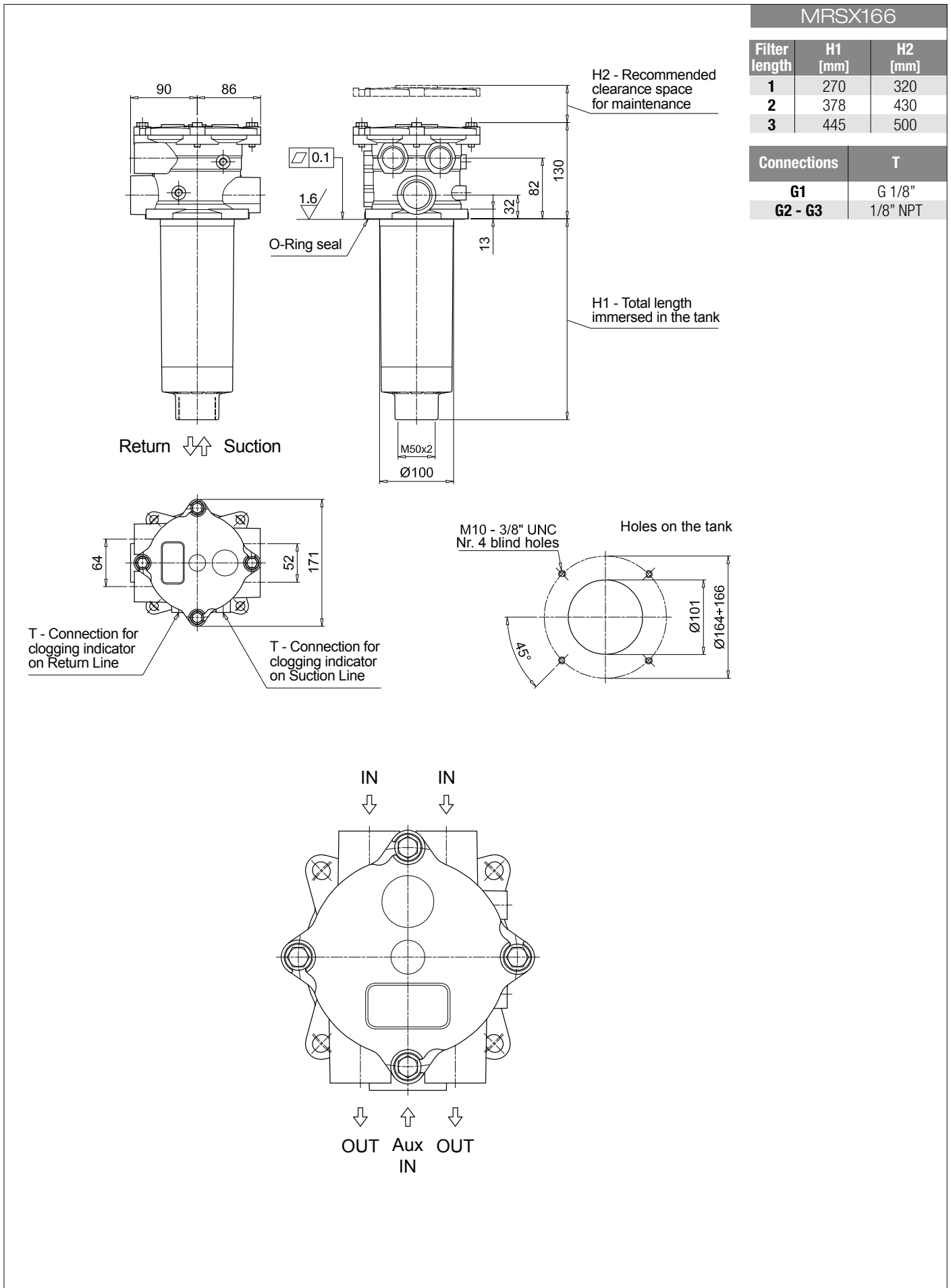

MRSX 116

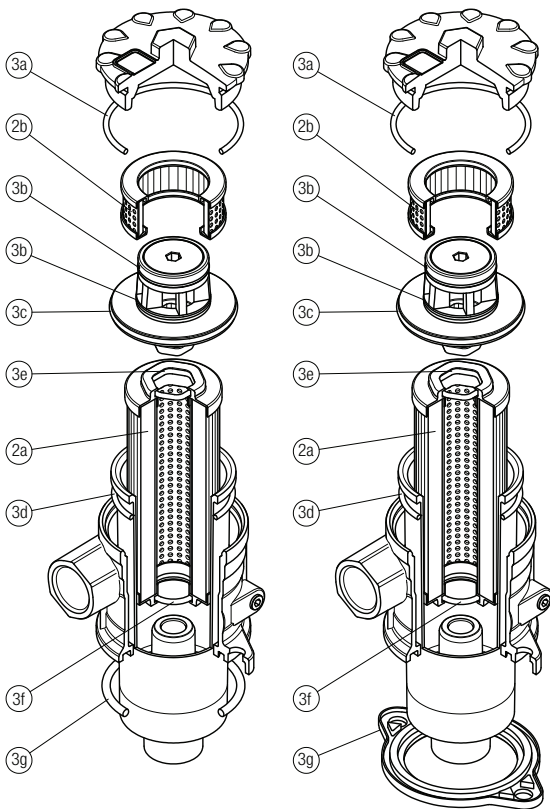

Item:	Q.ty: 1 pc.	Q.ty: 1 pc.	O-RING SEAL		FLAT SEAL	
	2a	2b	3 (3a ÷ 3g)		3 (3a ÷ 3g)	
Filter series	Filter element	Safety filter element	Seal Kit code number NBR	Seal Kit code number FPM	Seal Kit code number NBR	Seal Kit code number FPM
MRSX 116	See order table	S116M60P01	02050617	02050619	02050618	02050620

MRSX 165 - 166

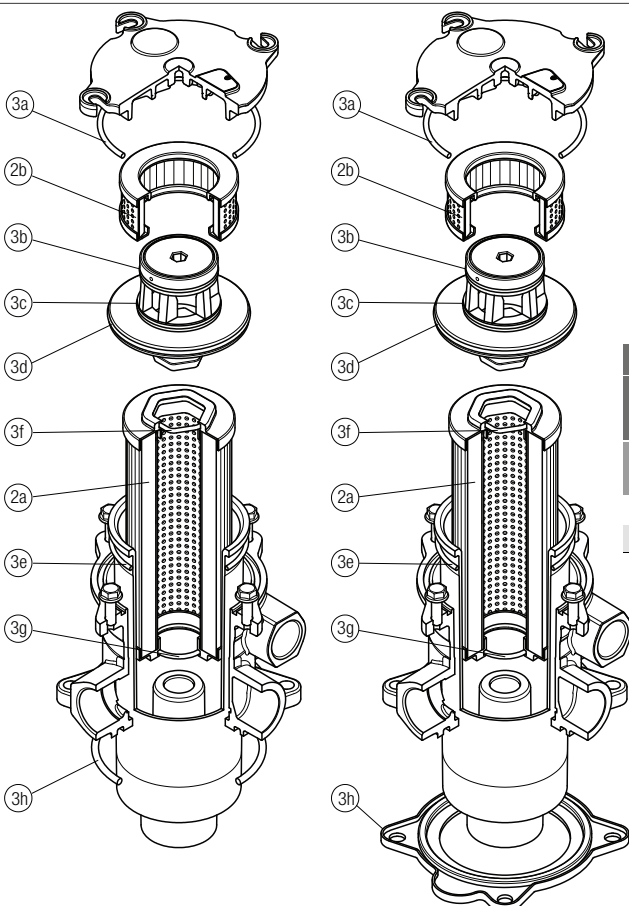

Item:	Q.ty: 1 pc.	Q.ty: 1 pc.	O-RING SEAL		FLAT SEAL	
	2a	2b	3 (3a ÷ 3h)		3 (3a ÷ 3h)	
Filter series	Filter element	Safety filter element	Seal Kit code number NBR	Seal Kit code number FPM	Seal Kit code number NBR	Seal Kit code number FPM
MRSX 165	See order table	S165M60P01	02050627	02050630	02050628	02050631
MRSX 166			02050627	02050630	02050629	02050632