

ICM 2.0

In-Line Contamination Monitor



Description

Automatic Particle Counters

In-Line Contamination Monitor

The ICM 2.0 automatically measures and displays particulate contamination, moisture and temperature levels in various hydraulic fluids.

It is designed specifically to be mounted directly to systems, where ongoing measurement or analysis is required, and where space and costs are limited.

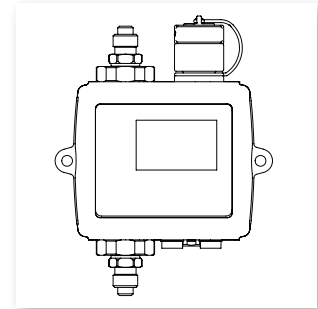

> Features & Benefits

- 8 channel contamination measurement & display
- Measures and displays the following international standard formats: ISO 4406:2017, NAS 1638, AS 4059E
- Moisture and temperature sensing fluid dependent
- Data logging and 4000 test result memory
- Manual, automatic and remote control flexibility
- Multicolour indicators via LCD (K versions) and LED with output alarm signals as standard
- Robust die cast aluminium construction
- LPA View software (included)
- Pressure max. 420 bar
- Environmental protection IP65/67 versatile
- Secondary connector to allow the simultaneous control/download of results during operation
- Option available to download all results onto a USB stick, direct from the ICM
- 4-20mA analogue output as standard

Scope of Supply

- 1 x ICM 2.0 (Specific model will be as per ordered item)
- 1 x 3m Twisted Pair Cable Assembly
- 1 x Hard copy Quick start/wiring installation guide
- 1 x Hard copy Fluid Condition Handbook
- 1 x Digital copy of user guides/software/drivers
- 1 x Hard copy of calibration certificate

See Accessories at page 83.

Status LED

All ICM 2.0 versions have a multicolour indicator on the front panel, which is used to indicate the status or alarm state. ICM-K versions also have a screen that changes colour. The alarm thresholds can be set from LPA-View via the serial interface.

Screen and multicolor indicators

- Green indicates that the test result passed, i.e. none of the alarm thresholds were exceeded
- Yellow indicates that the lower cleanliness limit was exceeded, but not the upper one
- Red indicates that the upper cleanliness limit was exceeded
- Blue indicates that the upper water content limit was exceeded
- Red/Blue Alternating indicates both cleanliness and water content upper limits exceeded
- Violet indicates that the upper temperature limit was exceeded



Left facing view



Right facing view



Top view with USB port



Bottom view

Technical data

Technology

LED Based Light Extinction Automatic Optical Contamination Monitor

Particle Sizing

>4, 6, 14, 21, 25, 38, 50, 70 $\mu\text{m}_{(c)}$ to ISO 4406:2017 Standard

Analysis range

ISO 4406:2017 Code 0 to 25

NAS 1638 Class 00 to 12

AS4059 Rev. E Table 1&2 Sizes A-F: 000 (Lower Limits are Test Time dependent)

Accuracy

$\pm \frac{1}{2}$ code for 4,6,14 $\mu\text{m}_{(c)}$ ± 1 code for larger sizes

Calibration

Each unit individually calibrated with ISO Medium Test Dust (MTD) based on ISO 11171, on equipment certified by I.F.T.S. ISO 11943

Operating Flow Rate

20 - 400 ml/minute

Viscosity range

≤ 1000 cSt

Fluid temperature

From -25 °C to +80 °C

Ambient Temperature

From -25 °C to +80 °C (non K version)

From -25 °C to +55 °C (K version)

Temperature Measurement

± 3 °C

Pressure

Maximum: 420 bar

Test time

Adjustable 10 - 3600 seconds. Factory set to 120 seconds.

Start delay & programmable test intervals available as standard

Flow rate measurement

Indicator only

Data Storage

4000 tests

Communication options

RS485, MODBUS, CANBUS, 4-20mA time multiplex as standard

Relays

Two solid state relays fitted to "R" version for output to alarm circuits

Environmental Protection

IP 65/67 versatile IK04 Impact Protection

Moisture Sensing

% RH (Relative Humidity) $\pm 3\%$

Weight

1.6 kg

Electrical Supply

Voltage 9-36V DC

Power consumption

<2.2 W

Outer Casing Finish

Polyurethane BS X34B. Colour BS381-638 (Dark Sea Grey)

Industry 4.0 ready with appropriate accessory product

Wetted parts

M - C46400 Cu alloy, 316 stainless steel, FPM, FR4, sapphire.

N - 316 stainless steel, FPM, sapphire.

S - 316 stainless steel, perfluoro elastomer, sapphire, EPDM.

Software

LPA View software (included)

LPA View Software

The LPA View software is used with the LPA3, LPA2, CML2 and ICM particle counters. When connected to LPA View, MP Filtri CMPs can transfer results in realtime, or alternatively, historical results can be downloaded from the CMP's inbuilt memory.

- Runs on Windows XP, 7, and Windows 10
- Full adjustment & control of product settings, test times and alarms
- Easy test report generation
- Trend analysis
- Graphical display options
- Universal format across our contamination monitoring product range

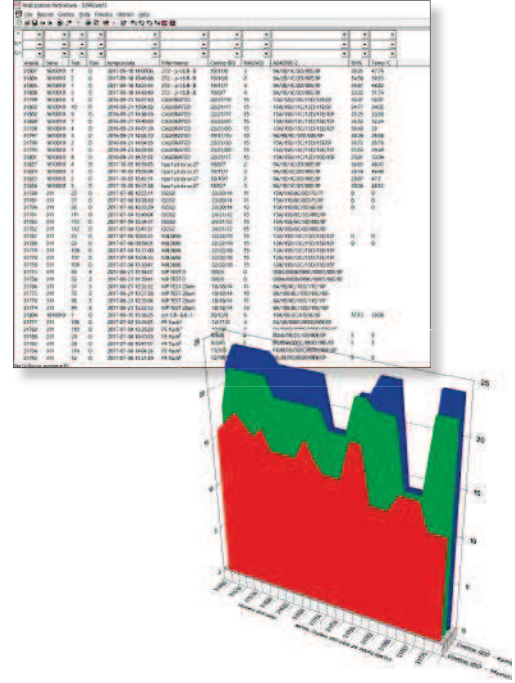

Hydraulic Circuit

TYPICAL PRESSURE LINE

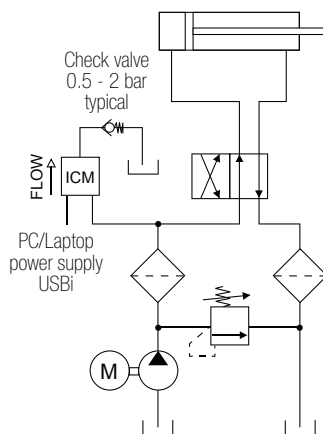

TYPICAL RETURN LINE

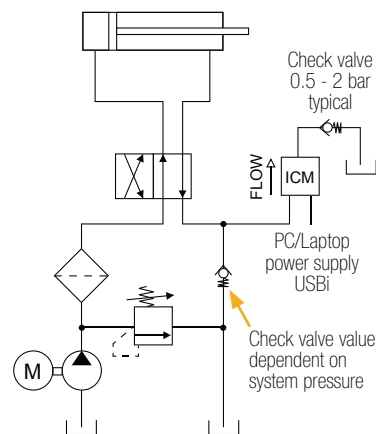

For installation guidance please visit www.mpfiltri.co.uk/ICM-2_0/#Home

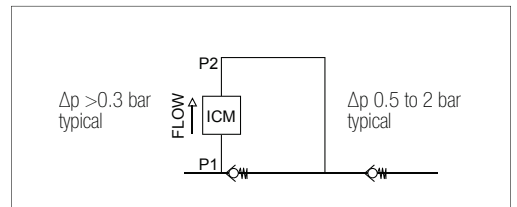

Dimensions

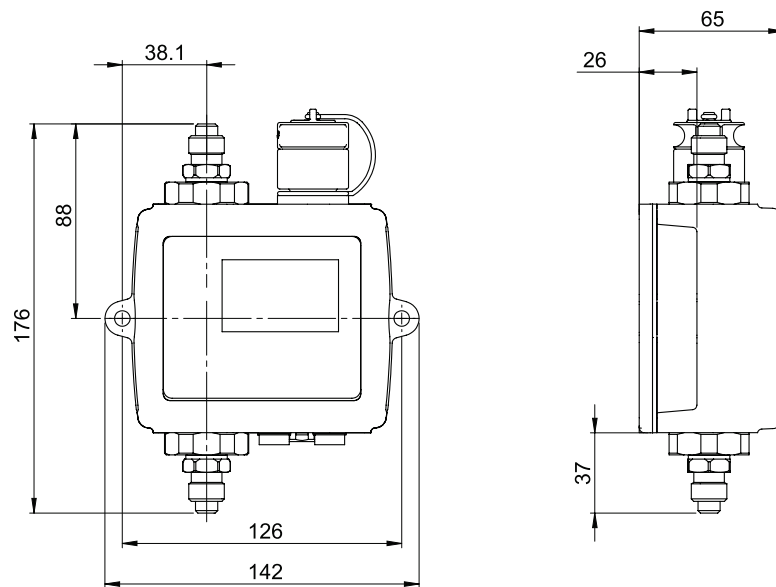

It is important to ensure a 0.5 - 2 bar differential across the ICM 2.0

The ICM 2.0 can be used as a standalone product or can be controlled by external PC, PLC or the ICMRDU2.0 (Remote Display Unit. 10m control cable supplied as standard).

Designation & Ordering code

AUTOMATIC PARTICLE COUNTER ICM 2.0

Series	Configuration example:	ICM	W	M	K	R	G1	2.0
ICM In-Line Contamination Monitor								
Moisture Sensor (RH%)								
0 Without moisture and temperature sensor								
W With moisture and temperature sensor								
Fluid compatibility								
M Mineral/synthetic oils								
N Subsea fluids and water based fluids (*)								
S Phosphate ester and aggressive fluids (*)								
Keypad / Display								
0 Without keypad / display								
K With keypad / display								
Device output								
R With relays / external alarm outputs								
U Test record transfer (direct to USB stick) plus relays/external alarm outputs								
Connections								
G1 ICM complete with M16 x 2 pressure test point connections fitted								
G3 1/4" BSP - Female port								
G4 7/16" UNF - Female port								
Series								
2.0								

(*) **N** and **S** version, moisture sensor (**W**) not available