

MPH series

Maximum working pressure up to 1 MPa (10 bar) - Flow rate up to 3000 l/min



Description

Technical data

Return filter

Maximum working pressure up to 1 MPa (10 bar)
Flow rate up to 3000 l/min

MPH is a range of return filters for protection of the reservoir against the system contamination.

They are directly fixed to the reservoir, in immersed or semi-immersed position.

The use of the diffuser is recommended, to place the filter output always immersed into the fluid to avoid aeration or foam generation into the reservoir.

The filtration from inside to outside allows a cleaner filter element replacement, the dirty remains into the filter element.

Available features:

- Female threaded connections up to 1 1/2" and flanged connections up to 4", for a maximum flow rate of 3000 l/min
- Multiple connections, to connect several return lines or drains
- Fine filtration rating, to get a good cleanliness level into the reservoir
- Bypass valve, to relieve excessive pressure drop across the filter media
- Magnetic column, to hold the ferrous particles
- 2, 3, 4 or 8 fixing holes for installation, to meet any reservoir surface flatness and roughness
- Flat seal, to meet any reservoir surface flatness and roughness
- Oil dipstick, to easily check the level of the fluid into the reservoir (separate item)
- Diffuser, to reduce the risk of aeration, foaming and noise
- Filler plug, to fill cleaned fluid into the tank without an additional plug
- Integrated breather filter, to clean the air that moves into the reservoir as result of the oil level fluctuation (MPH110/114)
- Integrated breather filter with pressurization valve, to clean the air that moves into the reservoir as result of the oil level fluctuation and to guarantee the pressurization into the reservoir (MPH110/114)
- Visual, electrical and electronic clogging indicators

Common applications:

Heavy duty industrial equipment

Filter housing materials

- Head
 - Aluminium: MPH 110-114-116-120-250
 - Anodized Aluminium: MPH 630-850
 - Painted Aluminium: MPH 660

- Cover
 - Nylon: MPH 110-114-116-120
 - Aluminium: MPH 250
 - Anodized Aluminium: MPH 630
 - Painted Aluminium: MPH 660
 - Steel: MPH 850

- Insert assembly
 - Nylon: MPH 110-114-116-120
 - Aluminium: MPH 250-630-660-850

- Diffuser: Tinned Steel

- Valve: Phosphatized Steel

Bypass valve

- Opening pressure 175 kPa (1.75 bar) ±10%
- Opening pressure 250 kPa (2.5 bar) ±10%, except for MPH 850

Δp element type

- Microfibre filter elements - series MR: 10 bar
- Fluid flow through the filter element from IN to OUT

Seals

- Standard NBR series A
- Optional FPM series V

Temperature

From -25 °C to +110 °C

Note

MPH filters are provided for vertical mounting



Weights [kg] and volumes [dm³]

Filter series	Weights [kg]					Volumes [dm³]						
	Length	1	2	3	4	5	Length	1	2	3	4	5
MPH 110	1.60	1.70	1.80	2.20	2.60		1.60	1.70	1.80	2.20	2.60	
MPH 114	1.60	1.70	1.80	2.20	2.60		1.60	1.70	1.80	2.20	2.60	
MPH 116	1.60	1.70	1.80	2.20	2.60		1.60	1.70	1.80	2.20	2.60	
MPH 120	1.60	1.70	1.80	2.20	2.60		1.60	1.70	1.80	2.20	2.60	
MPH 250	3.60	3.90	4.20	5.60	-		4.40	4.40	5.40	8.00	-	
MPH 630	6.50	7.00	7.40	8.50	10.50		7.30	9.00	11.00	13.00	19.20	
MPH 660	-	-	-	11.50	14.00		-	-	-	14.60	21.00	
MPH 850	32.00	35.00	38.00	42.00	-		13.00	16.50	21.00	25.00	-	

Filter housings Δp pressure drop

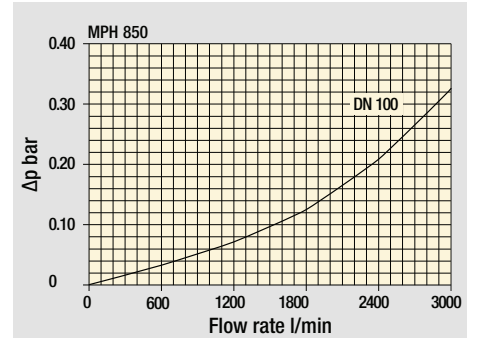
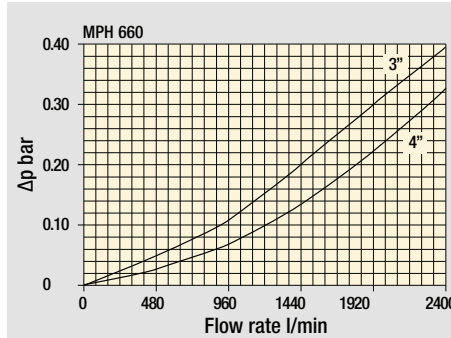
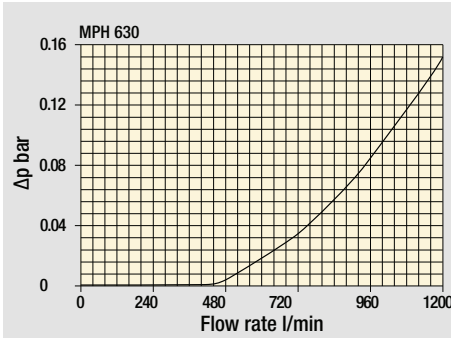
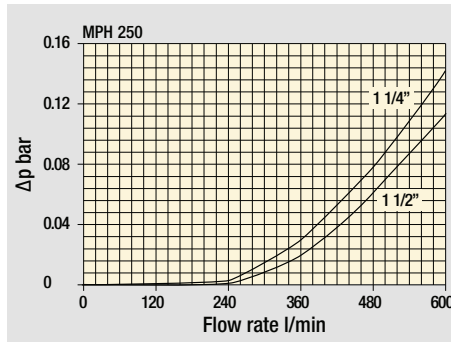
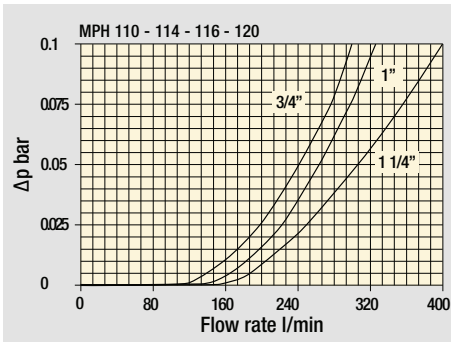

Bypass valve pressure drop

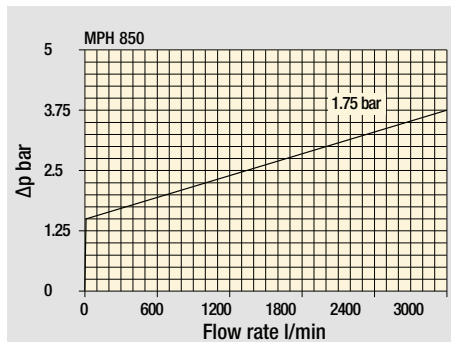
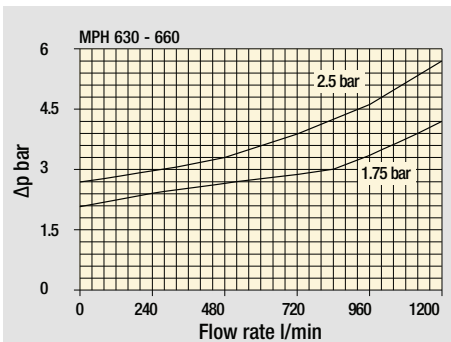
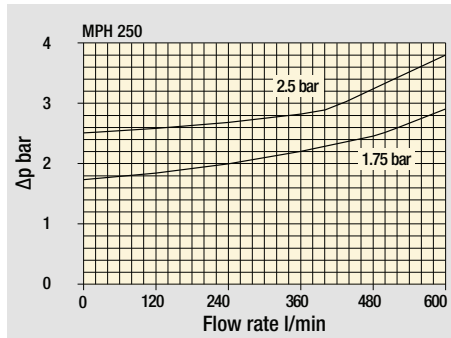
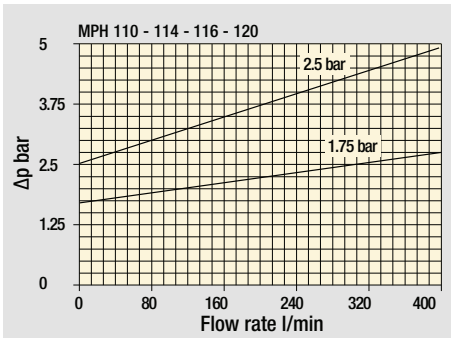

Air breather pressure drop

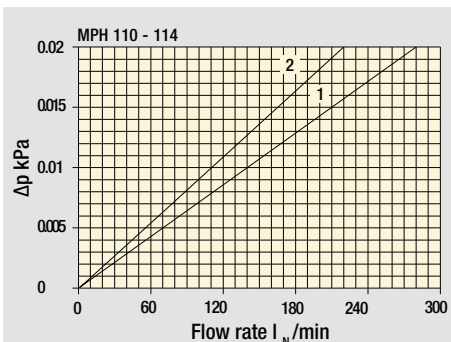

- 1 C With air breather 10 μ m
- 2 D With anti-splash and SAP50 10 μ m

The curves are plotted using mineral oil with density of 0.86 kg/dm³ in compliance with ISO 3968.
 Δp varies proportionally with density.

MPH GENERAL INFORMATION

Flow rates [l/min]

Filter series	Length	A03	A06	A10	A16	A25	M25 M60 M90	P10	P25
MPH 110-114 116-120	1	26	29	72	79	107	282	164	190
	2	43	46	112	114	161	318	164	190
	3	64	72	132	156	178	324	219	251
	4	90	99	184	198	216	324	266	302
	5	117	128	201	219	244	324	282	318
MPH 250	1	93	102	210	251	315	1093	339	383
	2	124	151	327	412	421	1122	460	514
	3	189	221	418	445	500	1137	544	616
	4	261	304	592	670	766	1166	832	923
MPH 630	1	160	200	369	423	518	1894	565	632
	2	240	257	571	611	1045	1929	1137	1285
	3	330	374	745	788	1308	1938	1416	1577
	4	374	403	887	1010	1348	1956	1448	1612
	5	625	698	1210	1257	1723	2121	1839	1929
MPH 660	4	370	399	903	1042	1460	2376	1596	1830
	5	624	699	1282	1343	1997	2663	2182	2331
MPH 850	1	775	1041	1246	1568	2242	3311	2371	2625
	2	1176	1522	1682	1747	2449	3378	2684	2886
	3	1490	1914	1995	2014	3035	3405	3144	3220
	4	1668	2088	2305	2363	3169	3517	3272	3378

Maximum flow rate for a complete return filter with a pressure drop $\Delta p = 0.5$ bar.

The reference fluid has a kinematic viscosity of 30 mm²/s (cSt) and a density of 0.86 kg/dm³.

For different pressure drop or fluid viscosity we recommend to use our selection software available on www.mpfiltri.com.

Please, contact our Sales Department for further additional information.

Hydraulic symbols

Filter series	Style 1 connection	Style 2 connections	Style 3 connections
MPH 110		•	
MPH 114	•		
MPH 116	•		
MPH 120			•
MPH 250	•	•	
MPH 630	•	•	
MPH 660	•		
MPH 850		•	

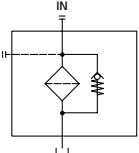
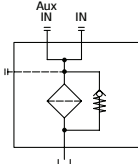
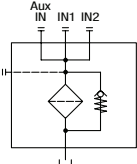
		
---	---	---

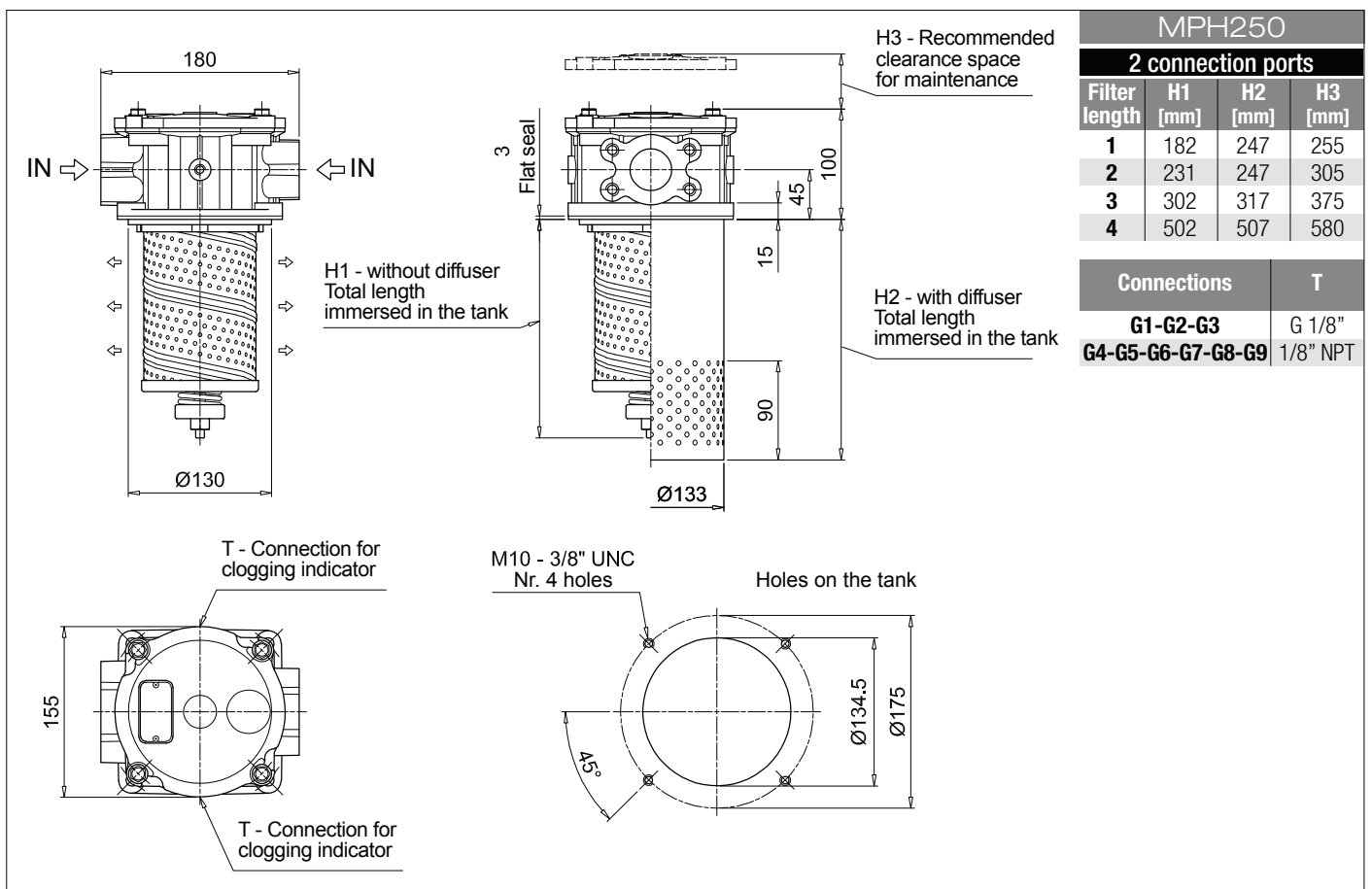
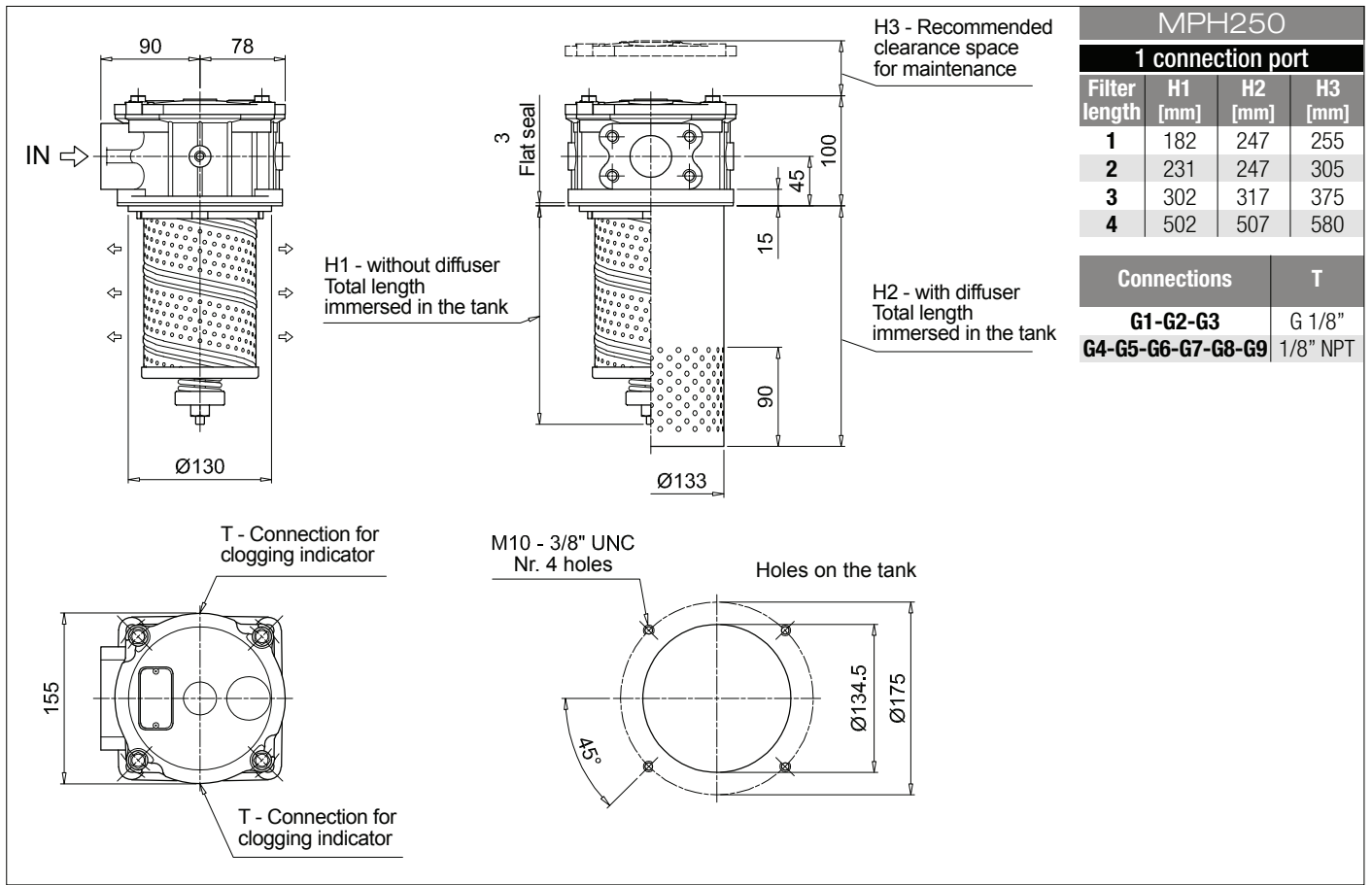

MPH 250 - 630

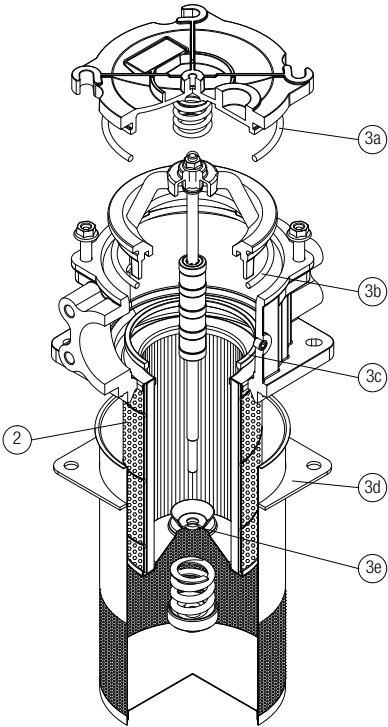

Item:	Q.ty: 1 pc.	Q.ty: 1 pc.	
Filter series	Filter element	Seal Kit code number	
MPH 250	MPH 630	NBR	FPM
	2	3 (3a ÷ 3e)	
	See order table	02050151	02050152
	See order table	02050153	02050154

MPH 660

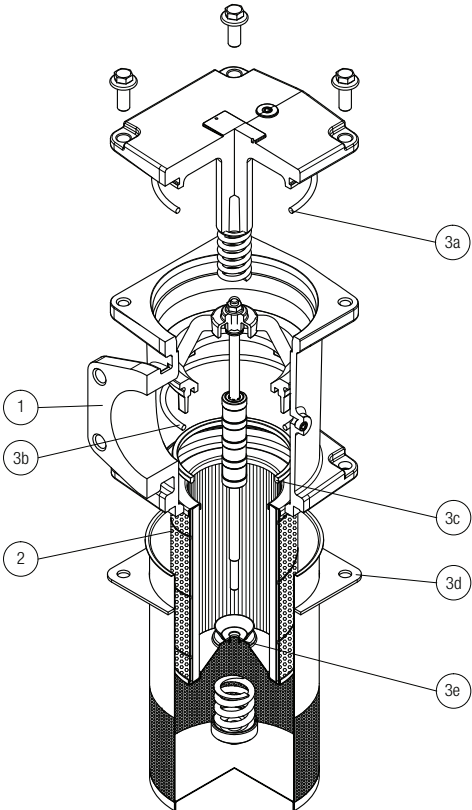

MPH 850

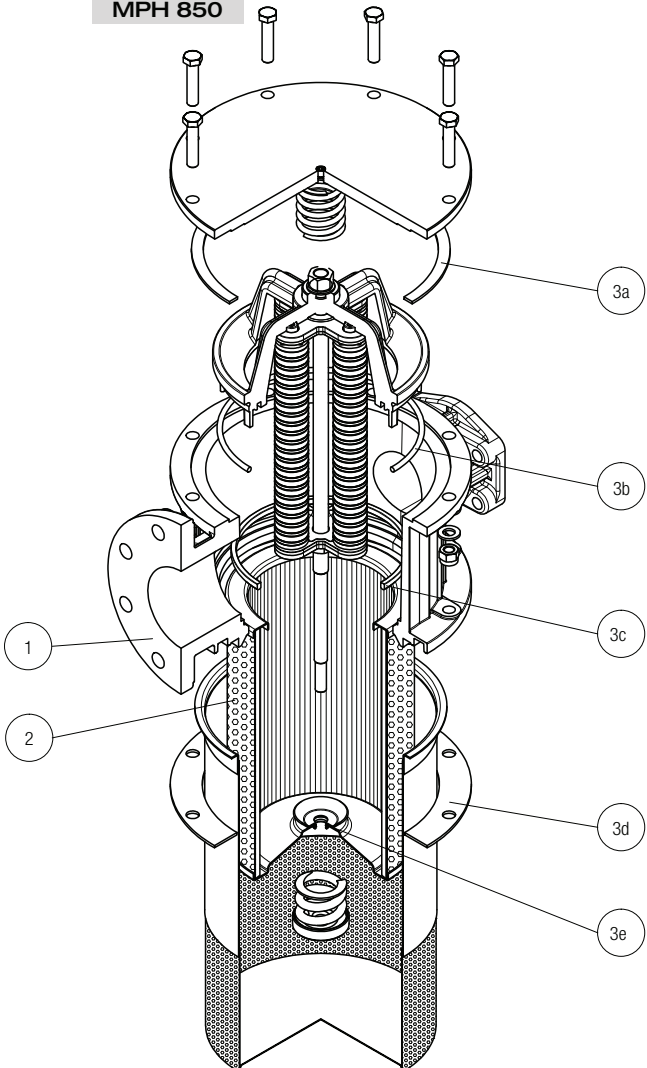

Item:	Q.ty: 1 pc.	Q.ty: 1 pc.	
Filter series	Filter element	Seal Kit code number	
MPH 660	MPH 850	NBR	FPM
	2	3 (3a ÷ 3e)	
	See order table	02050153	02050154
	See order table	02050155	02050156