

Dimensions

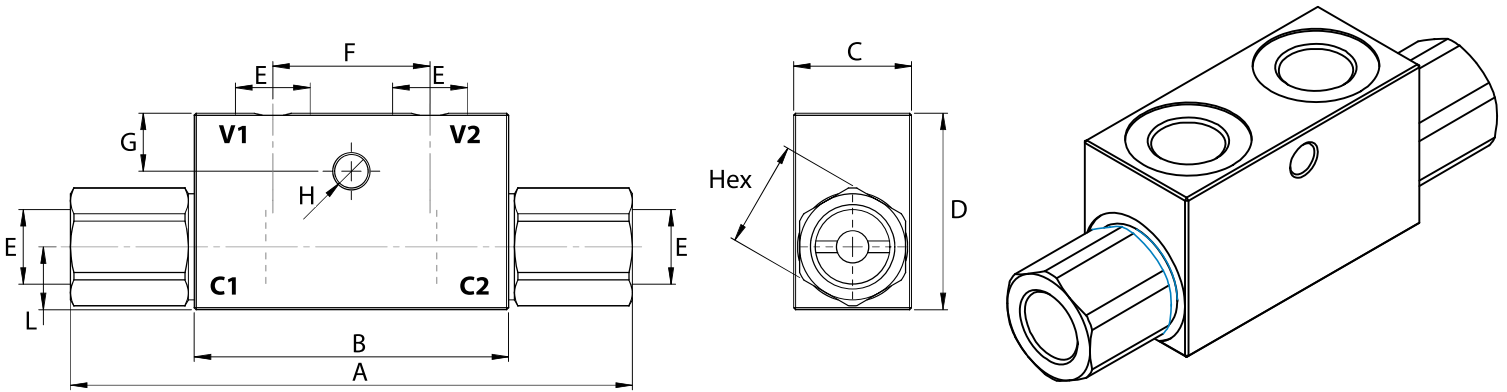

Size	A	B	C	D	E BSP	F	G	H	L	Hex	Weight kg
01	117	68	30	40	1/4	38	7	7	13	24	0,67
15	117	68	30	40	3/8	38	7	7	13	24	0,63
02	143	80	30	50	3/8	40	15	8,5	16	27	0,96
25	143	80	30	50	1/2	40	15	8,5	16	27	0,89
03	144	80	35	50	1/2	36	15	6,5	16	27	1,07
04	192	100	40	60	3/4	50	15	8,5	22	36	1,90
05	232	112	50	70	1	58	17	8,5	25	42	3,10

Hydraulic Symbol

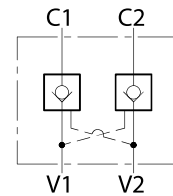

Curves

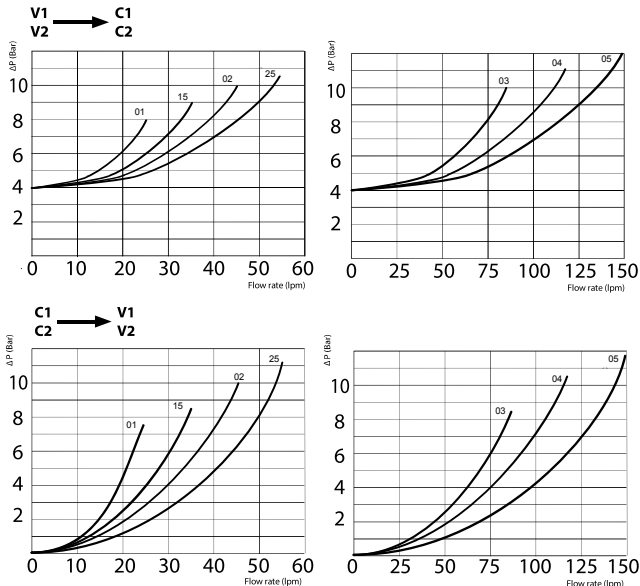

Features

Size	01	15	02	25	03	04	05
Max Pressure (bar)	350	350	300	300	300	300	300
Max Flow (lpm)	25	30	45	50	80	120	150
Pilot Ratio	1:4,6	1:4,6	1:4	1:4	1:4	1:3,5	1:3,4
Cracking Pressure (bar)	4	4	4	4	4	4	4

Materials: Zinc plated steel body, hardened steel inner parts.

Ordering Code

LVDT - -

	Size BSP
01	1/4
15	3/8
02	3/8
25	1/2
03	1/2
04	3/4
05	1

Ordering Code Example: LVDT15 = 3/8 BSP, 30 lpm.