

ASSIALI AXIAL	—	• DARK	
		UNI 3 fori / UNI 3 holes	pag. 03
		ISO 4 fori / ISO 4 holes	pag. 07
		ISO SHORT 4 fori / ISO SHORT 4 holes	pag. 11
		SAE-B	pag. 13
		• 2PAK	
ISO 4 fori / ISO 4 holes	pag. 17		
ISO 4 fori / ISO 4 holes			
doppia mandata / twin delivery	pag. 21		
ASSE INCLINATO BENT AXIS	—	• HDS - MDS	
		ISO 4 fori / ISO 4 holes	pag. 27
		UNI 3 fori / UNI 3 holes	pag. 59
		• HDT	
		ISO 4 fori / ISO 4 holes	pag. 43
		• TWIN FLOW	
		53+35	
		53+53	
		70+35	
		70+53	
		76+76	pag. 51
		• HDS - MDS	
SAE-B	pag. 69		
SAE-BB	pag. 71		
SAE-C	pag. 73		
ACCESSORI E RICAMBI ACCESSORIES AND SPARE PARTS	—	• VALVOLE BY-PASS	
		BY-PASS VALVES	
		HDS 12-17-25-34	pag. 77
		HDS - MDS - HDT	pag. 81
		TWIN FLOW	pag. 85
		• PANNELLO CON VALVOLA DI MAX.	
		RELIEF VALVE ASSEMBLY	pag. 89
		• KIT RACCORDI	
		FITTINGS KIT	pag. 91

POMPE A PISTONI FISSAGGIO 3 FORI-UNI

CODICE FAMIGLIA
FAMILY CODE

108005

3 HOLES-UNI HYDRAULIC PISTON PUMPS

"DARK" UNI

99740060010

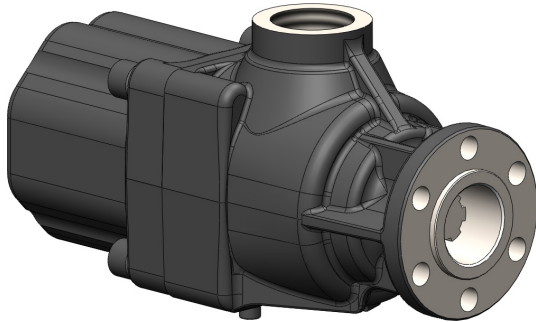

Fluido idraulico Fluid	Minerale o sintetico compatibile con guarnizioni: Mineral or synthetic compatible with the following seals: NBR, FKM, FPM, Nylon				
Viscosità cinematica consigliata Kinematic viscosity suggested	T media ambiente (°C) Average ambient temp. (°C)	< -10	-10 ÷ 10	10 ÷ 35	> 35
	VG (cSt = mm ² /s)	16	22	32	46
Viscosità cinematica ottimale di esercizio Optimale kinematic viscosity		VG= 10 cSt ÷ 100 cSt			
Viscosità cinematica max consentita all'avviamento Max kinematic viscosity suggested at the start-up		VG= 750 cSt			
Indice di viscosità consigliato Viscosity index suggested	VI > 100	Temperatura di esercizio Working temperature -15°C ÷ 100°C			
Grado di filtrazione Oil filtering		> 200 bar: 10 µm < 200 bar: 25 µm			
Pres. di aspirazione Inlet pressure		0,85 ÷ 2 bar assoluti/absolut			
Senso di rotazione Pump rotation		Bidirezionale Bidirectional			
Verificare che la pompa sia posizionata almeno 100 mm sotto il livello minimo del serbatoio olio. Prima di avviare la pompa effettuare spurgo aria. Verify that pump is, at least, 100 mm under the minimum level of the tank. Before starting the pump bleed the air.					

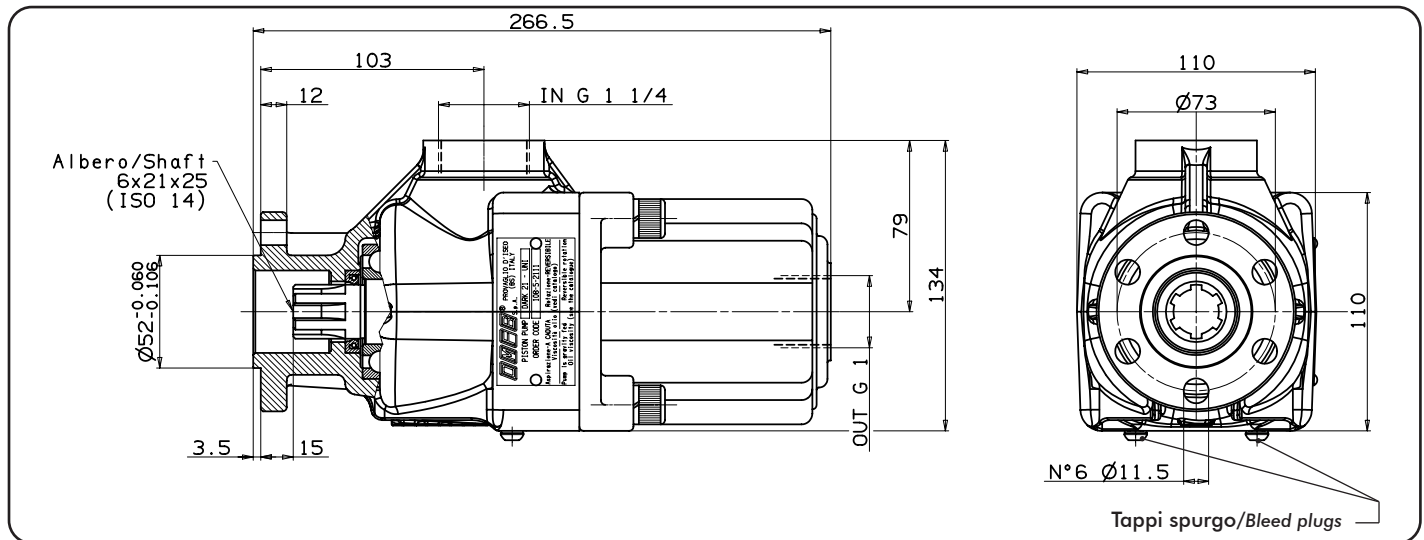

07/11/2019

99710800510 Rev. AG

Tipo pompa Pump type	Codice Code	Cilindrata Displacement cm ³ /rev	Pressione Pressure		Velocità massima Max speed rpm	Peso Weight kg
			Massima Max bar	Picco Peak bar		
DARK-21	10800502111	20,25	350	400	1800	13,9
DARK-28	10800502817	27				13,8
DARK-35	10800503512	33,75				13,8
DARK-42	10800504217	40,5				13,7
DARK-48	10800504815	47,25				13,6
DARK-52	10800505216	51,97				13,5
DARK-55	10800505510	54	300	350	1500	13,5
DARK-60	10800505912	59,3				13,5

pag.3



O.M.F.B. S.p.A. Hydraulic Components
We reserve the right to make any changes without notice.
Edition 2016.06 No reproduction, however partial, is permitted.
Via Cave, 7/9 25050 Provaglio d'Iseo (Brescia) Italy Tel.: +39.030.9830611
Fax: +39.030.9839207-208 Internet:www.omfb.it e-mail:contatti@omfb.it

COMPANY WITH
QUALITY SYSTEM
CERTIFIED BY DNV GL
= IATF 16949 =

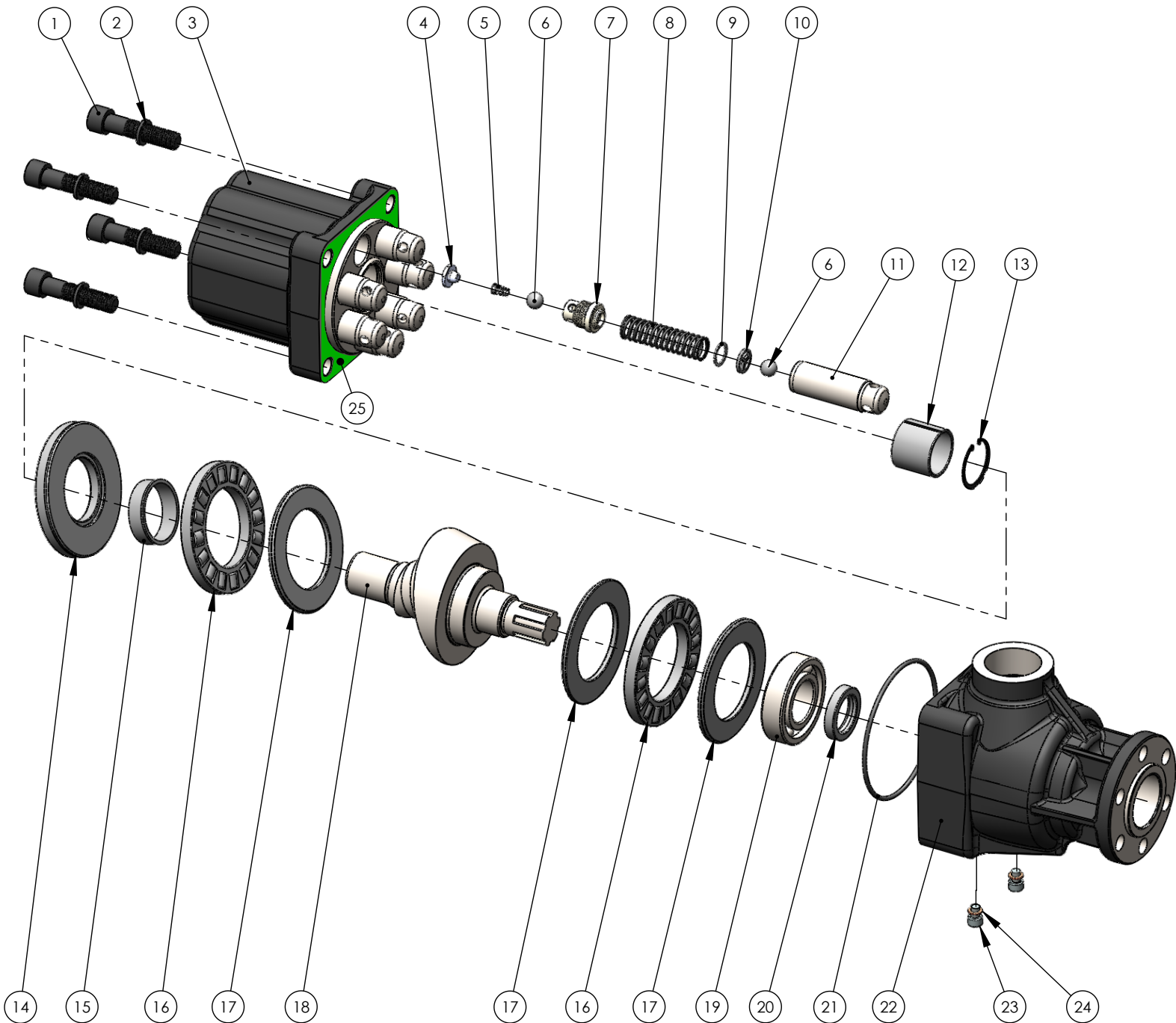

pag. 4

COMPANY WITH
QUALITY SYSTEM
CERTIFIED BY DNV GL
= IATF 16949 =

O.M.F.B. S.p.A. Hydraulic Components
We reserve the right to make any changes without notice.
Edition 2016.06 No reproduction, however partial, is permitted.
Via Cava, 7/9 25050 Prosecco d'Isoe (Brescia) Italy Tel.: +39 030.9830611
Fax: +39 030.9839207-208 Internet: www.omfb.it e-mail:contatti@omfb.it





N°	21	28	35	42	48	52	55	60	Codice/P. Number	Descrizione / Description		Q.
1	•	•	•	•	•	•	•	•	50200500591	Vite TCE M12x55 UNI 5931	Socket head capscrew M12x55	4
2	•	•	•	•	•	•	•	•	50100800063	Rondella elastica	Washer	4
3	•								51700200011	Corpo posteriore	Rear body	1
		•							51700200039			
			•						51700200020			
				•					51700200100			
					•				51700200048			
						•			51700200182			
							•		51700200057			
								•	51700200146			
4	• x3	• x4	• x5	• x6	• x7	• x7	• x8	• x8	54200100135	Corpo guida molla	Spring guide body	
5	• x3	• x4	• x5	• x6	• x7	• x7	• x8	• x8	51200400153	Molla conica	Tapered spring	
6	• x6	• x8	• x10	• x12	• x14	• x14	• x16	• x16	51000900116	Sfera grano 7/16"	Ball 7/16"	
7	• x3	• x4	• x5	• x6	• x7	• x7	• x8	• x8	54000000149	Tappo valvola mandata	Plug delivery valve	
8	• x3	• x4	• x5	• x6	• x7	• x7	• x8	• x8	51200501946	Molla ritorno pistone	Back piston spring	
9	• x3	• x4	• x5	• x6	• x7	• x7	• x8	• x8	53000000159	Distanziale	Spacer	
10	• x3	• x4	• x5	• x6	• x7	• x7	• x8	• x8	55000100209	Part. arresto sfera pompanti	Spacer sprine guide	
11	• x3	• x4	• x5	• x6	• x7		• x8		53200400026	Pistone pompante ø21	Pump piston ø21	
						• x7		• x8	53200400035	Pistone pompante ø22	Pump piston ø22	
12	•	•	•	•	•	•	•	•	53300400051	Boccola 34x30x30	Bushing 34x30x30	1
13	•	•	•	•	•	•	•	•	50100000187	Anello elastico	Circlip	1
14	•	•	•	•	•	•	•	•	51000600379	Ralla 93x44x10.4	Bearing 93x44x10.4	1
15	•	•	•	•	•	•	•	•	53300400159	Boccola 40x44x12	Bushing 40x44x12	1
16	•	•	•	•	•	•	•	•	51000655909	Gabbia assiale rulli 92x55x11	Axial roller cage 92x55x11	2
17	•	•	•	•	•	•	•	•	51000600431	Ralla 88x55x4	Bearing 88x55x4	3
18	•	•	•	•	•	•	•	•	52200500124	Albero	Shaft	1
19	•	•	•	•	•	•	•	•	51000100212	Cuscinetto sfere 62x30x16	Ball bearing 62x30x16	1
20	•	•	•	•	•	•	•	•	50600700313	Paraolio	Oil seal	1
21	•	•	•	•	•	•	•	•	50600200630	Guarnizione OR	O-Ring	1
22	•	•	•	•	•	•	•	•	51700200324	Corpo anteriore	Front housing	1
23	•	•	•	•	•	•	•	•	50200001120	Vite TCE M6x8	Socket head capscrew M6x8	2
24	•	•	•	•	•	•	•	•	11600901022	Rondella rame 10x6x1	Washer	2
25	•	•	•	•	•	•	•	•	50700000434	Guarnizione	Gasket	1

pag. 5

O.M.F.B. S.p.A. Hydraulic Components

We reserve the right to make any changes without notice.

Edition 2016.06 No reproduction, however partial, is permitted.

Via Cove, 719 25050 Povoaglio di Isèo (Brescia) Italy Tel.: +39 030 9830611
Fax: +39 030 9839207 208 Internet: www.omfb.it e-mail: conatti@omfb.itCOMPANY WITH
QUALITY SYSTEM
CERTIFIED BY DNV GL
= IATF 16949 =

PORTATA
FLOW

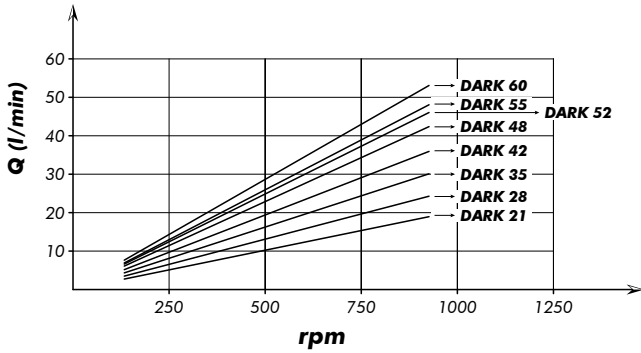

COPPIA ASSORBITA
DRIVE TORQUE

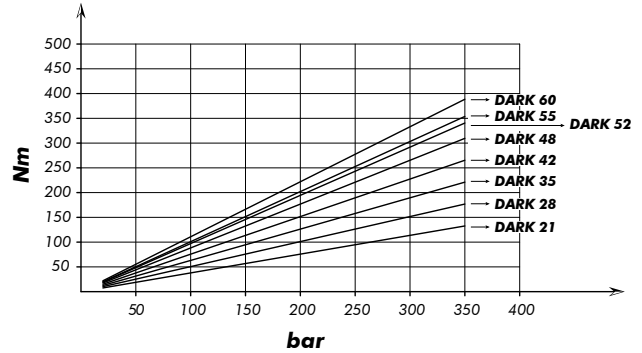

POTENZA ASSORBITA
POWER INPUT

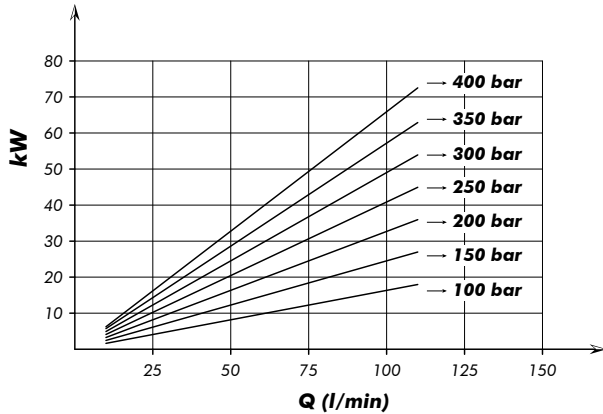

MOMENTO PESO / MASS MOMENT

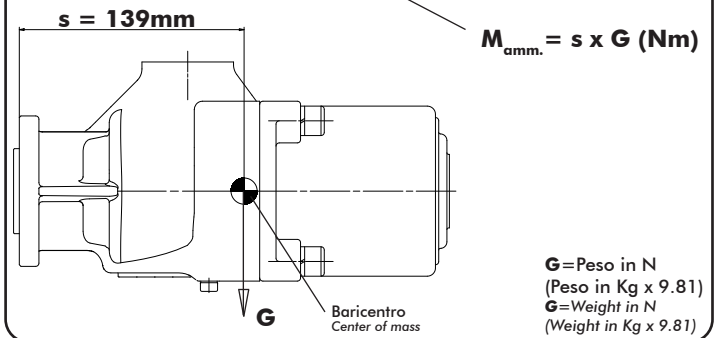

La quota "s" può essere considerata unica per tutte le cilindrata.
"s" dimension can be considered valid for all pump displacement.

Kit guarnizioni
Seal Kit

10890300018

99740060010

07/11/2019

99710800510 Rev: AG

POMPE A PISTONI FISSAGGIO 4 FORI-ISO

CODICE FAMIGLIA
FAMILY CODE

108005

4 HOLES-ISO HYDRAULIC PISTON PUMPS

"DARK" ISO

99740060010

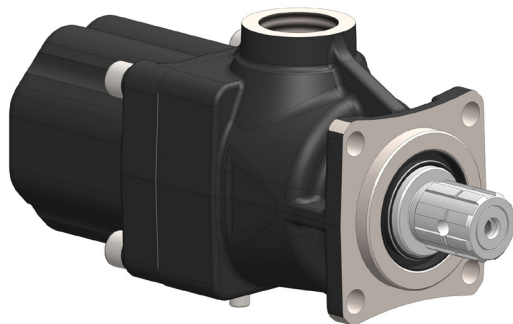

Fluido idraulico Fluid	Minerale o sintetico compatibile con guarnizioni: Mineral or synthetic compatible with the following seals: NBR, FKM, FPM, Nylon				
Viscosità cinematica consigliata Kinematic viscosity suggested	T media ambiente (°C) Average ambient temp. (°C)	< -10	-10 ÷ 10	10 ÷ 35	> 35
	VG (cSt = mm ² /s)	16	22	32	46
Viscosità cinematica ottimale di esercizio Optimale kinematic viscosity		VG= 10 cSt ÷ 100 cSt			
Viscosità cinematica max consentita all'avviamento Max kinematic viscosity suggested at the start-up		VG= 750 cSt			
Indice di viscosità consigliato Viscosity index suggested		VI > 100		Temperatura di esercizio Working temperature	
				-15°C ÷ 100°C	
Grado di filtrazione Oil filtering		> 200 bar: 10 µm < 200 bar: 25 µm			
Pres. di aspirazione Inlet pressure		0,85 ÷ 2 bar assoluti/absolut			
Senso di rotazione Pump rotation		Bidirezionale Bidirectional			
Verificare che la pompa sia posizionata almeno 100 mm sotto il livello minimo del serbatoio olio. Prima di avviare la pompa effettuare spurgo aria. Verify that pump is, at least, 100 mm under the minimum level of the tank. Before starting the pump bleed the air.					

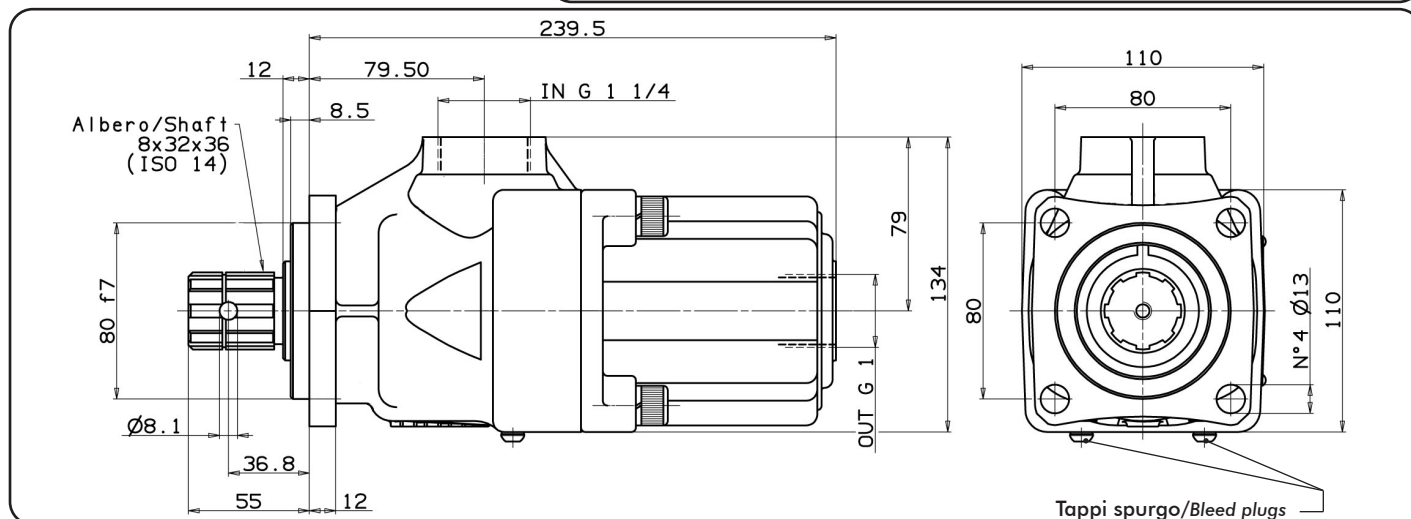

07/11/2019

99710800520 Rev: AH

Tipo pompa Pump type	Codice Code	Cilindrata Displacement cm ³ /rev	Pressione Pressure		Velocità massima Max speed rpm	Peso Weight kg
			Massima Max bar	Picco Peak bar		
DARK-21	10800502120	20,25	350	400	1800	14,8
DARK-28	10800502826	27				14,5
DARK-35	10800503521	33,75				14,4
DARK-42	10800504226	40,5				14,4
DARK-48	10800504824	47,25				14,2
DARK-52	10800505225	51,97				14,2
DARK-55	10800505529	54	300	350	1500	14,2
DARK-60	10800505921	59,3				14,2

pag.7

O.M.F.B. S.p.A. Hydraulic Components

We reserve the right to make any changes without notice.

Edition 2016.06 No reproduction, however partial, is permitted.

Via Cave, 7/9 25050 Provaglio d'Iseo (Brescia) Italy Tel.: +39.030.9830611
Fax: +39.030.9839207-208 Internet:www.omfb.it e-mail:contatti@omfb.it

COMPANY WITH
QUALITY SYSTEM
CERTIFIED BY DNV GL
= IATF 16949 =



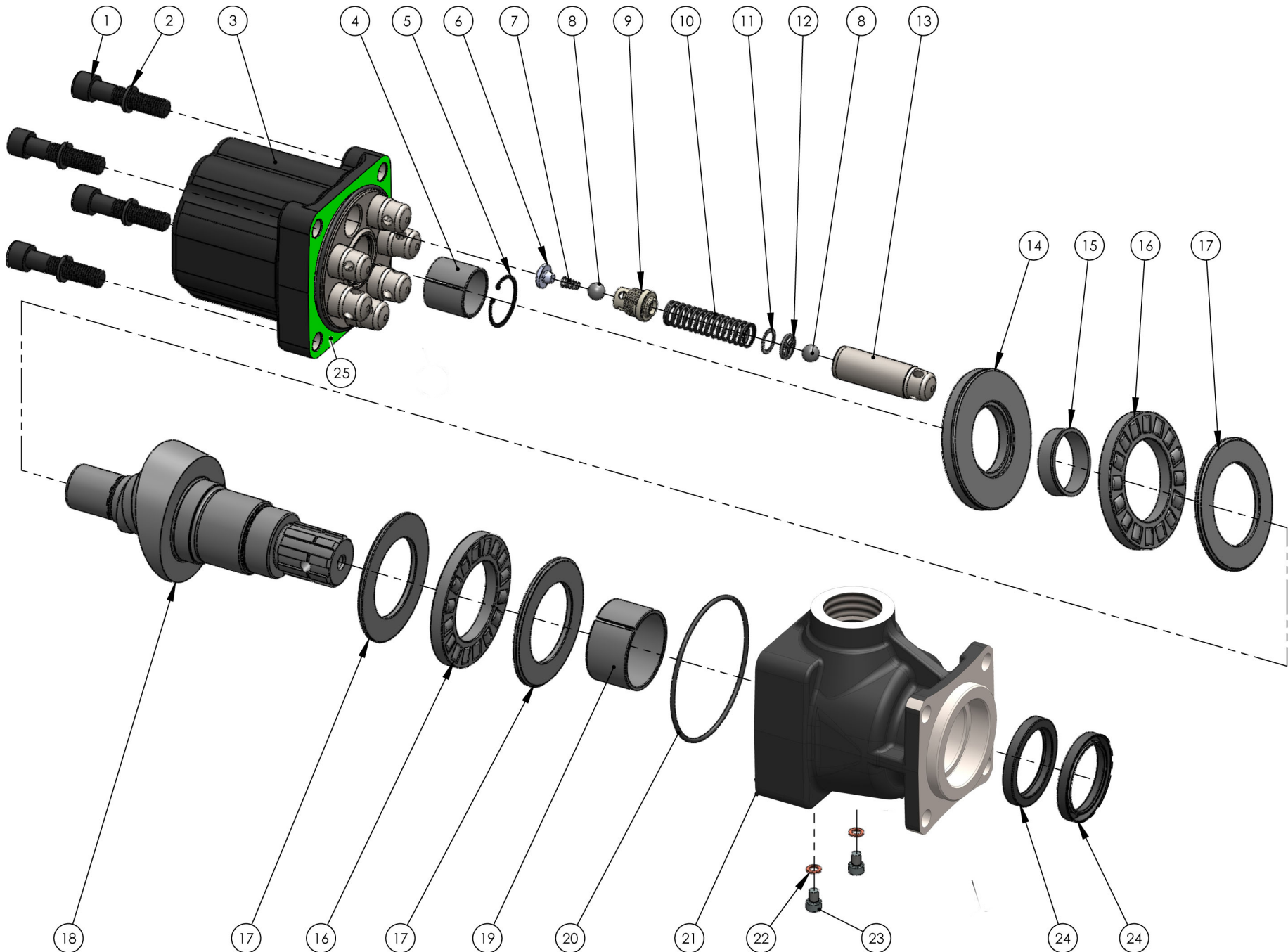

pag. 8

COMPANY WITH
QUALITY SYSTEM
CERTIFIED BY DNV GL
= IATF 16949 =

O.M.F.B. S.p.A. Hydraulic Components
We reserve the right to make any changes without notice.
Edition 2016.06 No reproduction, however partial, is permitted.
Via Cave, 7/9 25050 Proseggio d'Isco (Brescia) Italy Tel.: +39 030.9830611
Fax: +39 030.9839207-208 Internet: www.omfb.it e-mail:contatti@omfb.it





N°	21	28	35	42	48	52	55	60	Codice/P. Number	Descrizione / Description	Q.	
1	•	•	•	•	•	•	•	•	50200500591	Vite TCE M12x55 UNI 5931	Socket head capscrew	4
2	•	•	•	•	•	•	•	•	50100800063	Rondella elastica	Washer	4
3	•								51700200011	Corpo posteriore	Rear body	1
		•							51700200039			
			•						51700200020			
				•					51700200100			
					•				51700200048			
						•			51700200182			
							•		51700200057			
								•	51700200146			
4	•	•	•	•	•	•	•	•	53300400051	Boccola 34x30x30	Bushing 34x30x30	1
5	•	•	•	•	•	•	•	•	50100000187	Anello elastico	Circlip	1
6	• x3	• x4	• x5	• x6	• x7	• x7	• x8	• x8	54200100135	Corpo guida molla	Spring guide body	
7	• x3	• x4	• x5	• x6	• x7	• x7	• x8	• x8	51200400153	Molla conica	Tapered spring	
8	• x6	• x8	• x10	• x12	• x14	• x14	• x16	• x16	51000900116	Sfera grano 7/16"	Ball 7/16"	
9	• x3	• x4	• x5	• x6	• x7	• x7	• x8	• x8	54000000149	Tappo valvola mandata	Plug delivery valve	
10	• x3	• x4	• x5	• x6	• x7	• x7	• x8	• x8	51200501946	Molla ritorno pistone	Back piston spring	
11	• x3	• x4	• x5	• x6	• x7	• x7	• x8	• x8	53000000159	Distanziale	Spacer	
12	• x3	• x4	• x5	• x6	• x7	• x7	• x8	• x8	55000100209	Part. arresto sfera pompanti	Spacer sprine guide	
13	• x3	• x4	• x5	• x6	• x7		• x8		53200400026	Pistone pompante ø21	Pump piston ø21	
						• x7		• x8	53200400035	Pistone pompante ø22	Pump piston ø22	
14	•	•	•	•	•	•	•	•	51000600379	Ralla 93x44x10.4	Bearing 93x44x10.4	1
15	•	•	•	•	•	•	•	•	53300400159	Boccola 40x44x12	Bushing 40x44x12	1
16	•	•	•	•	•	•	•	•	51000655909	Gabbia assiale rulli 92x55x11	Axial roller cage 92x55x11	2
17	•	•	•	•	•	•	•	•	51000600431	Ralla 88x55x4	Bearing 88x55x4	3
18	•	•	•	•	•	•	•	•	52200500115	Albero	Shaft	1
19	•	•	•	•	•	•	•	•	53300400168	Boccola 55x50x30	Bushing 55x50x30	1
20	•	•	•	•	•	•	•	•	50600200630	Guarnizione OR	O-Ring	1
21	•	•	•	•	•	•	•	•	51700200315	Corpo anteriore	Front housing	1
22	•	•	•	•	•	•	•	•	11600901022	Rondella rame 10x6x1	Washer	2
23	•	•	•	•	•	•	•	•	50200001120	Vite TCE M6x8	Socket head capscrew	2
24	•	•	•	•	•	•	•	•	50600700706	Paraolio	Oil seal	2
25	•	•	•	•	•	•	•	•	50700000434	Guarnizione	Gasket	1

pag. 9

O.M.F.B. S.p.A. Hydraulic Components

We reserve the right to make any changes without notice.

Edition 2016.06 No reproduction, however partial, is permitted.

Via Cove, 719 25050 Povungolo d'Isèo (Brescia) Italy Tel.: +39 030 9830611
Fax: +39 030 9839207 208 Internet: www.omfb.it e-mail: com@omfb.itCOMPANY WITH
QUALITY SYSTEM
CERTIFIED BY DNV GL
= IATF 16949 =

PORTATA
FLOW

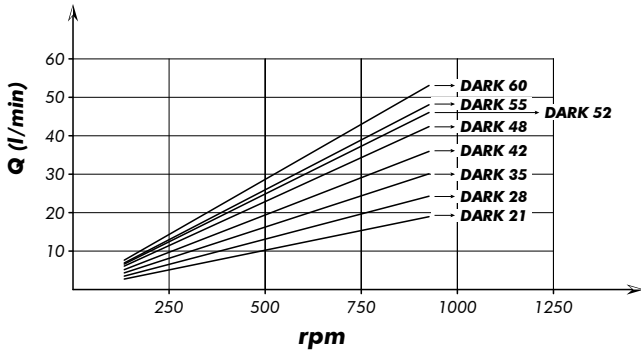

COPPIA ASSORBITA
DRIVE TORQUE

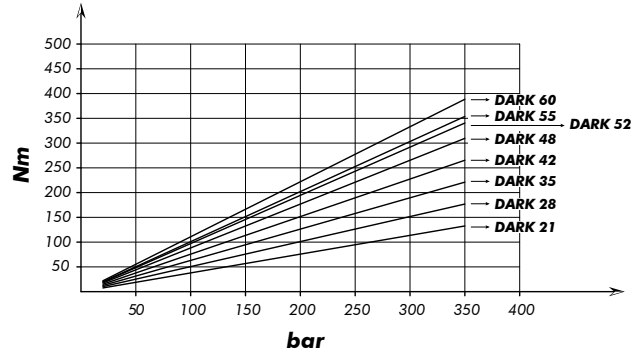

POTENZA ASSORBITA
POWER INPUT

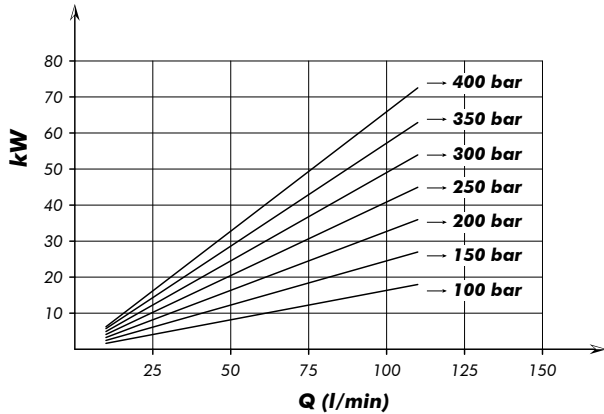

MOMENTO PESO / MASS MOMENT

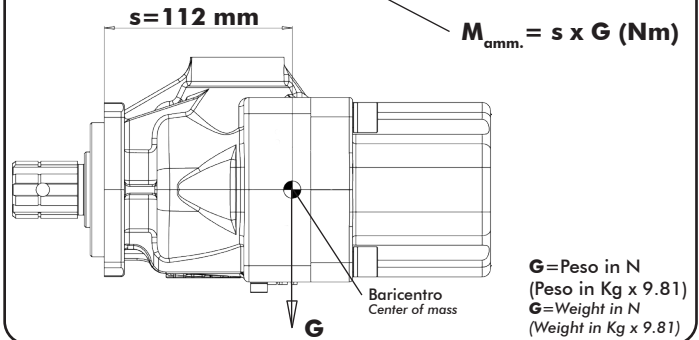

La quota "s" può essere considerata unica per tutte le cilindrate.
"s" dimension can be considered valid for all pump displacement.

Kit guarnizioni
Seal Kit

10890300027

99740060010

07/11/2019

99710800520 Rev: AH

**POMPE A PISTONI FISSAGGIO
4 FORI-ISO SHORT ALTA EFFICIENZA
HIGH EFFICIENCY 4 HOLES-ISO SHORT
HYDRAULIC PISTON PUMPS**

CODICE FAMIGLIA
FAMILY CODE

108009

"DARK" ISO SHORT HE

Le pompe a pistoni della serie HE offrono una maggiore capacità di aspirazione ad un basso regime di giri. Si rendono pertanto particolarmente idonee per tutte quelle applicazioni idrauliche dove sono richieste alte prestazioni abbinate a velocità di rotazione ridotte.
The piston pumps series HE offer enhanced suction ability at low RPM range. Thus, these pumps are particularly suitable for all those hydraulic applications requiring high performance at low rotation speed.

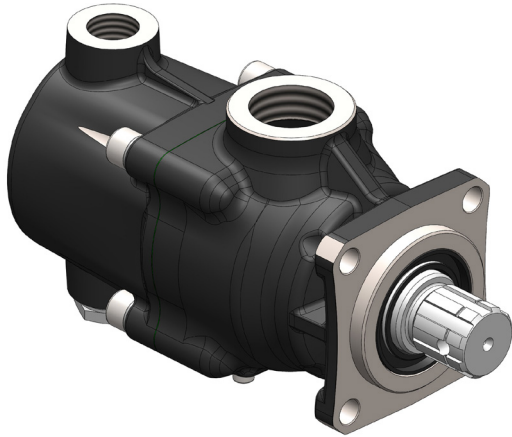

Fluido idraulico Fluid	Minerale o sintetico compatibile con guarnizioni: Mineral or synthetic compatible with the following seals: NBR, FKM, FPM, Nylon				
Viscosità cinematica consigliata Kinematic viscosity suggested	T media ambiente (°C) Average ambient temp. (°C)	< -10	-10÷10	10÷35	> 35
	VG (cSt = mm ² /s)	16	22	32	46
Viscosità cinematica ottimale di esercizio Optimale kinematic viscosity			VG= 10 cSt ÷ 100 cSt		
Viscosità cinematica max consentita all'avviamento Max kinematic viscosity suggested at the start-up			VG= 750 cSt		
Indice di viscosità consigliato Viscosity index suggested	VI > 100	Temperatura di esercizio Working temperature -40°C ÷ 140°C			
Grado di filtrazione Oil filtering		> 200 bar: 10 µm < 200 bar: 25 µm			
Pres. di aspirazione / Inlet pressure		0,85 ÷ 2 bar assoluti/absolut			
Senso di rotazione / Pump rotation		Bidirezionale / Bidirectional			
Verificare che la pompa sia posizionata almeno 100 mm sotto il livello minimo del serbatoio olio. Prima di avviare la pompa effettuare spurgo aria. Verify that pump is, at least, 100 mm under the minimum level of the tank. Before starting the pump bleed the air.					

99740060010

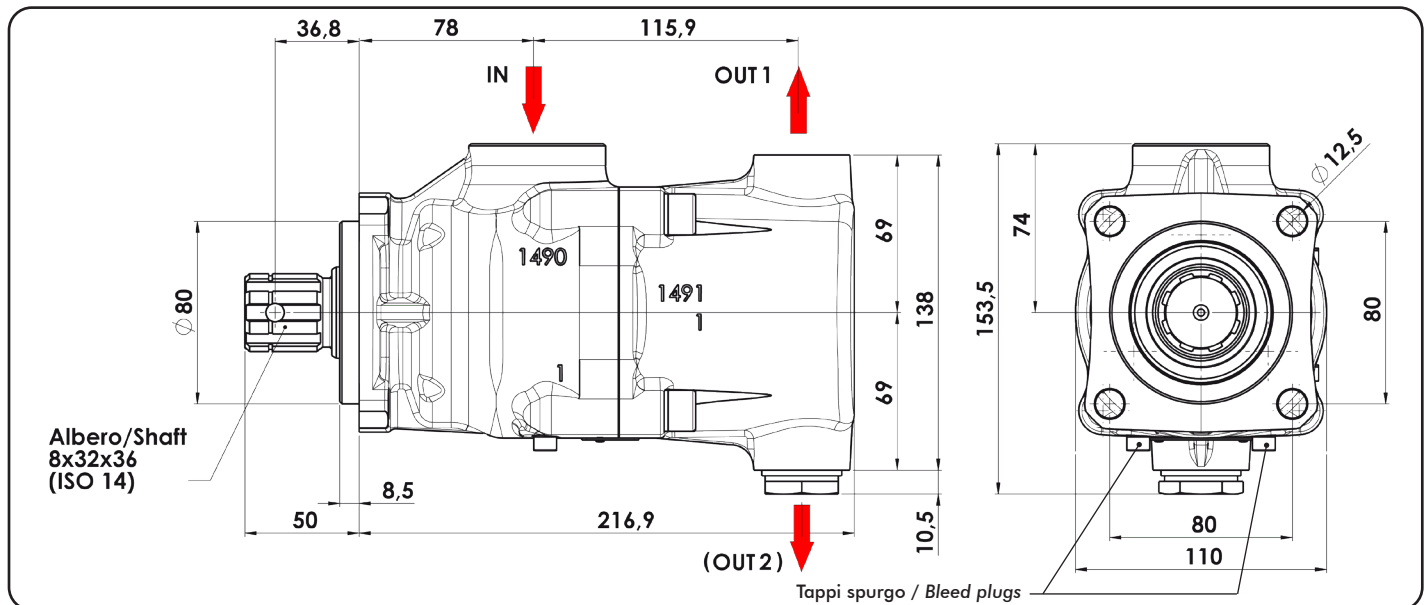

Tipo pompa Pump type	Codice Code	Cilindrata Displacement cm ³ /rev	IN GAS	OUT GAS	IN METRICO	OUT METRICO	Pressione/Pressure		Velocità massima Max speed	Peso Weight kg																
							Max.	Picco/Peak																		
DARK SHORT-21	10800902126	20,25	G 1-1/4	G 3/4	M45x2	M22x1,5	350 bar	400 bar	1800 rpm	13,2																
	10800932120																									
DARK SHORT-28	10800902822	27	G 1-1/4	G 3/4	M45x2	M22x1,5					350 bar	400 bar	1800 rpm	13,2												
	10800932826																									
DARK SHORT-35	10800903527	33,75	G 1-1/4	G 3/4	M45x2	M22x1,5									350 bar	400 bar	1800 rpm	13,1								
	10800933521																									
DARK SHORT-42	10800904222	40,5	G 1-1/4	G 3/4	M45x2	M22x1,5													350 bar	400 bar	1800 rpm	13				
	10800934226																									
DARK SHORT-48	10800904820	47,25	G 1-1/4	G 3/4	M45x2	M22x1,5																	350 bar	400 bar	1800 rpm	12,9
	10800934824																									
DARK SHORT-52	10800905221	51,97	G 1-1/4	G 3/4	M45x2	M22x1,5	350 bar	400 bar	1800 rpm	13																
	10800935225																									
DARK SHORT-55	10800905525	54	G 1-1/4	G 3/4	M45x2	M22x1,5					300 bar	350 bar	1500 rpm	12,9												
	10800935529																									
DARK SHORT-60	10800906024	59,3	G 1-1/4	G 3/4	M45x2	M22x1,5									300 bar	350 bar	1500 rpm	12,8								
	10800936028																									

05/01/2021

99710800901 Rev: AB

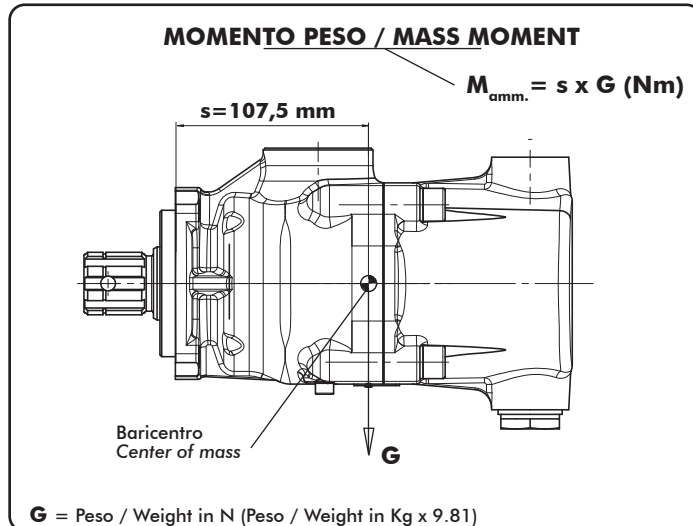
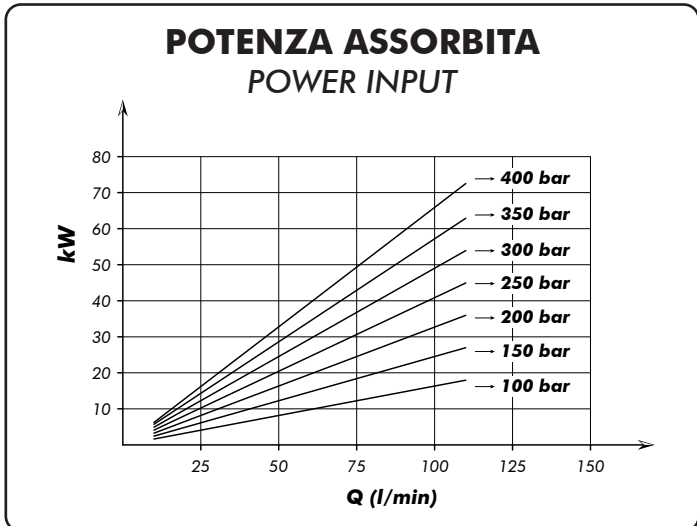
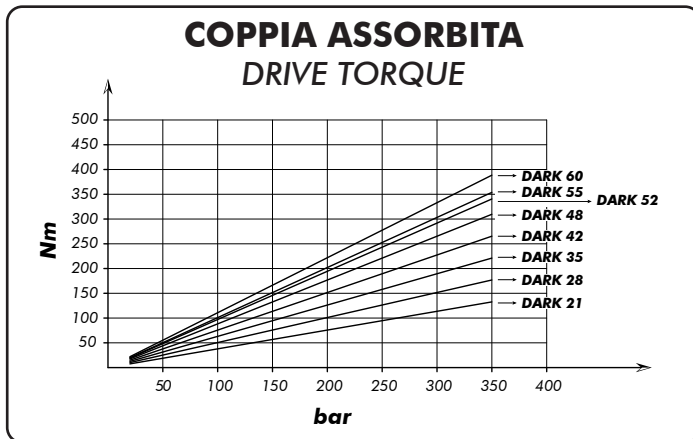
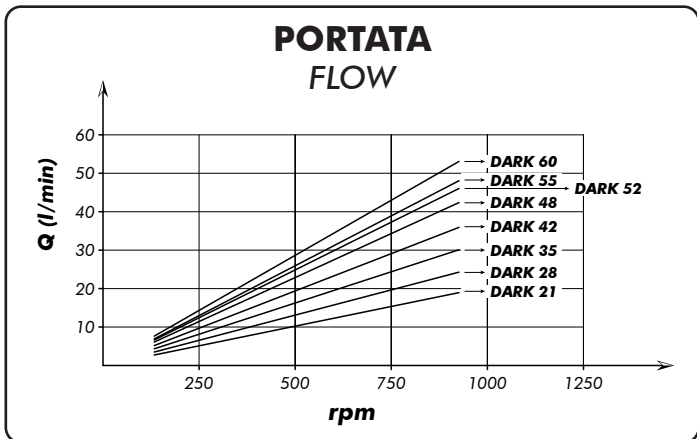

Kit guarnizioni / Seal Kit
10890300063

"s" la dimensione può essere considerata valida per tutte le pompe
dimension can be considered valid for all pump displacement

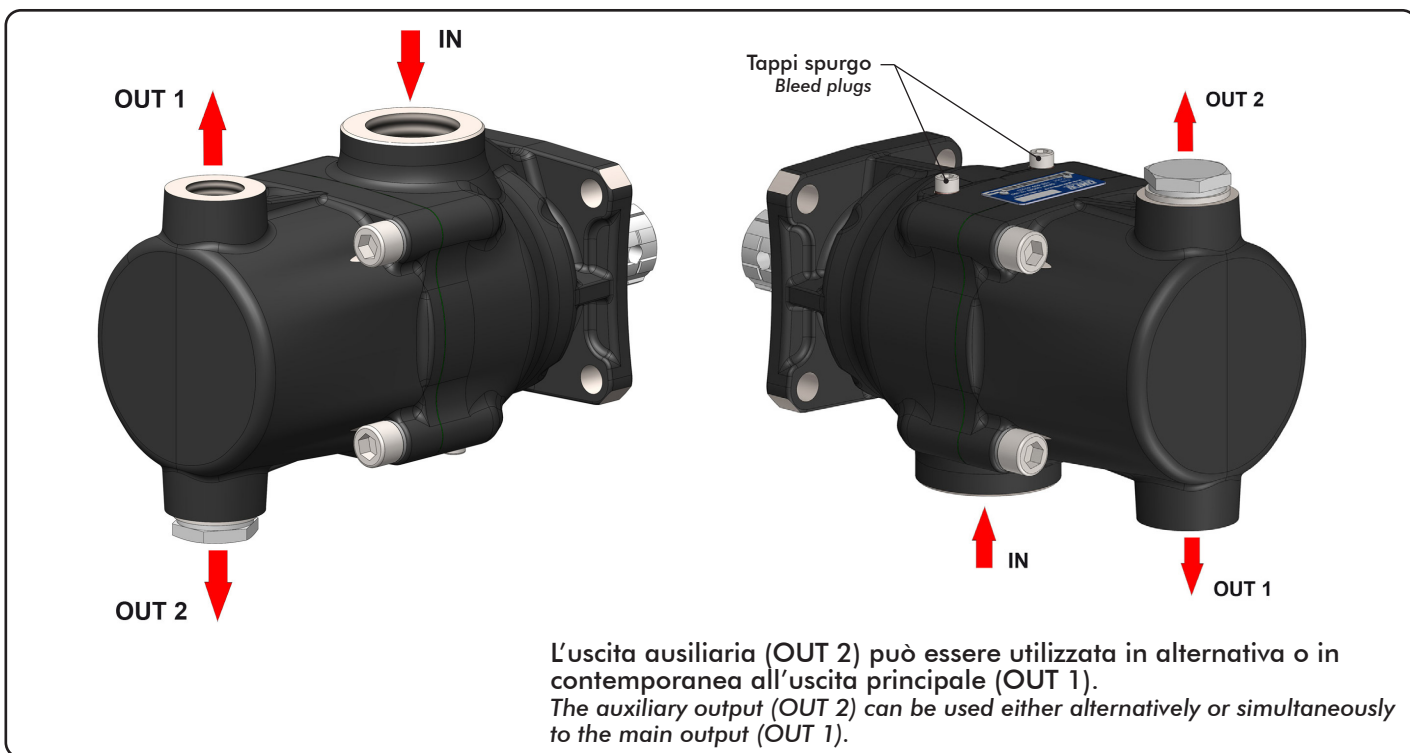

POMPE A PISTONI ASSIALI AXIAL HYDRAULIC PISTON PUMPS

CODICE FAMIGLIA
FAMILY CODE

108007

"DARK" SAE-B

99740060010

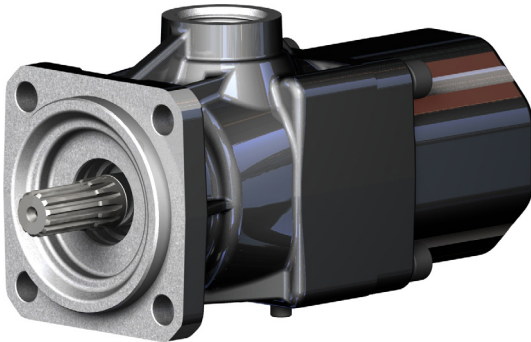

Fluido idraulico Fluid	Minerale o sintetico compatibile con guarnizioni: Mineral or synthetic compatible with the following seals: NBR, FKM, FPM, Nylon				
Viscosità cinematica consigliata Kinematic viscosity suggested	T media ambiente (°C) Average ambient temp. (°C)	< -10	-10 ÷ 10	10 ÷ 35	> 35
	VG (cSt = mm ² /s)	16	22	32	46
Viscosità cinematica ottimale di esercizio Optimale kinematic viscosity		VG= 10 cSt ÷ 100 cSt			
Viscosità cinematica max consentita all'avviamento Max kinematic viscosity suggested at the start-up		VG= 750 cSt			
Indice di viscosità consigliato Viscosity index suggested		VI > 100		Temperatura di esercizio Working temperature	
				-15°C ÷ 100°C	
Grado di filtrazione Oil filtering		> 200 bar: 10 µm < 200 bar: 25 µm			
Pres. di aspirazione Inlet pressure		0,85 ÷ 2 bar assoluti/absolut			
Senso di rotazione Pump rotation		Bidirezionale Bidirectional			
Verificare che la pompa sia posizionata almeno 100 mm sotto il livello minimo del serbatoio olio. Prima di avviare la pompa effettuare spurgo aria. Verify that pump is, at least, 100 mm under the minimum level of the tank. Before starting the pump bleed the air.					

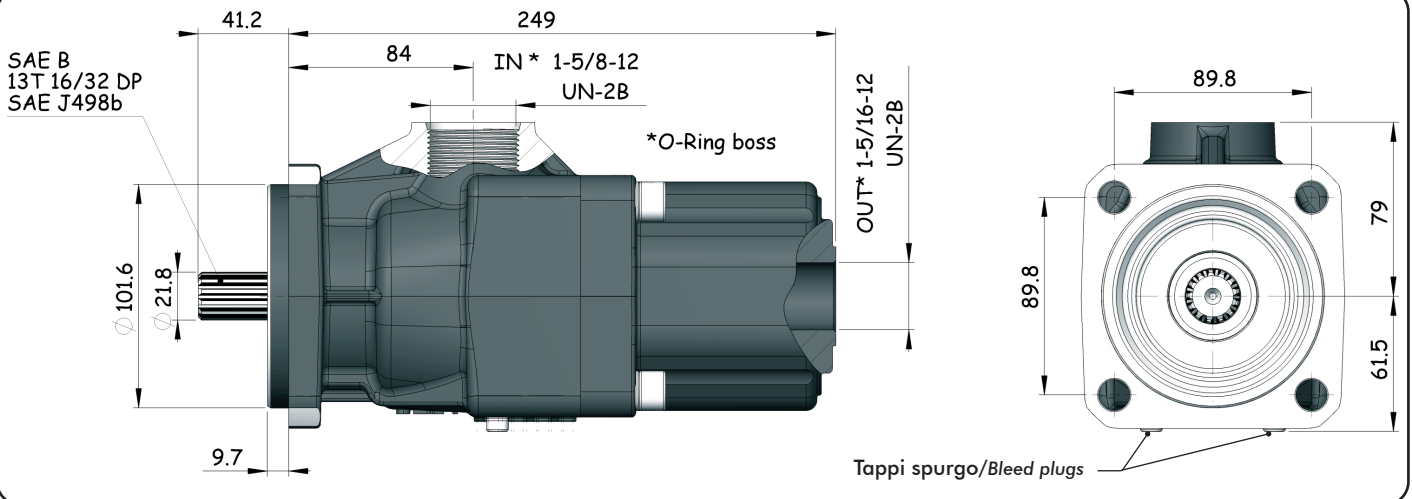

19/03/2013

99710800701 Rev. AC

Tipo pompa Pump type	Codice Code	Cilindrata Displacement cm ³ /rev	Pressione Pressure		Velocità max Max speed rpm	Peso Weight kg
			Massima Max bar	Picco Peak bar		
DARK SAE-B 21	10800700219	20,25	350		1800	15,4
DARK SAE-B 28	10800700282	27				15,2
DARK SAE-B 35	10800700353	33,75				15,2
DARK SAE-B 42	10800700424	40,5				15,2
DARK SAE-B 48	10800700488	47,25	340		1500	15
DARK SAE-B 52	10800700522	51,97	310	15		
DARK SAE-B 55	10800700559	54	300	15,1		
DARK SAE-B 60	10800700602	59,3	270	14,9		

pag.13



O.M.F.B. S.p.A. Hydraulic Components
We reserve the right to make any changes without notice.
Edition 2016.06 No reproduction, however partial, is permitted.
Via Cave, 7/9 25050 Provaglio d'Iseo (Brescia) Italy Tel.: +39.030.9830611
Fax: +39.030.9839207-208 Internet:www.omfb.it e-mail:contatti@omfb.it

COMPANY WITH
QUALITY SYSTEM
CERTIFIED BY DNV GL
= IATF 16949 =

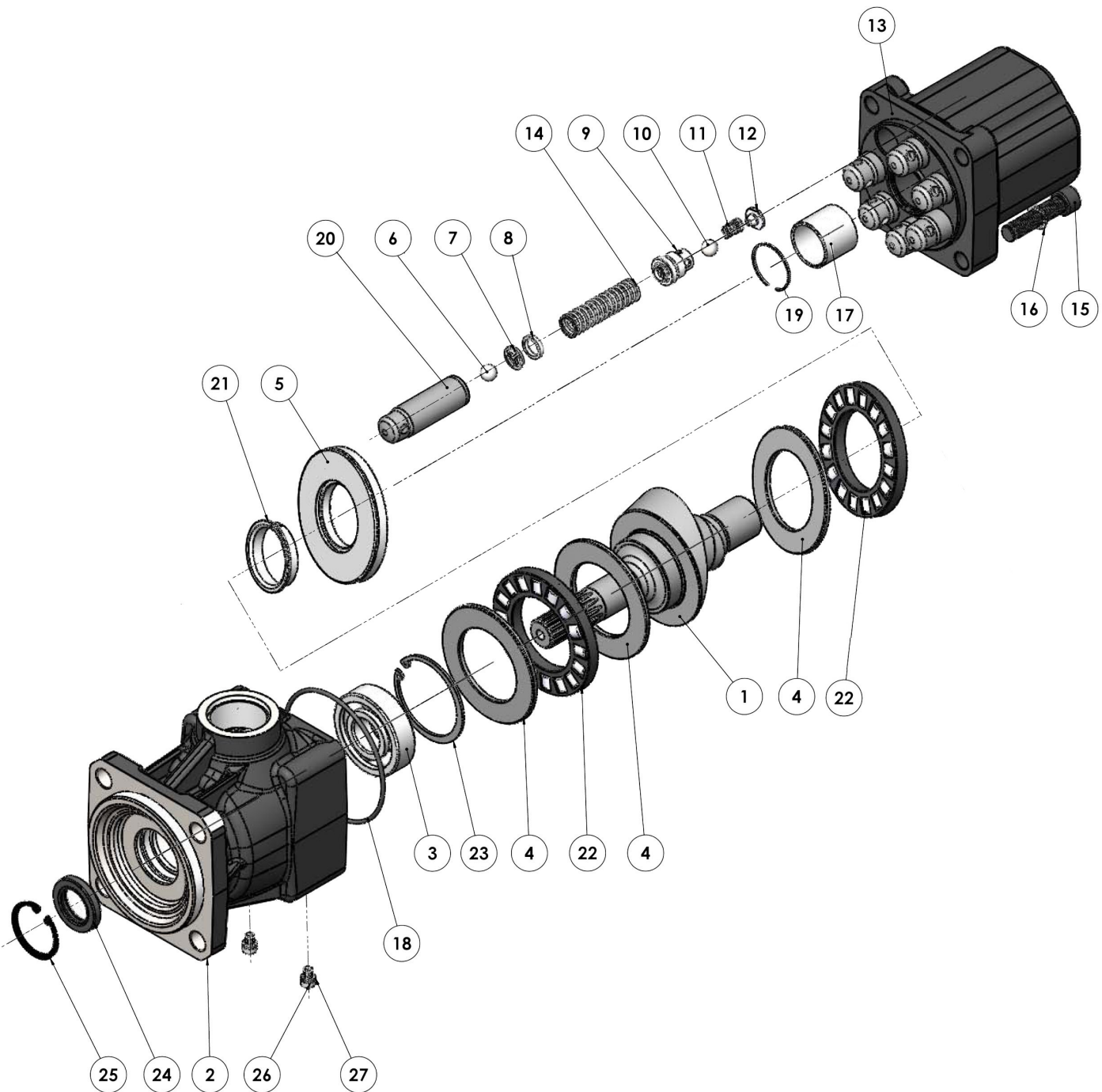

N° N°	21	28	35	42	48	52	55	60	Codice P. Number	Descrizione Description	Q.tà Q.ty	
1	•	•	•	•	•	•	•	•	52200500188	Albero	Shaft	1
2	•	•	•	•	•	•	•	•	51700200404	Corpo anteriore	Front housing	1
3	•	•	•	•	•	•	•	•	51000125624	Cuscinetto a sfere 25x62x17 CL.A	Ball bearing 25x62x17 CL.A	1
4	•	•	•	•	•	•	•	•	51000600431	Ralla 88x55x4	Bearing 88x55x4	3
5	•	•	•	•	•	•	•	•	51000600379	Ralla 93x44x10.4	Bearing 93x44x10.4	1
6	• x3	• x4	• x5	• x6	• x7	• x7	• x8	• x8	51000900116	Sfera grano AAA 7/16" (11.11)	Ball AAA 7/16" (11.11)	
7	• x3	• x4	• x5	• x6	• x7	• x7	• x8	• x8	55000100209	Part. arresto sfera pompanti	Spacer sprine guide	
8	• x3	• x4	• x5	• x6	• x7	• x7	• x8	• x8	53000000159	Distanziale	Spacer	
9	• x3	• x4	• x5	• x6	• x7	• x7	• x8	• x8	54000000149	Tappo valvola mandata	Plug delivery valve	
10	• x3	• x4	• x5	• x6	• x7	• x7	• x8	• x8	51000900116	Sfera grano AAA 7/16" (11.11)	Ball AAA 7/16" (11.11)	
11	• x3	• x4	• x5	• x6	• x7	• x7	• x8	• x8	51200400153	Molla conica	Tapered spring	
12	• x3	• x4	• x5	• x6	• x7	• x7	• x8	• x8	54200100135	Corpo guida molla	Spring guide body	
13	•								51700210215	Corpo posteriore	Rear body	1
		•							51700210288			
			•						51700210359			
				•					51700210420			
					•				51700210484			
						•			51700210528			
							•		51700210555			
							•	51700210608				
14	• x3	• x4	• x5	• x6	• x7	• x7	• x8	• x8	51200500581	Molla ritorno pistone	Back piston spring	
15	•	•	•	•	•	•	•	•	50200500591	Vite TCE M12x55 UNI 5931	Socket head capscrew	4
16	•	•	•	•	•	•	•	•	50100800063	Rondella elastica	Washer	4
17	•	•	•	•	•	•	•	•	53300400051	Boccola 34x30x30	Bushing 34x30x30	1
18	•	•	•	•	•	•	•	•	50600200630	Guarnizione OR	O-Ring	1
19	•	•	•	•	•	•	•	•	50100000187	Anello elastico E-SB 34	Circlip E-SB 34	1
20	• x3	• x4	• x5	• x6	• x7		• x8		53200400026	Pistone pompante ø21	Pump piston ø21	
						• x7		• x8	53200400035	Pistone pompante ø22	Pump piston ø22	
21	•	•	•	•	•	•	•	•	53300400159	Boccola 40x44x12	Bushing 40x44x12	1
22	•	•	•	•	•	•	•	•	51000655909	Gabbia assiale rulli 92x55x11	Axial roller cage 92x55x11	2
23	•	•	•	•	•	•	•	•	50100100588	Anello elastico Ø62l	Circlip Ø62l	1
24	•	•	•	•	•	•	•	•	50602425401	Guarnizione paraolio GAP 25x40x7	Gasket GAP 25x40x7	1
25	•	•	•	•	•	•	•	•	50100100373	Anello elastico Ø40l	Circlip Ø40l	1
26	•	•	•	•	•	•	•	•	50200001120	Vite TBCE M6x8	Socket head capscrew	2
27	•	•	•	•	•	•	•	•	11600900023	Rondella alluminio 10x6x1	Aluminium washer 10x6x1	2

pag. 15

O.M.F.B. S.p.A. Hydraulic Components

We reserve the right to make any changes without notice.

Edition 2016.06 No reproduction, however partial, is permitted.

Via Cave, 719 25050 Povoletto di Isèo (Brescia) Italy Tel.: +39 030 9830611
Fax: +39 030 9839207 208 Internet: www.omfb.it e-mail: contact@omfb.it

COMPANY WITH
QUALITY SYSTEM
CERTIFIED BY DNV GL
= IATF 16949 =

PORTATA
FLOW

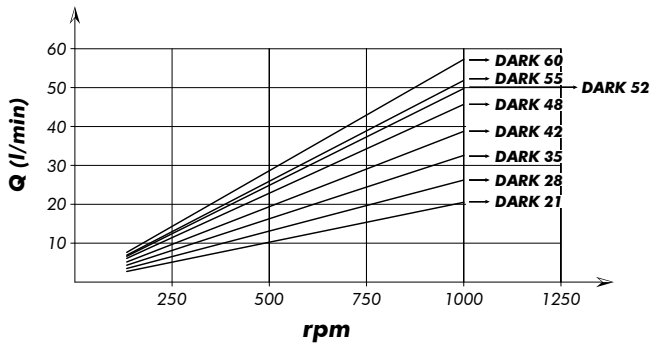

COPPIA ASSORBITA
DRIVE TORQUE

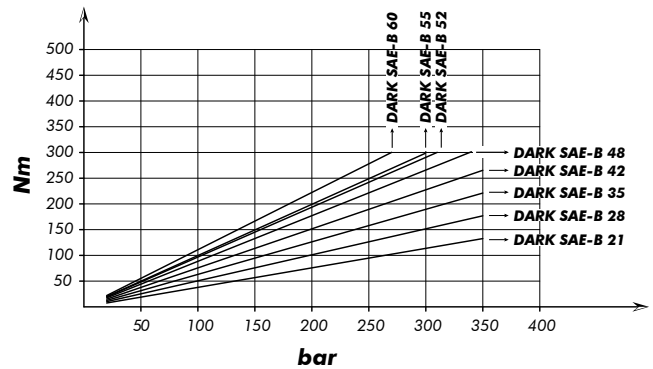

POTENZA ASSORBITA
POWER INPUT

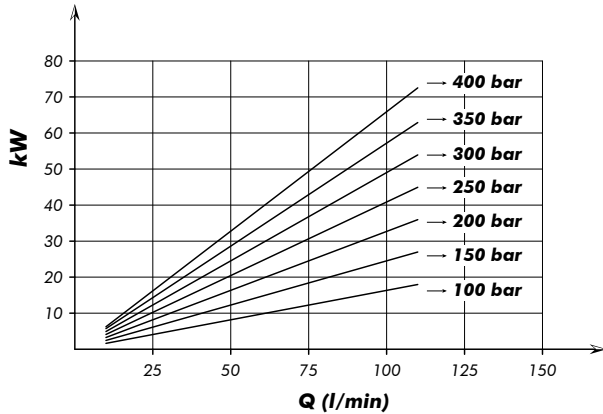

MOMENTO PESO / MASS MOMENT

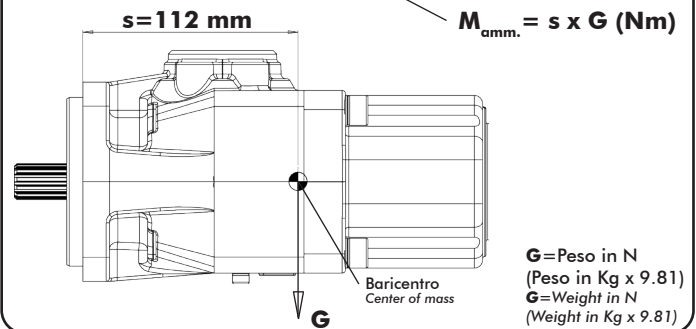

La quota "s" può essere considerata unica per tutte le cilindrate.
"s" dimension can be considered valid for all pump displacement.

Kit guarnizioni
Seal Kit

10890300054

99740060010

19/03/2013

99710800701 Rev: AC

POMPE A PISTONI FISSAGGIO 4 FORI-ISO

CODICE FAMIGLIA
FAMILY CODE

108005

4 HOLES-ISO HYDRAULIC PISTON PUMPS

"2PAK"

99740060010

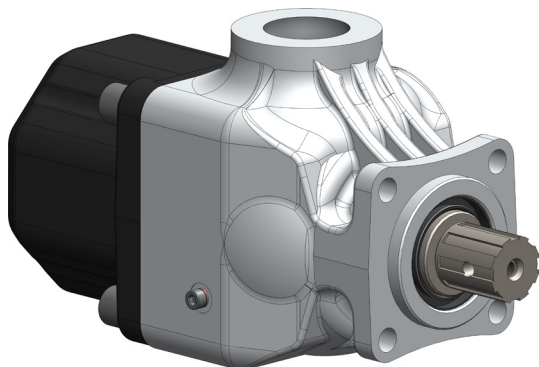

Fluido idraulico Fluid	Minerale o sintetico compatibile con guarnizioni: Mineral or synthetic compatible with the following seals: NBR, FKM, FPM, Nylon				
Viscosità cinematica consigliata Kinematic viscosity suggested	T media ambiente (°C) Average ambient temp. (°C)	< -10	-10 ÷ 10	10 ÷ 35	> 35
	VG (cSt = mm ² /s)	16	22	32	46
Viscosità cinematica ottimale di esercizio Optimale kinematic viscosity		VG = 10 cSt ÷ 100 cSt			
Viscosità cinematica max consentita all'avviamento Max kinematic viscosity suggested at the start-up		VG = 750 cSt			
Indice di viscosità consigliato Viscosity index suggested		VI > 100		Temperatura di esercizio Working temperature	
				-15°C ÷ 100°C	
Grado di filtrazione Oil filtering		> 200 bar: 10 µm < 200 bar: 25 µm			
Pres. di aspirazione Inlet pressure		0,85 ÷ 2 bar assoluti/absolut			
Senso di rotazione Pump rotation		Bidirezionale Bidirectional			
Verificare che la pompa sia posizionata almeno 100 mm sotto il livello minimo del serbatoio olio. Prima di avviare la pompa effettuare spurgo aria. Verify that pump is, at least, 100 mm under the minimum level of the tank. Before starting the pump bleed the air.					

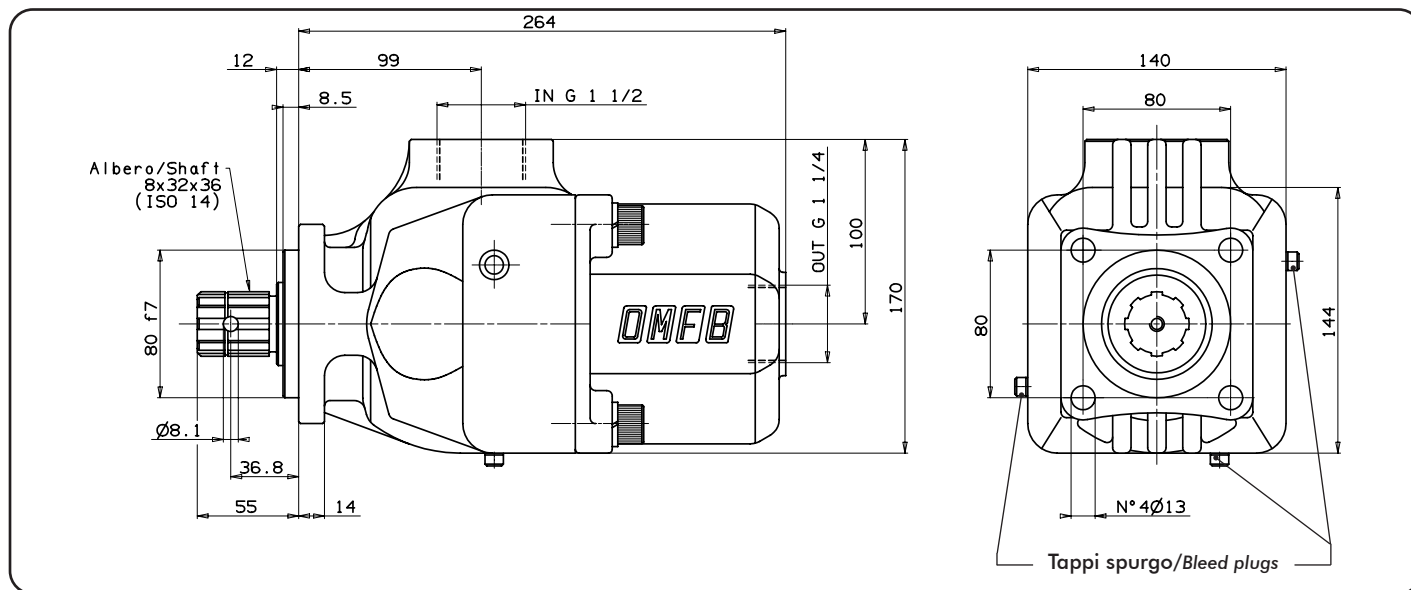

07/11/2019

99710800530 Rev. AG

Tipo pompa Pump type	Codice Code	Cilindrata Displacement	Pressione Pressure		Velocità massima Max speed	Peso Weight
			Massima Max	Picco Peak		
		cm ³ /rev	bar	bar	rpm	kg
2PAK-70	10800507027	73	300	350	1500	20.9
2PAK-80	10800508026	82,2				20.8
2PAK-90	10800509025	91,4				20,7
2PAK-100	10800510022	100,4				20,7

pag.17

O.M.F.B. S.p.A. Hydraulic Components

We reserve the right to make any changes without notice.

Edition 2016.06 No reproduction, however partial, is permitted.

Via Cave, 7/9 25050 Provaglio d'Iseo (Brescia) Italy Tel.: +39.030.9830611
Fax: +39.030.9839207-208 Internet:www.omfb.it e-mail:contatti@omfb.it

COMPANY WITH
QUALITY SYSTEM
CERTIFIED BY DNV GL
= IATF 16949 =



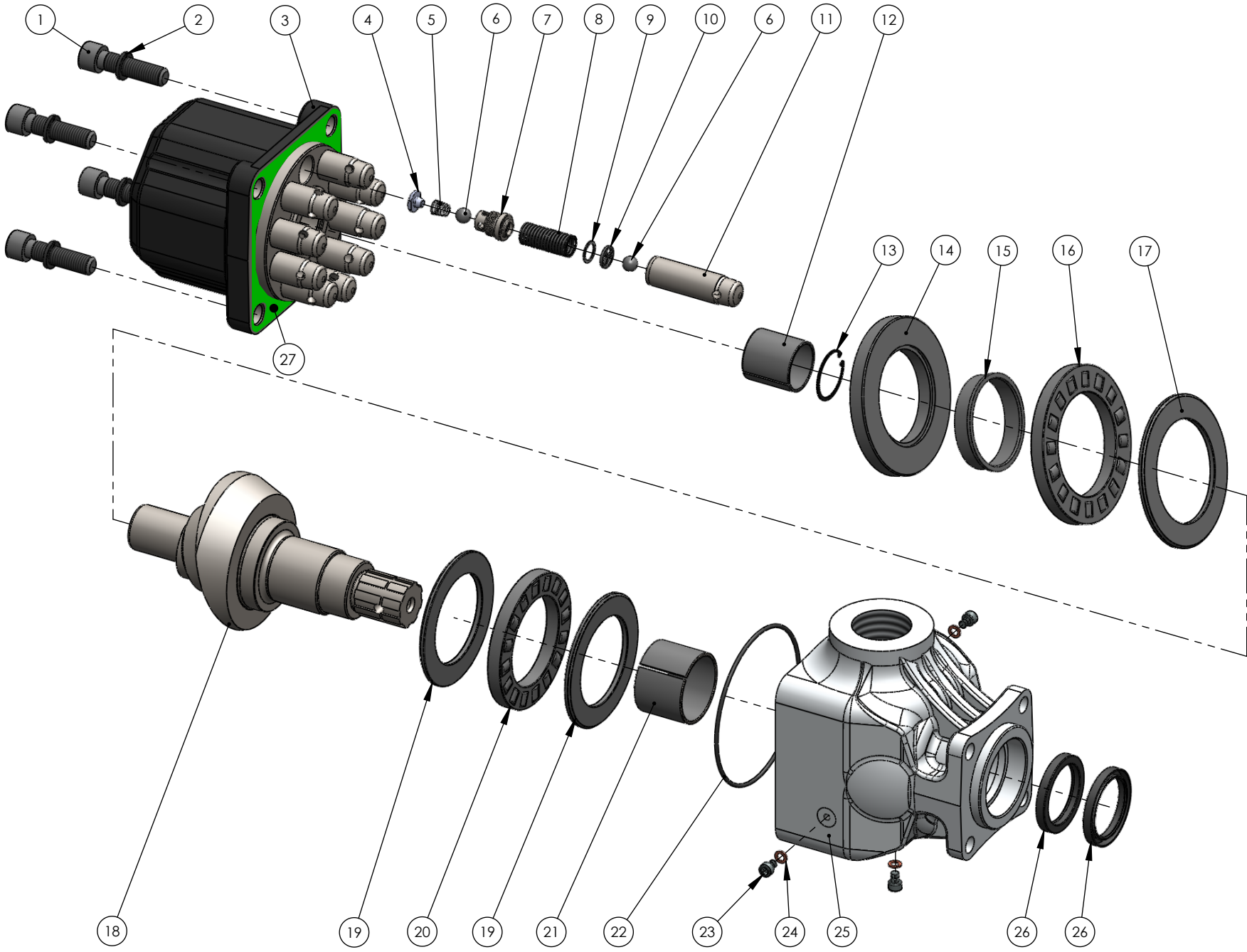

COMPANY WITH
QUALITY SYSTEM
CERTIFIED BY DNV GL
= IATF 16949 =

O.M.F.B. S.p.A. Hydraulic Components
We reserve the right to make any changes without notice.
Edition 2016.06 No reproduction, however partial, is permitted.
Via Cava, 7/9 25050 Proseggio d'Isco (Brescia) Italy Tel.: +39 030.9830611
Fax: +39 030.9839207-208 Internet: www.omfb.it e-mail: conatitf@omfb.it

pag. 18



N°	70	80	90	100	Codice/P. Number	Descrizione/Description	Q.	
1	•	•	•	•	50200600581	Vite TCE M14x55	Socket head capscrew	4
2	•	•	•	•	50100800072	Rondella elastica	Washer	4
3	•				51700200093	Corpo posteriore	Rear body	1
		•			51700200155			
			•		51700200173			
				•	51700200119			
4	• x8	• x9	• x10	• x10	54200100135	Corpo guida molla	Spring guide body	
5	• x8	• x9	• x10	• x10	51200400153	Molla conica	Tapered spring	
6	• x16	• x18	• x20	• x20	51000900116	Sfera grano 7/16"	Ball 7/16"	
7	• x8	• x9	• x10	• x10	54000000149	Tappo valvola mandata	Plug delivery valve	
8	• x8	• x9	• x10	• x10	51200501946	Molla ritorno pistone	Back piston spring	
9	• x8	• x9	• x10	• x10	53000000159	Distanziale	Spacer	
10	• x8	• x9	• x10	• x10	55000100209	Part. arresto sfera pompanti	Spacer sprine guide	
11	• x8	• x9	• x10		53200400044	Pistone pompante ø21	Pump piston ø21	
				• x10	53200400053	Pistone pompante ø22	Pump piston ø22	
12	•	•	•	•	53300400140	Boccola 35x39x40	Bushing 35x39x40	1
13	•	•	•	•	50100000196	Anello elastico	Circlip	1
14	•	•	•	•	51000600404	Ralla 70x119x12.5	Bearing 70x119x12.5	1
15	•	•	•	•	53300400257	Boccola 65x70x15	Bushing 65x70x15	1
16	•	•	•	•	51000680122	Gabbia assiale rulli 78x119x11	Axial roller cage 78x119x11	1
17	•	•	•	•	51000600397	Ralla 78x115x4.5	Bearing 78x115x4.5	1
18	•	•	•	•	52200500133	Albero	Shaft	1
19	•	•	•	•	51000600440	Ralla 70x104x4.5	Bearing 70x104x4.5	2
20	•	•	•	•	51000670106	Gabbia assiale rulli 70x106x11	Axial roller cage 70x106x11	1
21	•	•	•	•	53300400177	Boccola 50x55x40	Bushing 50x55x40	1
22	•	•	•	•	50600200676	Guarnizione OR	O-Ring	1
23	•	•	•	•	50200200405	Vite TCE M 6x10	Socket head capscrew	3
24	•	•	•	•	11600901022	Rondella in rame	Washer	3
25	•	•	•	•	51700200299	Corpo anteriore	Front housing	1
26	•	•	•	•	50600700706	Paraolio	Oil seal	2
27	•	•	•	•	50700000452	Guarnizione	Gasket	1

pag. 19



O.M.F.B. S.p.A. Hydraulic Components

We reserve the right to make any changes without notice.

Edition 2016.06 No reproduction, however partial, is permitted.

Via Cove, 719 25050 Povungio di/seo (Brescia) Italy. Tel.: +39 030 9830611
Fax: +39 030 9839207 208 Internet: www.omfb.it e-mail: conatti@omfb.itCOMPANY WITH
QUALITY SYSTEM
CERTIFIED BY DNV GL
= IATF 16949 =

PORTATA
FLOW

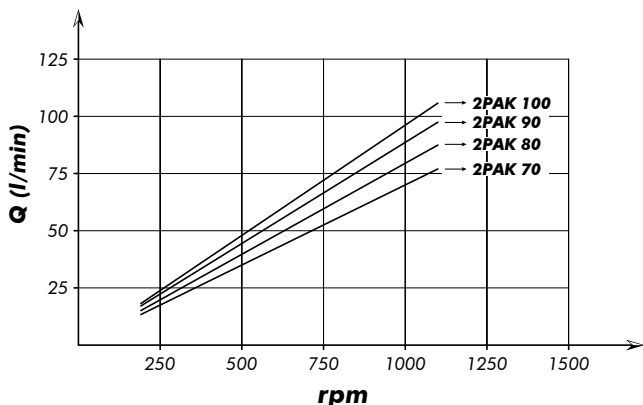

COPPIA ASSORBITA
DRIVE TORQUE

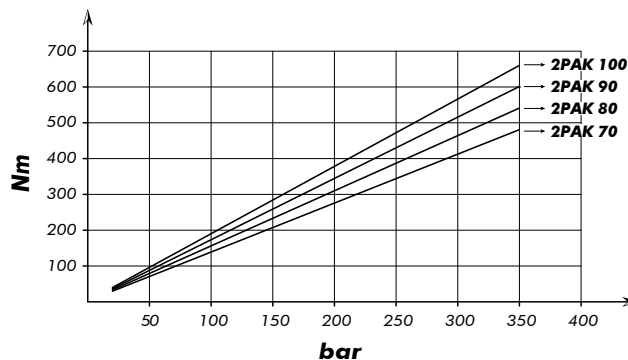

POTENZA ASSORBITA
POWER INPUT

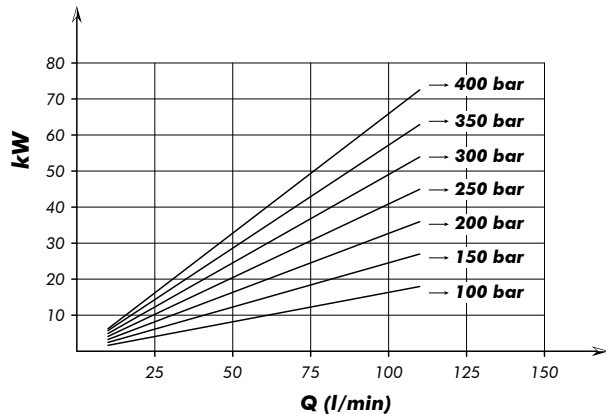

MOMENTO PESO / MASS MOMENT

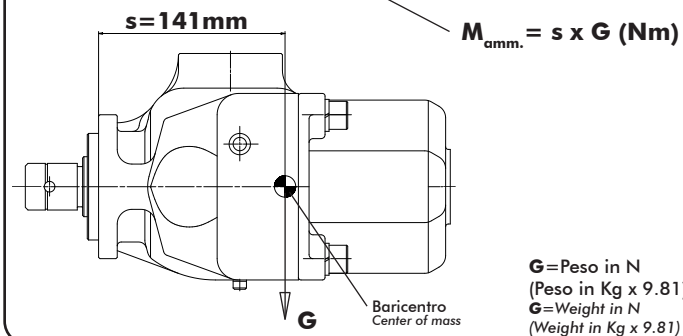

La quota "s" può essere considerata unica per tutte le cilindrata.
"s" dimension can be considered valid for all pump displacement.

Kit guarnizioni
Seal Kit

10890300036

99740060010

07/11/2019

99710800530 Rev: AG

POMPE A PISTONI FISSAGGIO 4 FORI-ISO DOPPIA MANDATA

CODICE FAMIGLIA
FAMILY CODE

108008

TWIN DELIVERY 4 HOLES-ISO
HYDRAULIC PISTON PUMPS

"2PAK"

99740060010

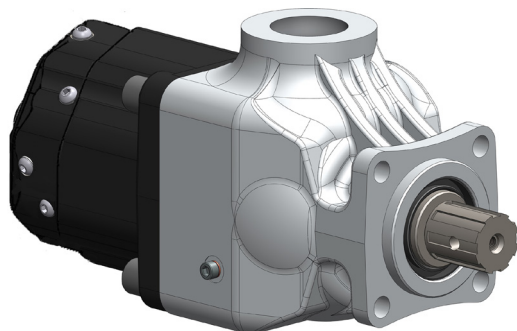

Fluido idraulico Fluid	Minerale o sintetico compatibile con guarnizioni: Mineral or synthetic compatible with the following seals: NBR, FKM, FPM, Nylon				
Viscosità cinematica consigliata Kinematic viscosity suggested	T media ambiente (°C) Average ambient temp. (°C)	< -10	-10 ÷ 10	10 ÷ 35	> 35
	VG (cSt = mm ² /s)	16	22	32	46
Viscosità cinematica ottimale di esercizio Optimale kinematic viscosity		VG= 10 cSt ÷ 100 cSt			
Viscosità cinematica max consentita all'avviamento Max kinematic viscosity suggested at the start-up		VG= 750 cSt			
Indice di viscosità consigliato Viscosity index suggested		VI > 100			
		Temperatura di esercizio Working temperature			
		-15°C ÷ 100°C			
Grado di filtrazione Oil filtering		> 200 bar: 10 µm < 200 bar: 25 µm			
Pres. di aspirazione Inlet pressure		0,85 ÷ 2 bar assoluti/absolut			
Senso di rotazione Pump rotation		Bidirezionale Bidirectional			
Verificare che la pompa sia posizionata almeno 100 mm sotto il livello minimo del serbatoio olio. Prima di avviare la pompa effettuare spurgo aria. Verify that pump is, at least, 100 mm under the minimum level of the tank. Before starting the pump bleed the air.					

15/03/2021

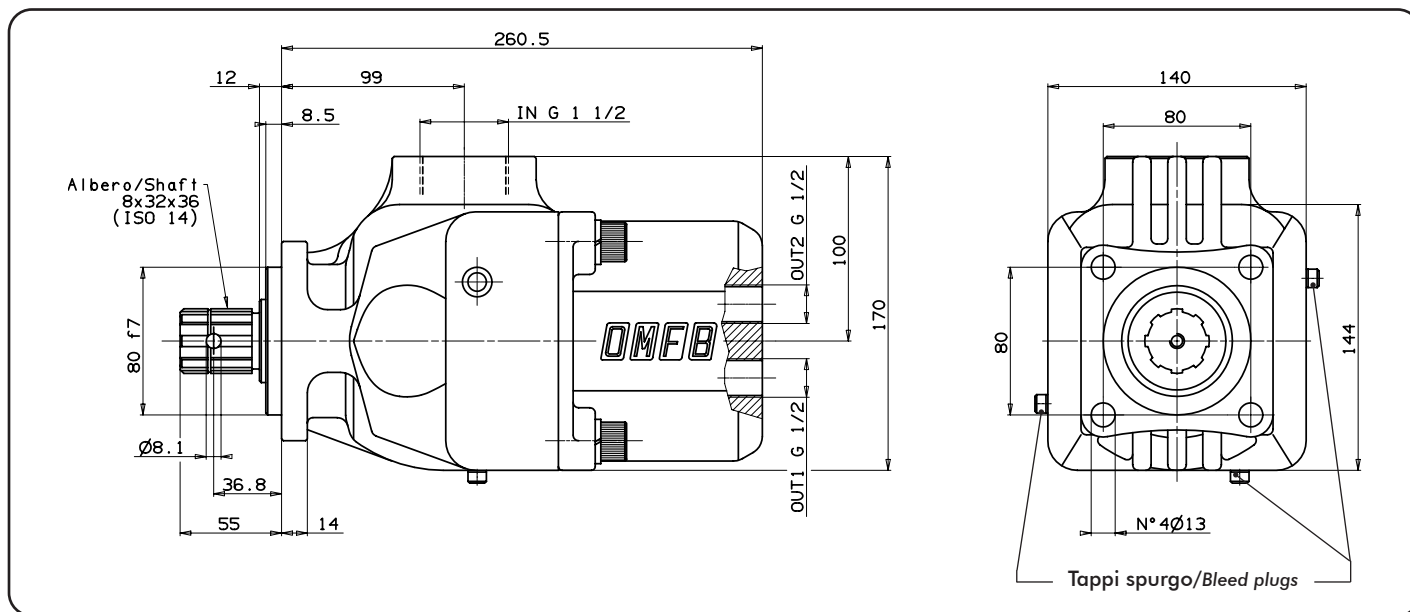

99710800810 Rev. AG

Tipo pompa Pump type	Codice Code	Cilindrata Displacement	OUT 1	OUT 2	Pressione Pressure		Velocità max Max speed	Peso Weight
					Massima Max	Picco Peak		
		cm ³ /rev	cm ³ /rev	cm ³ /rev	bar	bar	rpm	kg
2PAK-35+35	10800835351	35+35	35	35	300	350	1500	21,5
2PAK-50+30	10800850307	50+30	30	50				21,3
2PAK-50+50	10800850503	50+50	50	50				21,2

pag.21



O.M.F.B. S.p.A. Hydraulic Components
We reserve the right to make any changes without notice.
Edition 2016.06 No reproduction, however partial, is permitted.
Via Cave, 7/9 25050 Provaglio d'Iseo (Brescia) Italy Tel.: +39.030.9830611
Fax: +39.030.9839207-208 Internet:www.omfb.it e-mail:contatti@omfb.it

COMPANY WITH
QUALITY SYSTEM
CERTIFIED BY DNV GL
= IATF 16949 =

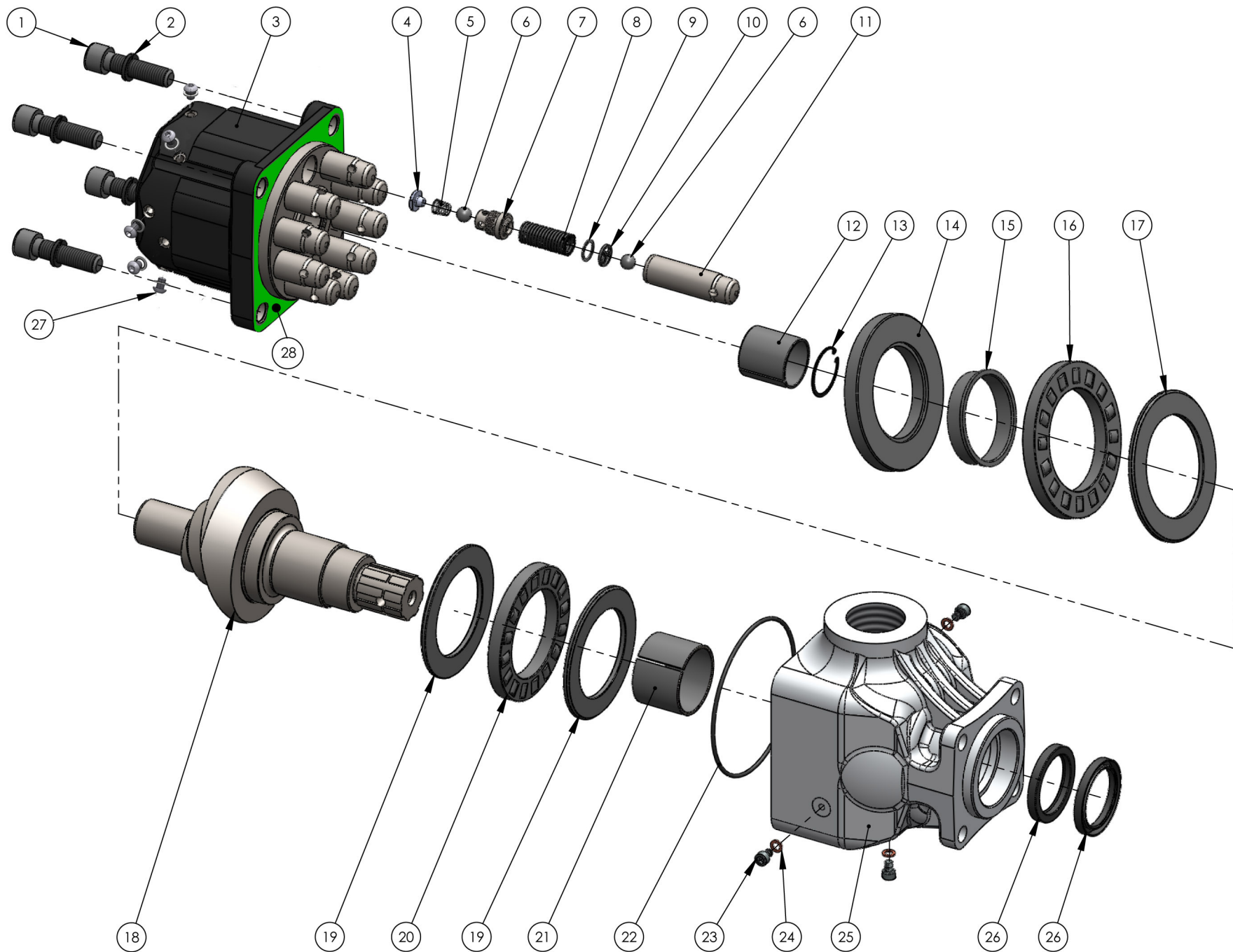

COMPANY WITH
QUALITY SYSTEM
CERTIFIED BY DNV GL
= IATF 16949 =

pag. 22

O.M.F.B. S.p.A. Hydraulic Components
We reserve the right to make any changes without notice.
Edition 2016.06 No reproduction, however partial, is permitted.
Via Cava, 7/9 25050 Provedolo d'Isco (Brescia) Italy Tel.: +39 030.9830611
Fax: +39 030.9839207-208 Internet: www.omfb.it e-mail: contact@omfb.it





O.M.F.B. S.p.A. Hydraulic Components
 We reserve the right to make any changes without notice.
 Edition 2016.06 No reproduction, however partial, is permitted.
 Via Cove, 719 25050 Povoaglio d'Isèo (Brescia) Italy. Tel.: +39 030 9830611
 Fax: +39 030 9839207 208 Internet: www.omfeb.it e-mail: conthi@omfeb.it

pag. 23

COMPANY WITH
 QUALITY SYSTEM
 CERTIFIED BY DNV GL
 = IATF 16949 =

N°	35+35	50+30	50+50	Codice P. Number	Descrizione / Description		Q.
1	•	•	•	50200600581	Vite TCE M14x55	Socket head capscrew	4
2	•	•	•	50100800072	Rondella elastica	Washer	4
3	•			51700235350	Corpo posteriore	Rear body	1
		•		51700250306			
			•	51700250502			
4	• x8	• x9	• x10	54200100135	Corpo guida molla	Spring guide body	
5	• x8	• x9	• x10	51200400153	Molla conica	Tapered spring	
6	• x16	• x18	• x20	51000900116	Sfera grano 7/16"	Ball 7/16"	
7	• x8	• x9	• x10	54000000149	Tappo valvola mandata	Plug delivery valve	
8	• x8	• x9	• x10	51200501946	Molla ritorno pistone	Back piston spring	
9	• x8	• x9	• x10	53000000159	Distanziale	Spacer	
10	• x8	• x9	• x10	55000100209	Part. arresto sfera pompanti	Spacer sprine guide	
11	• x8	• x9		53200400044	Pistone pompante ø21	Pump piston ø21	
			• x10	53200400053	Pistone pompante ø22	Pump piston ø22	
12	•	•	•	53300400140	Boccola 35x39x40	Bushing 35x39x40	1
13	•	•	•	50100000196	Anello elastico	Circlip	1
14	•	•	•	51000600404	Ralla 70x119x12.5	Bearing 70x119x12.5	1
15	•	•	•	53300400257	Boccola 65x70x15	Bushing 65x70x15	1
16	•	•	•	51000680122	Gabbia assiale rulli 78x119x11	Axial roller cage 78x119x11	1
17	•	•	•	51000600397	Ralla 78x115x4.5	Bearing 78x115x4.5	1
18	•	•	•	52200500133	Albero	Shaft	1
19	•	•	•	51000600440	Ralla 70x104x4.5	Bearing 70x104x4.5	2
20	•	•	•	51000670106	Gabbia assiale rulli 70x106x11	Axial roller cage 70x106x11	1
21	•	•	•	53300400177	Boccola 50x55x40	Bushing 50x55x40	1
22	•	•	•	50600200676	Guarnizione OR	O-Ring	1
23	•	•	•	50200200405	Vite TCE M 6x10	Socket head capscrew	3
24	•	•	•	11600901022	Rondella in rame	Washer	3
25	•	•	•	51700200299	Corpo anteriore	Front housing	1
26	•	•	•	50600700706	Paraolio	Oil seal	2
27	• x8	• x9	• x10	50210600106	Vite TBCE M6x 8 ISO 7380	Screw TBCE M6x8 ISO 7380	
				11600910067	Rondella acciaio/gomma x M6	Steel/rubber washer x M6	
28	•	•	•	50700000452	Guarnizione	Gasket	1

PORTATA
FLOW

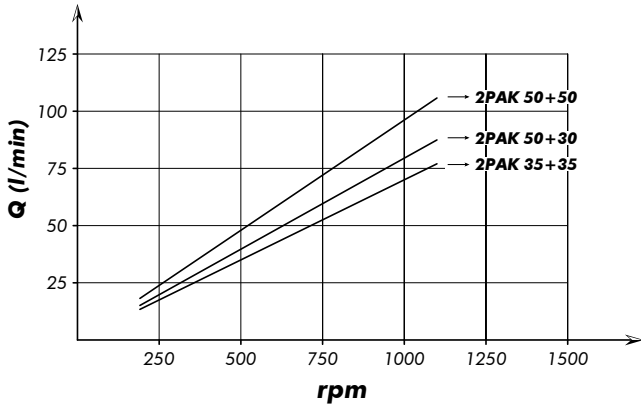

COPPIA ASSORBITA
DRIVE TORQUE

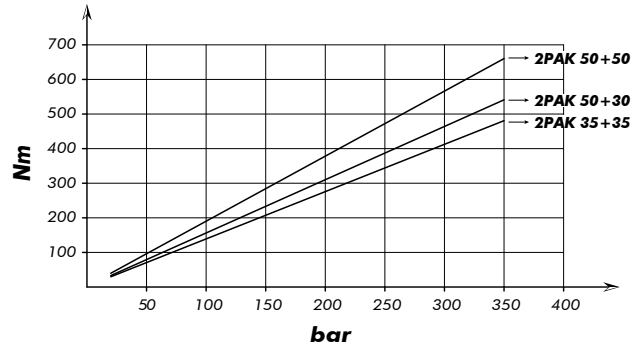

POTENZA ASSORBITA
POWER INPUT

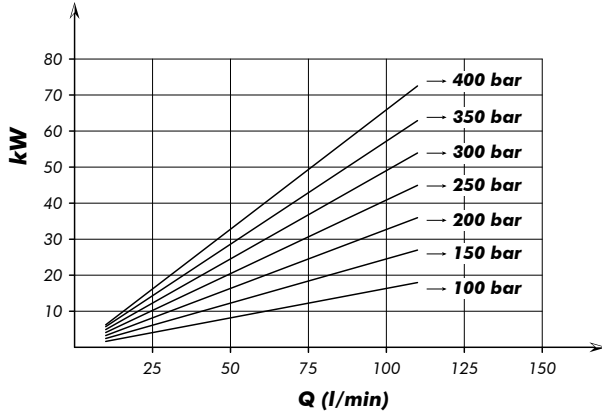

MOMENTO PESO / MASS MOMENT

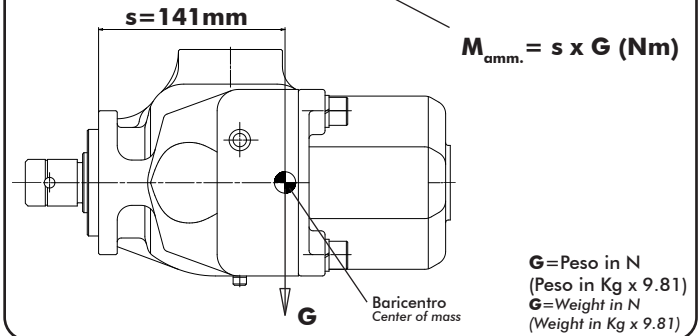

La quota "s" può essere considerata unica per tutte le cilindrata.
"s" dimension can be considered valid for all pump displacement.

Kit guarnizioni
Seal Kit

10890300036

99740060010

15/03/2021

99710800810 Rev: AG

GAMMA POMPE A PISTONI

CODICE FAMIGLIA

60x

"HDS" "MDS"
"HDT"

CODIFICA VERSIONI

99740060010

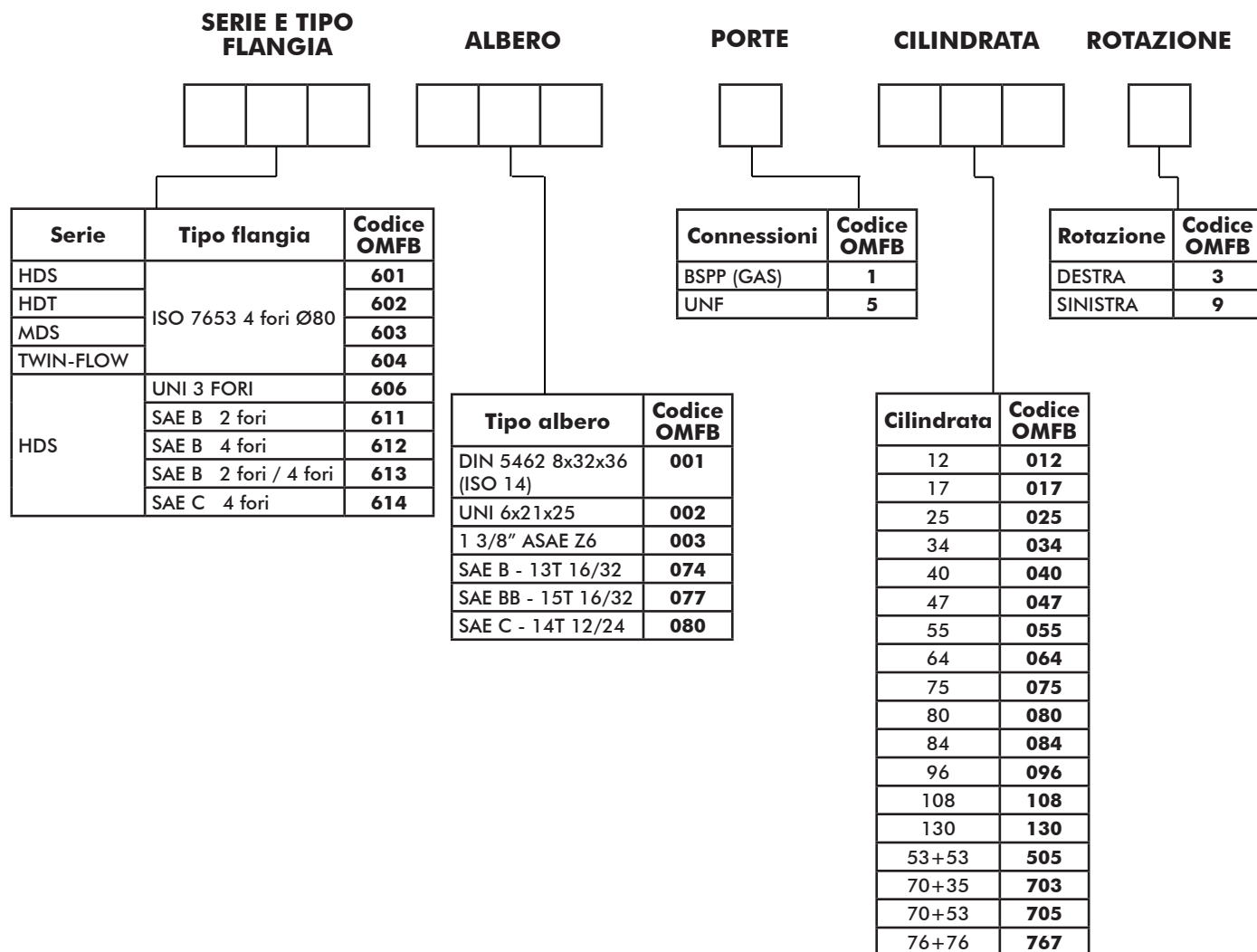

PISTON PUMPS RANGE

"HDS" "MDS"
"HDT"

VERSIONS CODING

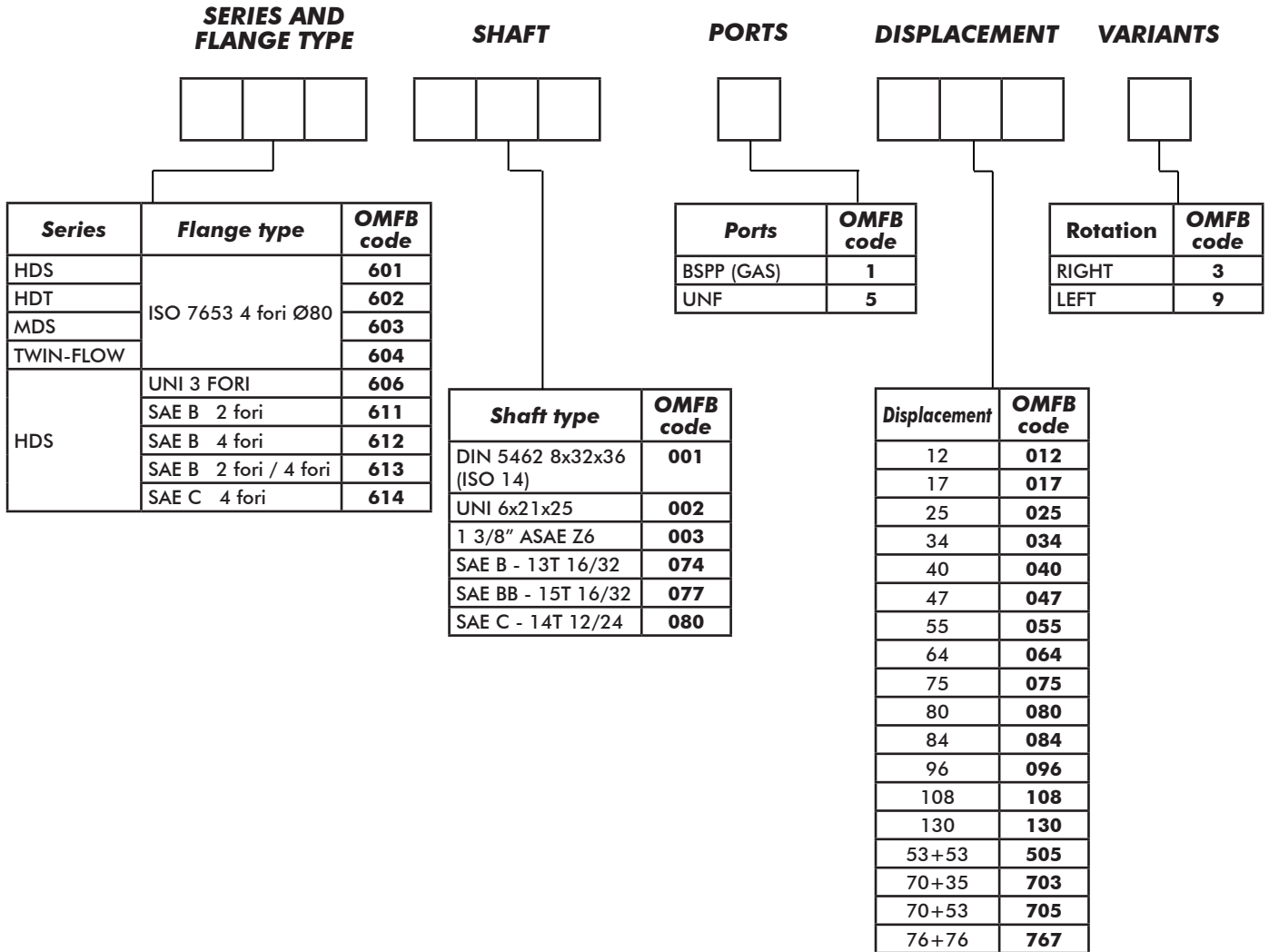

99740060010

POMPE A PISTONI AD ASSE INCLINATO BENT AXIS PISTON PUMPS

CODICE FAMIGLIA
FAMILY CODE

601001

"HDS"

Flangia/Flange
Albero/Shaft
Cilin./Displ.

ISO
ISO14 8x32x36
12-17-25-34



99740060010

Fluido idraulico Fluid	Minerale o sintetico compatibile con guarnizioni: Mineral or synthetic compatible with the following seals: FKM, FPM, HNBR				
Viscosità cinematica consigliata Kinematic viscosity suggested	T media ambiente (°C) Average ambient temp. (°C)	< -40	-40 ÷ 10	10 ÷ 35	> 35
	VG (cSt = mm ² /s)	16	22	32	46
Viscosità cinematica ottimale di esercizio Optimale kinematic viscosity		VG = 10 cSt ÷ 100 cSt			
Viscosità cinematica max consentita all'avviamento Max kinematic viscosity suggested at the start-up		VG = 750 cSt			
Indice di viscosità consigliato Viscosity index suggested	VI > 100	Temperatura di esercizio Working temperature -40°C ÷ 140°C			
Grado di filtrazione Oil filtering		> 200 bar: 10 µm < 200 bar: 25 µm			
Pres. di aspirazione Inlet pressure		0,85 ÷ 2 bar assoluti/absolut			
Senso di rotazione Pump rotation		Unidirezionale (Dx o Sx) Unidirectional (Right or Left)			
Verificare che la pompa sia posizionata almeno 100 mm sotto il livello minimo del serbatoio olio. Prima di avviare la pompa effettuare spurgo aria. Verify that pump is, at least, 100 mm under the minimum level of the tank. Before starting the pump bleed the air.					

Dimensions in mm

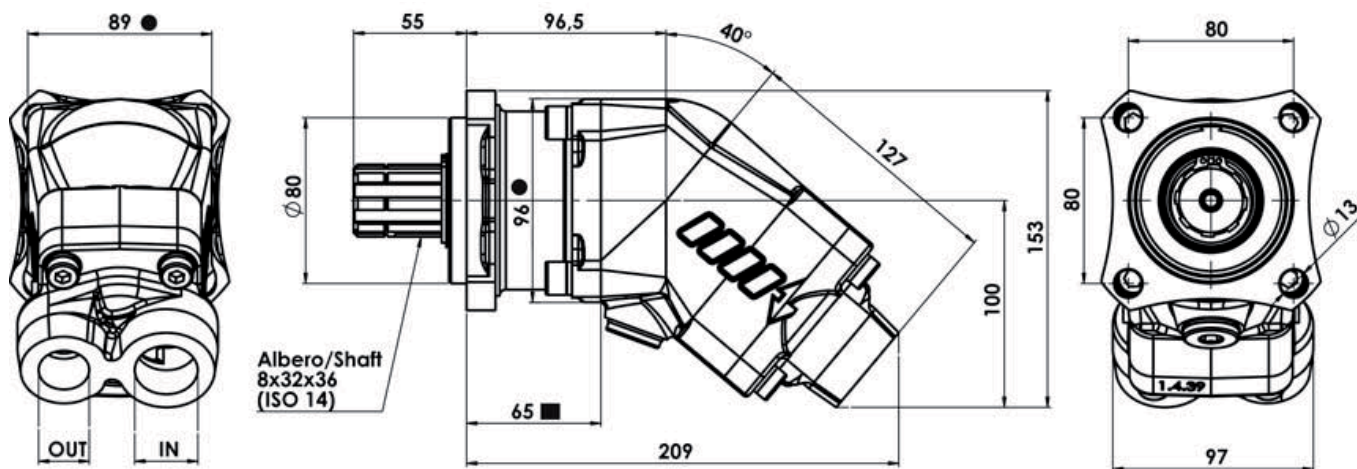

● Larghezza minima corpo a quota indicata
Minimum bodywidth at indicated measurement

30/03/2016

99760101510 Rev. //

Tipo pompa Pump type	Rotazione Rotation		IN	OUT	IN	OUT
	Destra Right	Sinistra Left				
HDS-12	60100110123	60100110129	ISO 228 G 1	ISO 228 G 3/4	SAE	SAE
HDS-17	60100110173	60100110179	G 1	G 3/4		
HDS-25	60100110253	60100110259	G 1	G 3/4		
HDS-34	60100110343	60100110349	G 1	G 3/4		

pag.27

O.M.F.B. S.p.A. Hydraulic Components

We reserve the right to make any changes without notice.

Edition 2016.06 No reproduction, however partial, is permitted.

Via Cave, 7/9 25050 Provaglio d'Iseo (Brescia) Italy Tel.: +39.030.9830611
Fax: +39.030.9839207-208 Internet:www.omfb.it e-mail:contatti@omfb.it

COMPANY WITH
QUALITY SYSTEM
CERTIFIED BY DNV GL
= IATF 16949 =



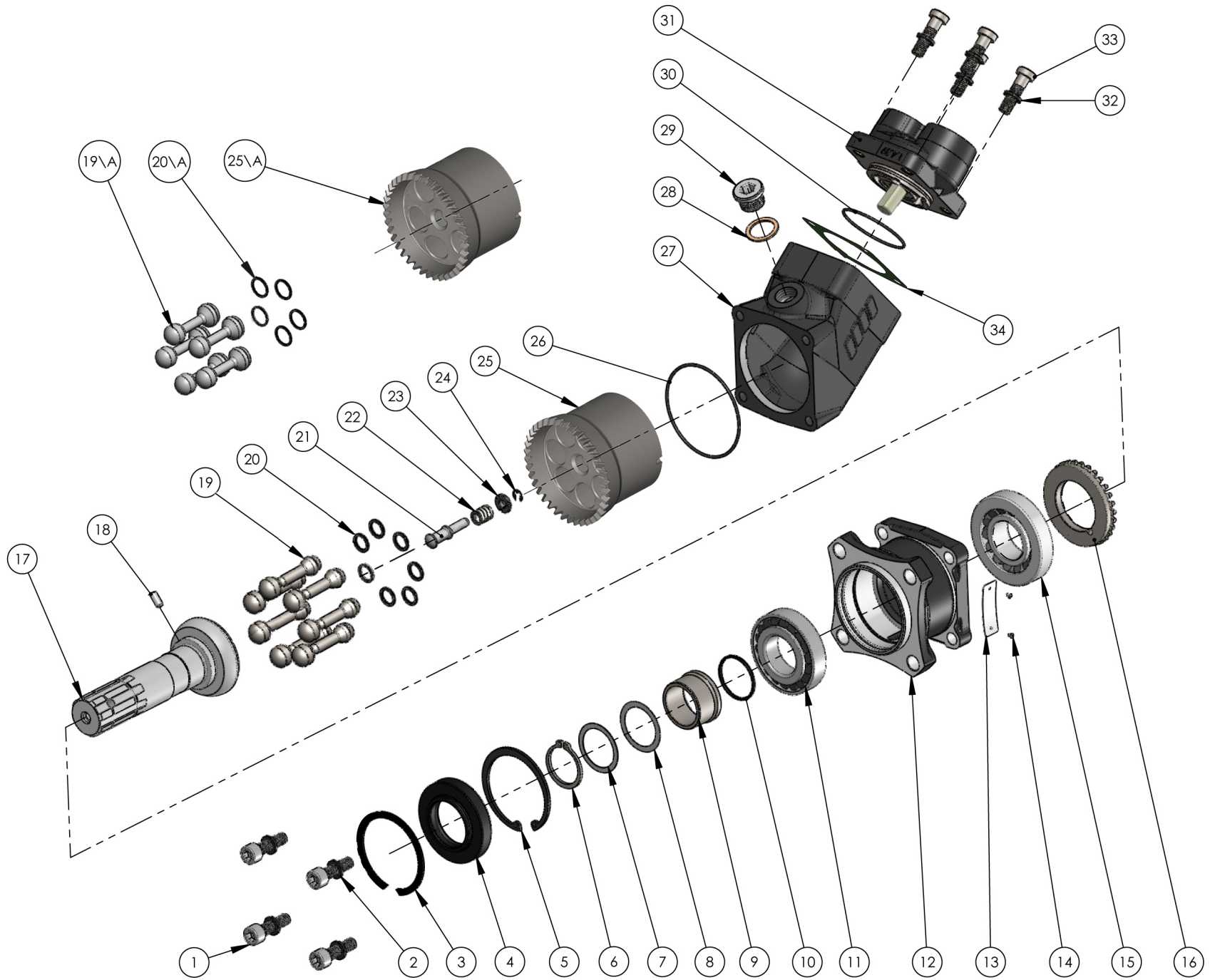



O.M.F.B. S.p.A. Hydraulic Components
 We reserve the right to make any changes without notice.
 Edition 2016.06 No reproduction, however partial, is permitted.
 Via Cove, 719 25050 Povoaglio d'Isèo (Brescia) Italy Tel.: +39 030 9830611
 Fax: +39 030 9839207 208 Internet: www.omfb.it e-mail: comfthi@omfb.it

pag. 29

COMPANY WITH
 QUALITY SYSTEM
 CERTIFIED BY DNV GL
 = IATF-16949 =

N° N°	HDS 12 GAS	HDS 17 GAS	HDS 25 GAS	HDS 34 GAS	Codice P. Number	Descrizione Description	Q.tà Q.ty	
1	50200400565	Vite TCE M 10x35	Socket head capscrew	4
2	50100800054	Rosetta elastica	Washer	4
3	50100002729	Anello elastico	Circlip	1
4	50600024272	Paraolio	Oil seal	1
5	50100100677	Anello elastico	Circlip	1
6	50100001355	Anello seeger rinforzato	Retaining ring	1
7	52900701127	Rondella	Spacers	2
8	52900700226	Rondella	Spacers	2
9	51100200200	Bussola	Bushing	1
10	50600013137	Guarnizione OR	O-ring	1
11	51000200211	Cuscinetto a rulli conici	Tapered roller bearing	1
12	51700201154	Corpo anteriore	Front housing	1
13	513	Targhetta completa	Plate	1
14	51300000011	Chiodino fiss. targhetta	Plate nail	2
15	51000200373	Cuscinetto a rulli conici	Tapered roller bearing	1
16	52501100264	Corona dentata	Crown	1
17	52200500357	Albero	Shaft	1
18	52200500268	Albero	Shaft	1
19	50100306142	Spina UNI 6364	Pin UNI 6364	1
19A	53200500061	Pistone sferico	Piston	7
20	53200500052	Pistone sferico	Piston	5
20A	53200500061	Pistone sferico	Piston	5
21	53200500052	Pistone sferico	Piston	5
22	50102300064	Fasce elastiche	Spring rings	21
23	50102300073	Fasce elastiche	Spring rings	15
24	50102300064	Fasce elastiche	Spring rings	15
25	50102300073	Fasce elastiche	Spring rings	15
26	54200100313	Perno sferico con guida albero	Shaft guide pin	1
27	54200100162	Perno sferico con guida albero	Shaft guide pin	1
28	51200501651	Molla di carico corpo cilindri	Spring	1
29	51200500812	Molla di carico corpo cilindri	Spring	1
30	54200100322	Anello guida molla	Spring guide ring	1
31	54200100171	Anello guida molla	Spring guide ring	1
32	50101500046	Anello seeger	Retaining ring	1
33	50101500028	Anello seeger	Retaining ring	1
34	50002916034	Gruppo corpo cilindri sede pistoni	Piston barrel assembly	1
35	50002916025	Gruppo corpo cilindri sede pistoni	Piston barrel assembly	1
36	50002916017	Gruppo corpo cilindri sede pistoni	Piston barrel assembly	1
37	50002916012	Gruppo corpo cilindri sede pistoni	Piston barrel assembly	1
38	50600018020	Guarnizione OR	O-ring	1
39	51700200717	Corpo intermedio	Int. housing	1
40	11600910129	Rondella rame	Copper washer	1
41	11500600135	Tappo cieco	Blank plug	1
42	50600012224	Guarnizione OR	O-ring	1
43	50002980340	Gruppo corpo posteriore	Rear cover assembly	1
44	50002980251	Gruppo corpo posteriore	Rear cover assembly	1
45	50002980171	Gruppo corpo posteriore	Rear cover assembly	1
46	50002980126	Gruppo corpo posteriore	Rear cover assembly	1
47	50102000101	Rosetta elastica	Washer	4
48	50200400556	Vite TCE M10x30	Socket head capscrew	4
49	A	A	A	A	50700000256	Guarnizione piatta	Gasket	1
50	A	A	A	A	50700000523	Guarnizione piatta	Gasket	1

A = alternative

CARATTERISTICHE TECNICHE DI FUNZIONAMENTO / TECHNICAL FEATURES

Tipo pompa Pump type	Cilindrata Displacement cm ³ /rev	Pressione Pressure		Velocità / Speed			Velocità min. Min. speed rpm	Peso Weight kg
		P1 bar	P3 bar	V0 rpm	V1 rpm	V2 rpm		
HDS-12	12.62	350	400	3000	2300	3000	300	8,8
HDS-17	16.98							8,6
HDS-25	25.12							8,8
HDS-34	33.80							8,6

P1=Pressione massima continua Max. continuous pressure (100%)
P3=Pressione massima di punta Max. peak pressure (6 sec.max)

V0=Massima continua vuoto Max. continuous speed without load
V1=Massima continua Max. continuous speed
V2=Massima intermittente Max. intermittent speed

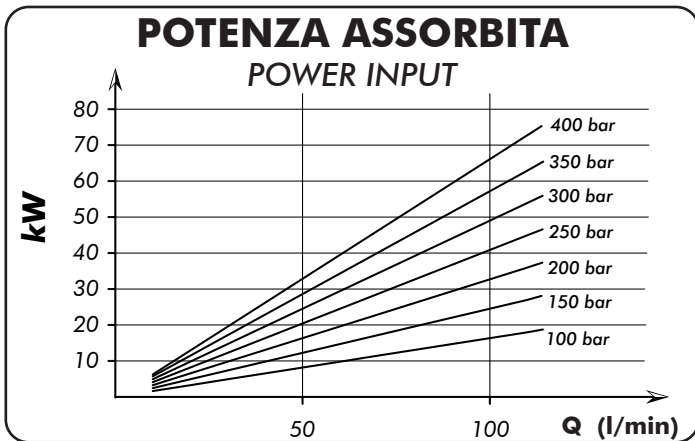
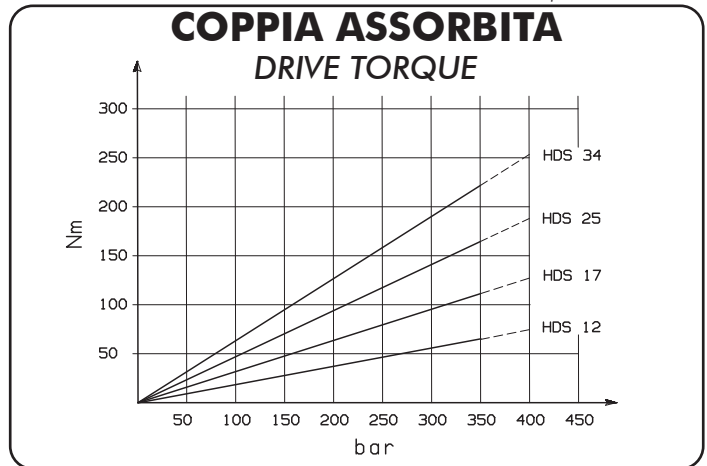
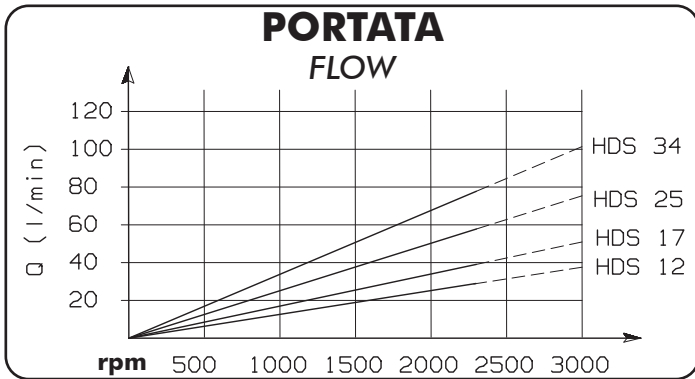

SCELTA DEL TUBO DI ASPIRAZIONE HOW TO CHOOSE THE SUCTION PIPE SIZE

Q Portata Flow l/min	Ø interno min. tubo Min pipe diam. mm inch		Velocità flusso Flow speed (m/s)
20	25	1"	0,68
30	32	1" 1/4	0,62
40	32		0,83
50	38	1" 1/2	0,74
60	38		0,88
70	40	1" 9/16	0,93
80	45	1" 3/4	0,84
90	45		0,94
100	50	2"	0,85
110	50		0,93
120	60	2" 3/8	0,71
130	60		0,77
140	60		0,83
150	60		0,88
160	63	2" 1/2	0,86
170	63		0,91
180	63		0,96

Per garantire corrette condizioni di aspirazione la velocità del flusso non deve superare 1 m/sec.
To ensure the proper suction pipe size the flow speed should not exceed 1mt/sec.

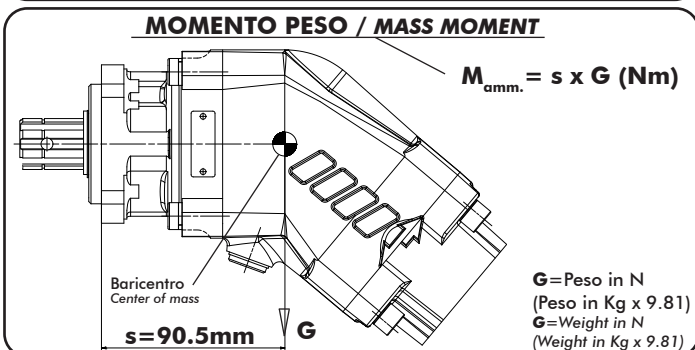
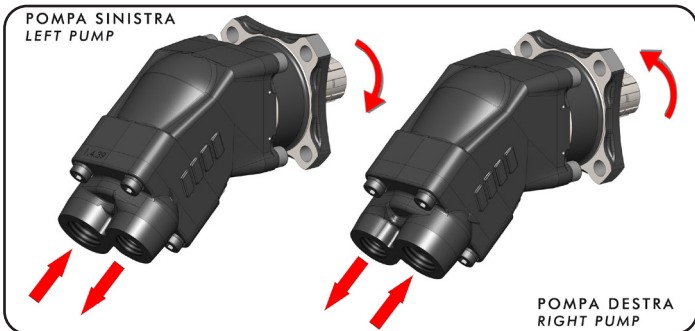

Kit guarnizioni / Seal Kit
10890325340

POMPE A PISTONI AD ASSE INCLINATO BENT AXIS PISTON PUMPS

CODICE FAMIGLIA
FAMILY CODE

601001
603001

"HDS"
"MDS"

Flangia/Flange
Albero/Shaft
Cilin./Displ.

ISO
ISO14 8x32x36
40-47-55-64-80

99740060010



Fluido idraulico Fluid	Minerale o sintetico compatibile con guarnizioni: Mineral or synthetic compatible with the following seals: FKM, FPM, HNBR				
Viscosità cinematica consigliata Kinematic viscosity suggested	T media ambiente (°C) Average ambient temp. (°C)	< -40	-40 ÷ 10	10 ÷ 35	> 35
	VG (cSt = mm ² /s)	16	22	32	46
Viscosità cinematica ottimale di esercizio Optimale kinematic viscosity			VG = 10 cSt ÷ 100 cSt		
Viscosità cinematica max consentita all'avviamento Max kinematic viscosity suggested at the start-up			VG = 750 cSt		
Indice di viscosità consigliato Viscosity index suggested	VI > 100	Temperatura di esercizio Working temperature -40°C ÷ 140°C			
Grado di filtrazione Oil filtering		> 200 bar: 10 µm < 200 bar: 25 µm			
Pres. di aspirazione Inlet pressure		0,85 ÷ 2 bar assoluti/absolut			
Senso di rotazione Pump rotation		Unidirezionale (Dx o Sx) Unidirectional (Right or Left)			
Verificare che la pompa sia posizionata almeno 100 mm sotto il livello minimo del serbatoio olio. Prima di avviare la pompa effettuare spurgo aria. Verify that pump is, at least, 100 mm under the minimum level of the tank. Before starting the pump bleed the air.					

Dimensions in mm

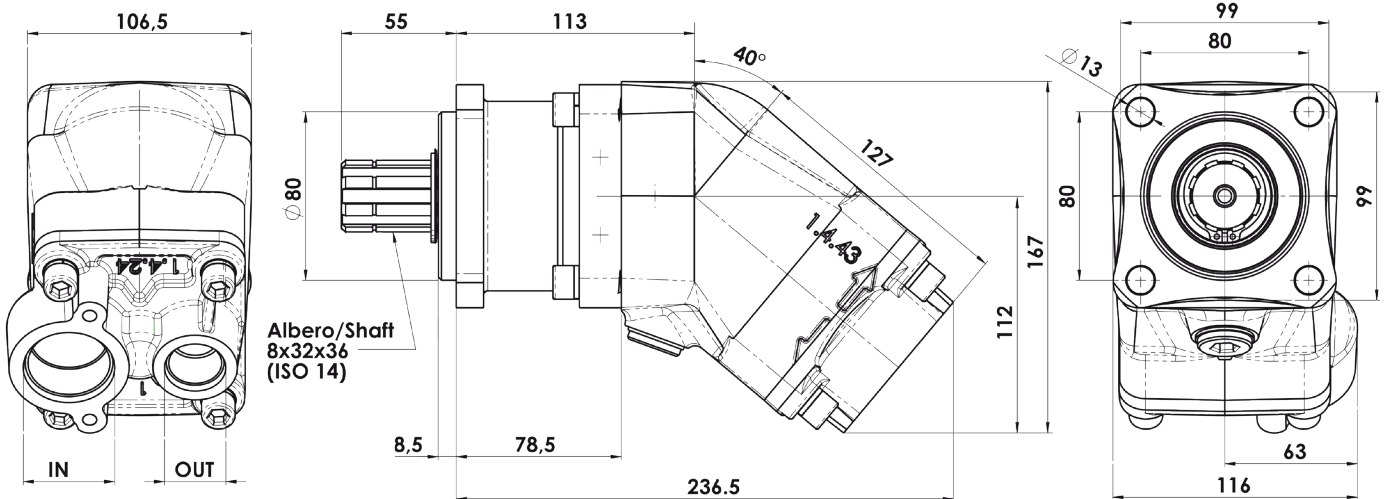

Albero/Shaft
8x32x36
(ISO 14)

07/03/2017

99760101515 Rev. AA

Tipo pompa Pump type	Rotazione Rotation		IN	OUT
	Destra Right	Sinistra Left		
HDS-40	60100110403	60100110409	ISO 228	ISO 228
HDS-47	60100110473	60100110479		
HDS-55	60100110553	60100110559		
HDS-64	60100110643	60100110649		
MDS-80	60300110803	60300110809		
			G 1 1/4"	G 3/4"
HDS-40	60100150403	60100150409		
HDS-47	60100150473	60100150479		
HDS-55	60100150553	60100150559		
HDS-64	60100150643	60100150649		
MDS-80	60300150803	60300150809	ISO 725	ISO 725
HDS-40	60100150403	60100150409		
HDS-47	60100150473	60100150479		
HDS-55	60100150553	60100150559		
HDS-64	60100150643	60100150649		
MDS-80	60300150803	60300150809	1 5/8-12 UN-2B SAE 20	1 1/16-12 UN-2B SAE 12
HDS-40	60100150403	60100150409		
HDS-47	60100150473	60100150479		
HDS-55	60100150553	60100150559		
HDS-64	60100150643	60100150649		
MDS-80	60300150803	60300150809		

pag.31

O.M.F.B. S.p.A. Hydraulic Components

We reserve the right to make any changes without notice.

Edition 2016.06 No reproduction, however partial, is permitted.

Via Cave, 7/9 25050 Provaglio d'Iseo (Brescia) Italy Tel.: +39.030.9830611
Fax: +39.030.9839207-208 Internet:www.omfb.it e-mail:contatti@omfb.it

**COMPANY WITH
QUALITY SYSTEM
CERTIFIED BY DNV GL
= IATF 16949 =**



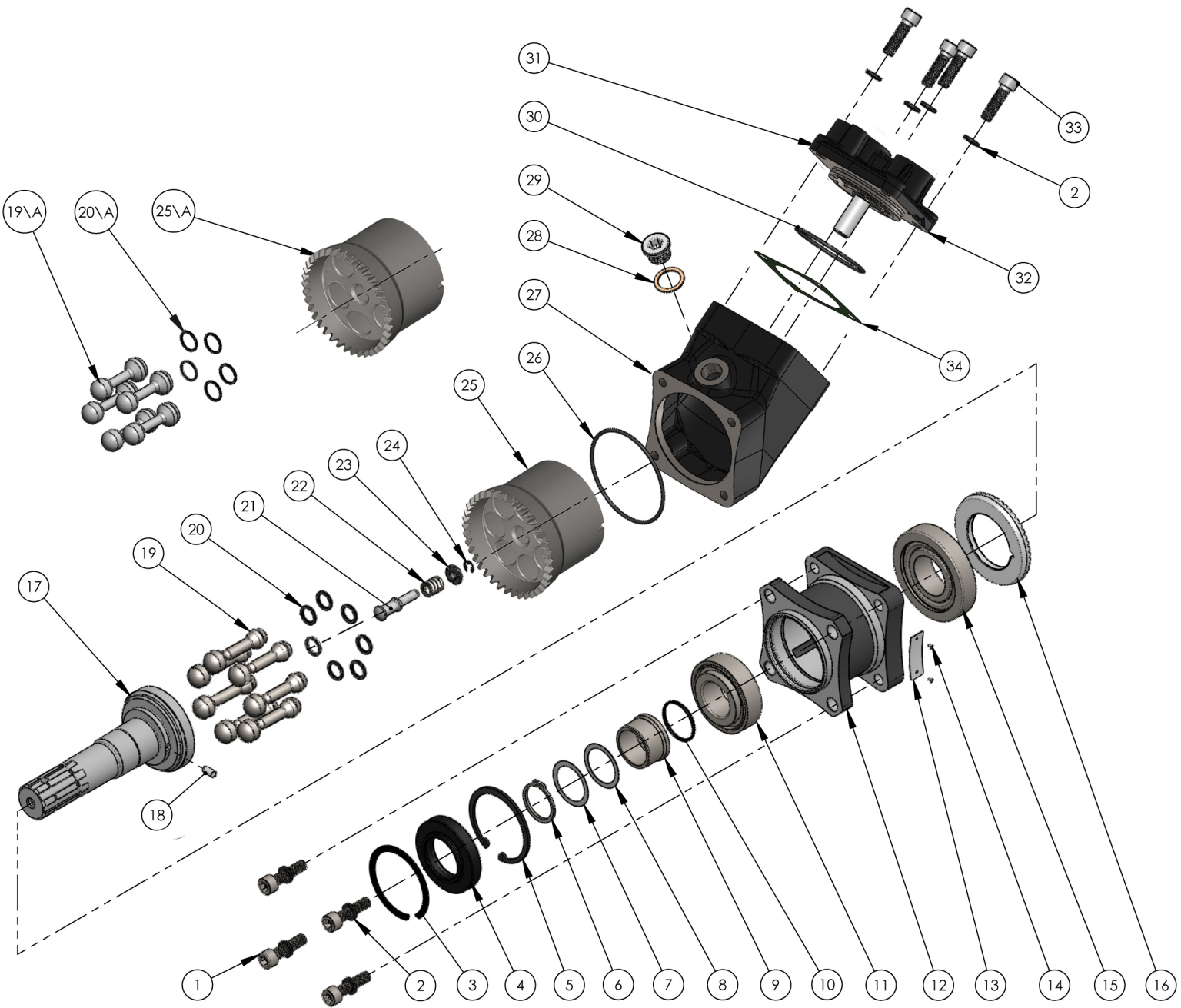



N°	HDS 40		HDS 47		HDS 55		HDS 64		MDS 80		Codice P. Number	Descrizione Description	Q.tà Q.ty	
	GAS	SAE	GAS	SAE	GAS	SAE	GAS	SAE	GAS	SAE				
1	50200400574	Vite TCE M 10x40 UNI 5931	Socket head capscrew M 10x40 UNI 5931	4
2	50100800054	Rosetta elastica x M10 DIN 7980	Washer x M10 DIN 7980	4
3	50100002729	Anello elastico E-SB 72x2	Circlip E-SB 72x2	1
4	50600024272	Paraolio HNBR	Oil seal HNBR	1
5	50100100677	Anello elastico Ø72 I	Circlip Ø72 I	1
6	50100001355	Anello seeger rinforzato AS UNI 7436	Retaining ring AS UNI 7436	1
7	52900701127	Rondella 44x35x0.2	Washer 44x35x0.2	1
8	52900700226	Rondella 44x35x0.1	Washer 44x35x0.1	1
9	51100200200	Bussola	Bushing	1
10	50600013137	Guarnizione OR 3137 HNBR	O-ring 3137 HNBR	1
11	51000200220	Cuscinetto a rulli conici	Tapered roller bearing	1
12	51700201163	Corpo anteriore	Front housing	1
13	513	Targhetta completa	Plate	1
14	51300000011	Chiodino fissaggio targhetta	Plate nail	2
15	51000200275	Cuscinetto a rulli conici	Tapered roller bearing	1
16	52501100255	Corona dentata	Crown	1
17	52200500231	Albero	Shaft	1
18	52200500204	Spina UNI 6364-A Ø6x14	Pin UNI 6364-A Ø6x14	1
19	50100306142	Pistone sferico	Piston	7
											53200500285			
											53200500025			
											53200500114			
											53200500016			
19a	53200500043			5
20	50102300064	Fasce elastiche	Spring rings	21
											50102300046			
											50102300126			
20a	50102300019			15
											50102300082			
21	54200100162	Perno sferico con guida albero	Shaft guide pin	1
22	51200500812	Molla di carico corpo cilindri	Spring	1
23	54200100171	Anello guida molla	Spring guide ring	1
24	50101500028	Anello seeger RS 6 DIN 6799	Retaining ring RS 6 DIN 6799	1
25	50002916040	Gruppo corpo cilindri sede pistoni	Piston barrel assembly	1
											50002916047			
											50002916055			
											50002916064			
25a	50002916080			
26	50600013350	Guarnizione OR 3350 HNBR	O-Ring 3350 HNBR	1
27	51700201421	Corpo intermedio	Intern. housing	1
28	11600910129	Rondella acciaio/gomma 1/2"	Washer 1/2"	1
29	11500600135	Tappo cieco 1/2" DIN 908	Blank plug 1/2" DIN 908	1
30	50600013275	Guarnizione OR 3275 HNBR	O-ring OR 3275 HNBR	1
31	50002990400	Gruppo corpo posteriore	Rear cover assembly	1
											50002990419			
											50002990473			
											50002990482			
											50002990553			
											50002990562			
											50002990642			
											50002990651			
											50002990802			
											50002990811			
32	50100800054	Rosetta elastica x M10 DIN 7980	Washer x M10 DIN 7980	4
33	50200400565	Vite TCE M10x35 UNI 5931	Socket head capscrew M10x35 UNI 5931	4
34	A	A	A	A	A	A	A	A	A	A	50700000229	Guarnizione piatta	Gasket	1
	A	A	A	A	A	A	A	A	A	A	50700000532			

A = alternative

CARATTERISTICHE TECNICHE DI FUNZIONAMENTO / TECHNICAL FEATURES

Tipo pompa Pump type	Cilindrata Displacement cm ³ /rev	Pressione Pressure		Velocità / Speed			Velocità min. Min. speed rpm	Peso Weight kg
		P1 bar	P3 bar	V0 rpm	V1 rpm	V2 rpm		
HDS-40	41.25	350	400	2700	1900	2500	300	12,3
HDS-47	47.13							
HDS-55	56.70							
HDS-64	63.56							
MDS-80	77.25	250	300	2300	1800	2100		12

P1=Pressione max.continua Max. continuous pressure (100%)
P3=Pressione max. di punta Max. peak pressure (6 sec.max)

V0=Max. continua vuoto Max. continuous speed without load
V1=Max. continua Max. continuous speed
V2=Max. intermittente Max. intermittent speed

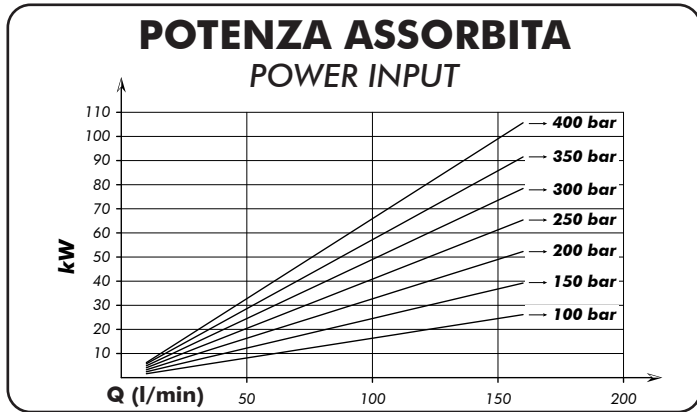
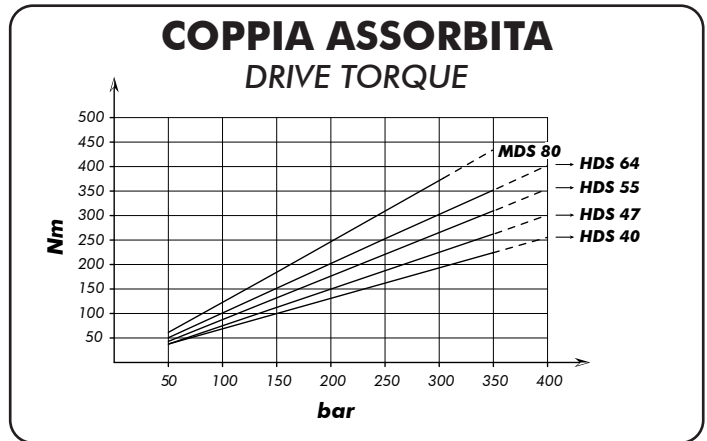
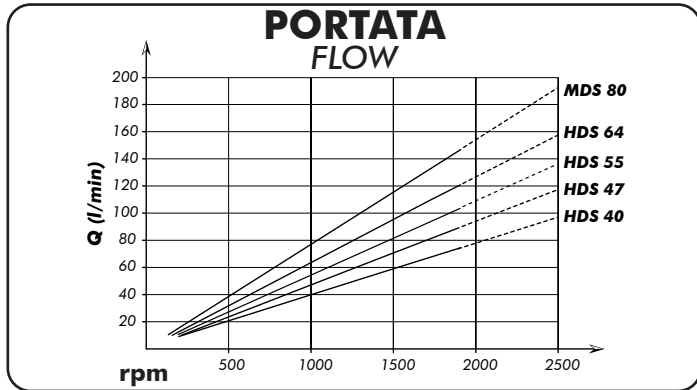

SCELTA DEL TUBO DI ASPIRAZIONE HOW TO CHOOSE THE SUCTION PIPE SIZE

Q Portata Flow l/min	Ø interno min. tubo Min pipe diam. mm inch		Velocità flusso Flow speed (m/s)
20	25	1"	0,68
30	32	1" 1/4	0,62
40	32	1" 1/4	0,83
50	38	1" 1/2	0,74
60	38	1" 1/2	0,88
70	40	1" 9/16	0,93
80	45	1" 3/4	0,84
90	45	1" 3/4	0,94
100	50	2"	0,85
110	50	2"	0,93
120	60	2"	0,71
130	60	2" 3/8	0,77
140	60	2" 3/8	0,83
150	60	2" 3/8	0,88
160	63	2" 1/2	0,86
170	63	2" 1/2	0,91
180	63	2" 1/2	0,96

Per garantire corrette condizioni di aspirazione la velocità del flusso non deve superare 1 m/sec.
To ensure the proper suction pipe size the flow speed should not exceed 1mt/sec.

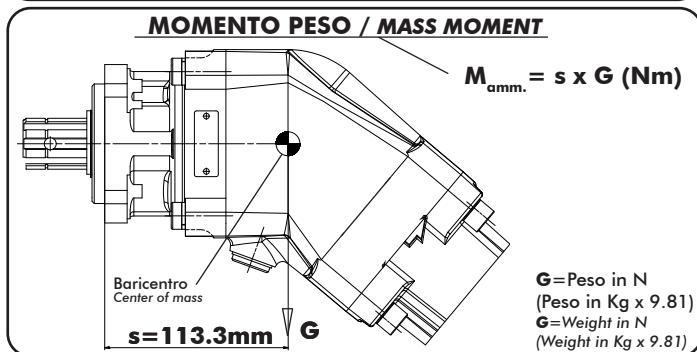
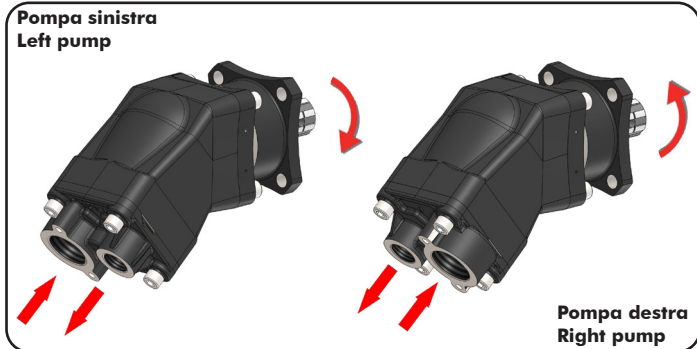

POMPE A PISTONI AD ASSE INCLINATO BENT AXIS PISTON PUMPS

CODICE FAMIGLIA
FAMILY CODE

601001
603001

"HDS"
"MDS"

Flangia/Flange
Albero/Shaft
Cilin./Displ.

ISO
ISO14 8x32x36
84-108-120-130



99740060010

Fluido idraulico Fluid	Minerale o sintetico compatibile con guarnizioni: Mineral or synthetic compatible with the following seals: FKM, FPM, HNBR				
Viscosità cinematica consigliata Kinematic viscosity suggested	T media ambiente (°C) Average ambient temp. (°C)	< -40	-40÷10	10÷35	> 35
	VG (cSt = mm ² /s)	16	22	32	46
Viscosità cinematica ottimale di esercizio Optimale kinematic viscosity		VG = 10 cSt ÷ 100 cSt			
Viscosità cinematica max consentita all'avviamento Max kinematic viscosity suggested at the start-up		VG = 750 cSt			
Indice di viscosità consigliato Viscosity index suggested	VI > 100	Temperatura di esercizio Working temperature			
		-40°C ÷ 140°C			
Grado di filtrazione Oil filtering		> 200 bar: 10 µm < 200 bar: 25 µm			
Pres. di aspirazione Inlet pressure		0,85 ÷ 2 bar assoluti/absolut			
Senso di rotazione Pump rotation		Unidirezionale (Dx o Sx) Unidirectional (Right or Left)			
Verificare che la pompa sia posizionata almeno 100 mm sotto il livello minimo del serbatoio olio. Prima di avviare la pompa effettuare spurgo aria. Verify that pump is, at least, 100 mm under the minimum level of the tank. Before starting the pump bleed the air.					

Dimensions in mm

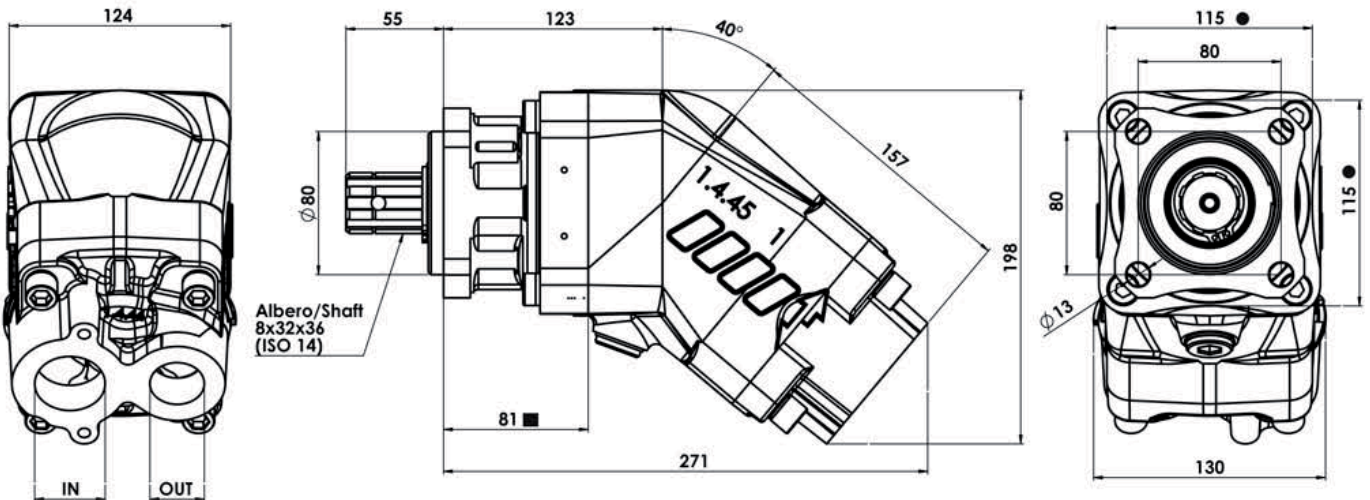

● Larghezza minima corpo a quota indicata ■
Minimum bodywidth at indicated measurement

Tipo pompa Pump type	Rotazione / Rotation		IN ISO 228 G 1 1/4"	OUT ISO 228 G 1"
	Destra / Right	Sinistra / Left		
HDS-84	60100110843	60100110849	G 1 1/2"	G 1"
HDS-108	60100111083	60100111089		
HDS-130	60100111303	60100111309		
MDS-120	60300111203	60300111209		
MDS-130	60300111303	60300111309		
			ISO 725	ISO 725
HDS-84	60100150843	60100150849	1 7/8-12 UN-2B SAE 24	1 5/16-12 UN-2B SAE 16
HDS-108	60100151083	60100151089		
HDS-130	60100151303	60100151309		
MDS-120	60300151203	60300151209		
MDS-130	60300151303	60300151309		

pag.35

O.M.F.B. S.p.A. Hydraulic Components

We reserve the right to make any changes without notice.

Edition 2016.06 No reproduction, however partial, is permitted.

Via Cave, 7/9 25050 Provaglio d'Iseo (Brescia) Italy Tel.: +39.030.9830611
Fax: +39.030.9839207-208 Internet:www.omfb.it e-mail:contatti@omfb.it

**COMPANY WITH
QUALITY SYSTEM
CERTIFIED BY DNV GL
= IATF 16949 =**

OMFB

HYDRAULIC COMPONENTS

11/05/2021

99760101520 Rev. AD

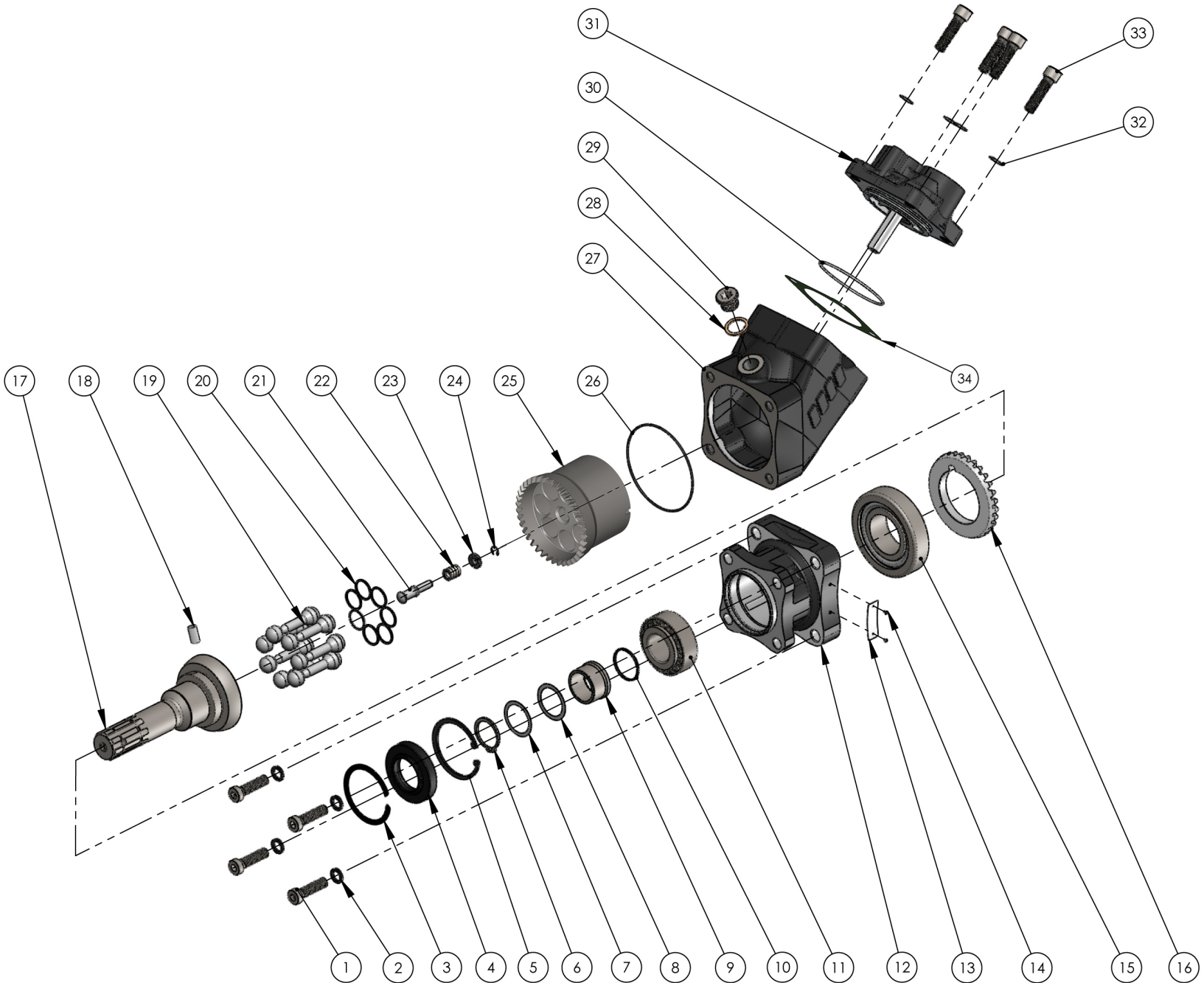



N°	HDS 84		HDS 108		HDS 130		MDS 120		MDS 130		Codice/Code	Descrizione / Description		Q.tà/Q.ty	
	GAS	SAE	GAS	SAE	GAS	SAE	GAS	SAE	GAS	SAE					
1	50200500573	Vite TCE M12x45	Socket head capscrew	4	
2	50102000129	Rosetta elastica	Washer	4	
3	50100002729	Anello elastico	Circlip	1	
4	50600024272	Paraolio	Oil seal	1	
5	50100100677	Anello elastico	Circlip	1	
6	50100001355	Anello seeger rinforzato	Retaining ring	1	
7	52900701127	Rondella	Spacers	2	
8	52900700226	Rondella	Spacers	2	
9	51100200200	Bussola	Bushing	1	
10	50600013137	Guarnizione OR	O-ring	1	
11	51000200364	Cuscinetto a rulli conici	Tapered roller bearing	1	
12	51700201172	Corpo anteriore	Front housing	1	
13	513	Targhetta completa	Plate	1	
14	51300000011	Chiodino fissaggio targhetta	Plate nail	2	
15	51000200355	Cuscinetto a rulli conici	Tapered roller bearing	1	
16	51000200357	Cuscinetto a rulli conici	Tapered roller bearing	1	
17	52501100273	Corona dentata	Crown	1	
18	52200500562	Albero	Shaft	1	
19	52200500955	Spina UNI 6364	Pin UNI 6364	1	
20	50100306142	Pistone sferico	Piston	7	
21	53200500034	Fasce elastiche	Spring rings	21	
22	53200500070	Perno sferico con guida albero	Shaft guide pin	1	
23	53200500105	Molla di carico corpo cilindri	Spring	1	
24	50102300037	Anello guida molla	Spring guide ring	1	
25	50102300117	Anello seeger	Retaining ring	1	
26	50002916084	Gruppo corpo cilindri sede pistoni	Piston barrel assembly	1	
27	50002916108	Guarnizione OR	O-Ring	1	
28	50002916130	Corpo intermedio	Int. housing	1	
29	50600012412	Tappo cieco	Blank plug	1	
30	51700201412	Rondella rame	Copper washer	1	
31	11500600135	Guarnizione OR	O-ring	1	
32	11600910129	Gruppo corpo posteriore	Rear cover assembly	1	
33	50600018520	Rosetta elastica	Washer	4	
34	A	A	A	A	A	A	A	A	A	A	50002990848	Vite TCE M12x45	Socket head capscrew	4	
	A	A	A	A	A	A	A	A	A	A	50002990857	Guarnizione piatta	Gasket	1	
	A	A	A	A	A	A	A	A	A	A	50002991089				
	A	A	A	A	A	A	A	A	A	A	50002991098				
	A	A	A	A	A	A	A	A	A	A	50002991301				
	A	A	A	A	A	A	A	A	A	A	50002991310				
	A	A	A	A	A	A	A	A	A	A	50102000129				
	A	A	A	A	A	A	A	A	A	A	50200500573				
	A	A	A	A	A	A	A	A	A	A	50700000247				
	A	A	A	A	A	A	A	A	A	A	50700000541				

A = alternative

pag. 37

CARATTERISTICHE TECNICHE DI FUNZIONAMENTO / TECHNICAL FEATURES

Tipo pompa Pump type	Cilindrata Displacement cm ³ /rev	Pressione Pressure		Velocità / Speed			Velocità min. Min. speed rpm	Peso Weight kg
		P1 bar	P3 bar	V0 rpm	V1 rpm	V2 rpm		
HDS-84	84.33	350	400	2300	1500	2000	300	19.2
HDS-108	107				1500			18.6
HDS-130	131.62				1750			18.3
MDS-120	122.1	260	280		1500			18.4
MDS-130	131.62	250	270		1500			18.7

P1=Pressione massima continua Max. continuous pressure (100%)
P3=Pressione massima di punta Max. peak pressure (6 sec.max)

V0=Massima continua vuoto Max. continuous speed without load
V1=Massima continua Max. continuous speed
V2=Massima intermittente Max. intermittent speed

PORTATA / FLOW

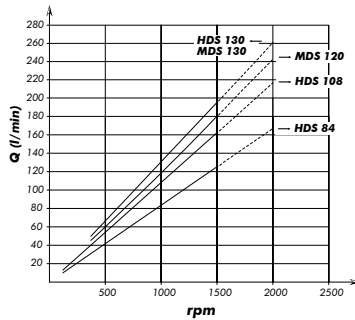

COPPIA ASSORBITA / DRIVE TORQUE

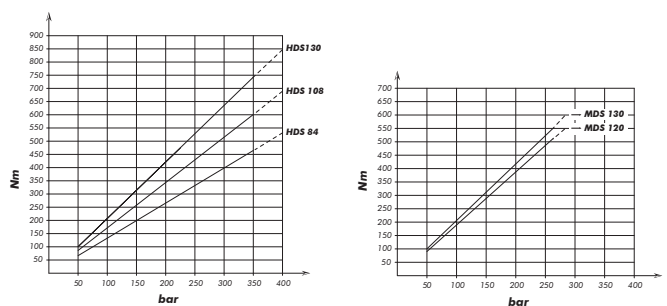

**POTENZA ASSORBITA
POWER INPUT**

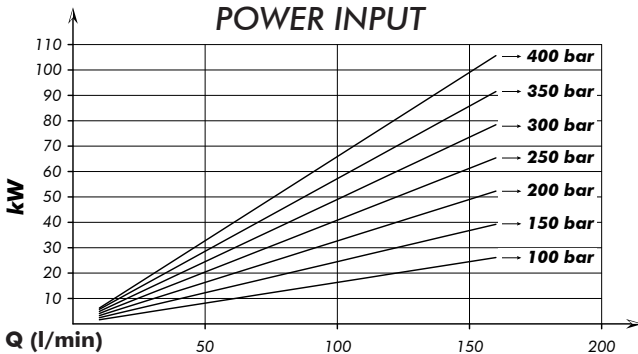

**SCELTA DEL TUBO DI ASPIRAZIONE
HOW TO CHOOSE THE SUCTION PIPE SIZE**

Q Portata Flow l/min	interno min. tubo Min pipe diam. mm inch		Velocità flusso Flow speed (m/s)
20	25	1"	0,68
30	32	1" 1/4	0,62
40	32		0,83
50	38	1" 1/2	0,74
60	38		0,88
70	40	1" 9/16	0,93
80	45	1" 3/4	0,84
90	45		0,94
100	50	2"	0,85
110	50		0,93
120	60	2" 3/8	0,71
130	60		0,77
140	60		0,83
150	60	2" 1/2	0,88
160	63		0,86
170	63		0,91
180	63	0,96	

Per garantire corrette condizioni di aspirazione la velocità del flusso non deve superare 1 m/sec.
To ensure the proper suction pipe size the flow speed should not exceed 1mt/sec.

POMPA SINISTRA
LEFT PUMP

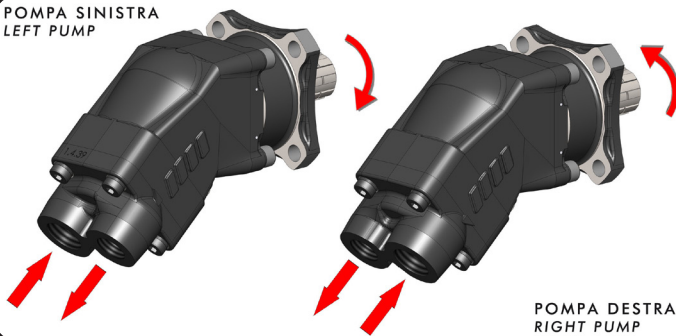

POMPA DESTRA
RIGHT PUMP

Kit guarnizioni / Seal Kit
10890384009

MOMENTO PESO / MASS MOMENT

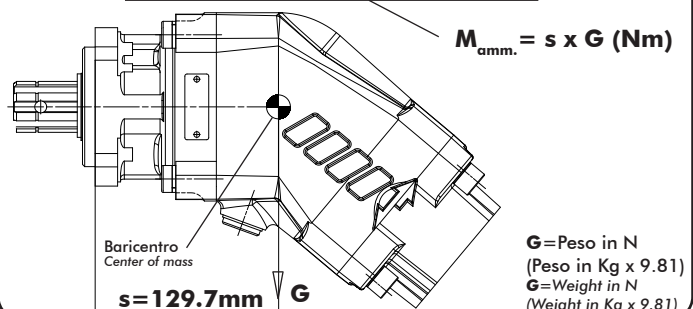

N°	HDS 130	Codice/Code	Descrizione / Description		Q.
1	•	50200500573	Vite TCE M12x45	Socket head capscrew	8
2	•	50102000129	Rosetta elastica	Washer	8
3	•	50100002729	Anello elastico	Circlip	1
4	•	50600024272	Paraolio	Oil seal	1
5	•	50100100677	Anello elastico	Circlip	1
6	•	50100001355	Anello seeger rinforzato	Retaining ring	1
7	•	52900701127	Rondella	Spacers	1
8	•	52900700226	Rondella	Spacers	1
9	•	51100200200	Bussola	Bushing	1
10	•	50600013137	Guarnizione OR	O-ring	1
11	•	51000200364	Cuscinetto a rulli conici	Tapered roller bearing	1
12	•	51700201172	Corpo anteriore	Front housing	1
13	•	513	Targhetta completa	Plate	1
14	•	51300000011	Chiodino fissaggio targhetta	Plate nail	2
15	•	51000200357	Cuscinetto a rulli conici	Tapered roller bearing	1
16	•	52501100273	Corona dentata	Crown	1
17	•	52200500455	Albero	Shaft	1
18	•	50100306142	Spina UNI 6364	Pin UNI 6364	1
19	•	53200500105	Pistone sferico	Piston	7
20	•	50102300117	Fasce elastiche	Spring rings	21
21	•	54200100162	Perno sferico con guida albero	Shaft guide pin	1
22	•	51200500812	Molla di carico corpo cilindri	Spring	1
23	•	54200100171	Anello guida molla	Spring guide ring	1
24	•	50101500028	Anello seeger	Retaining ring	1
25	•	51700300716	Corpo cilindri sede pistoni	Piston barrel	1
26	•	50600012412	Guarnizione OR	O-Ring	1
27	•	51700201412	Corpo intermedio	Int. housing	1
28	•	11500600135	Tappo cieco	Blank plug	1
29	•	11600910129	Rondella rame	Copper washer	1
30	•	50600018520	Guarnizione OR	O-ring	1
31	•	51700202242	Corpo posteriore (sinistro)	Rear cover (left)	1
32	•	53300400328	Boccola DU 16x18x25	Bushing	1
33	•	53300400337	Boccola DU 16x18x20	Bushing	1
34	A	50700000247	Guarnizione piatta 0,3mm	Gasket	1
	A	50700000541	Guarnizione piatta 0,5mm		

A = alternative

CARATTERISTICHE TECNICHE DI FUNZIONAMENTO / TECHNICAL FEATURES

Tipo pompa Pump type	Cilindrata Displacement cm ³ /rev	Pressione Pressure		Velocità / Speed			Velocità min. Min. speed rpm	Peso Weight kg
		P1 bar	P3 bar	V0 rpm	V1 rpm	V2 rpm		
HDS-130	131.62	350	400	2300	1750	2000	300	18,7

P1=Pressione massima continua Max. continuous pressure (100%)
P3=Pressione massima di punta Max. peak pressure (6 sec.max)

V0=Massima continua vuoto Max. continuous speed without load
V1=Massima continua Max. continuous speed
V2=Massima intermittente Max. intermittent speed

PORTATA / FLOW

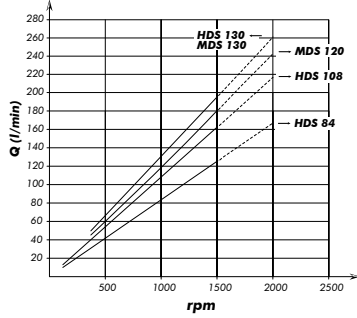

**COPPIA ASSORBITA
DRIVE TORQUE**

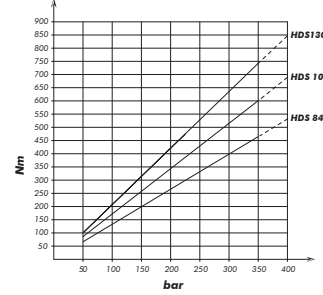

**POTENZA ASSORBITA
POWER INPUT**

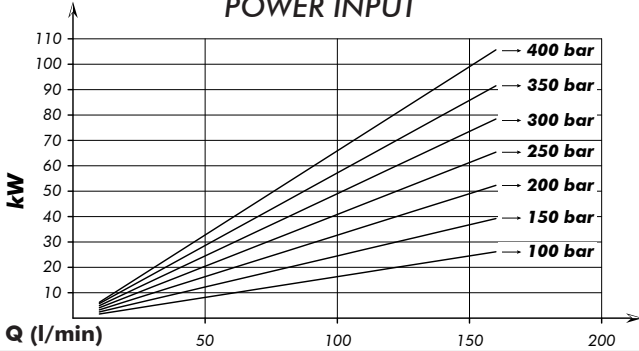

**SCELTA DEL TUBO DI ASPIRAZIONE
HOW TO CHOOSE THE SUCTION PIPE SIZE**

Q Portata Flow l/min	interno min. tubo Min pipe diam.		Velocità flusso Flow speed (m/s)
	mm	inch	
20	25	1"	0,68
30	32	1" 1/4	0,62
40	32		0,83
50	38	1" 1/2	0,74
60	38	1" 9/16	0,88
70	40		0,93
80	45	1" 3/4	0,84
90	45	2"	0,94
100	50		0,85
110	50	2" 3/8	0,93
120	60		0,71
130	60	2" 1/2	0,77
140	60		0,83
150	60	2" 1/2	0,88
160	63		0,86
170	63	2" 1/2	0,91
180	63		0,96

Per garantire corrette condizioni di aspirazione la velocità del flusso non deve superare 1 m/sec.
To ensure the proper suction pipe size the flow speed should not exceed 1m/sec.

POMPA SINISTRA
LEFT PUMP

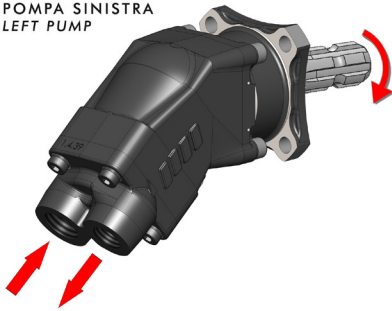

Kit guarnizioni / Seal Kit
10890384009

MOMENTO PESO / MASS MOMENT

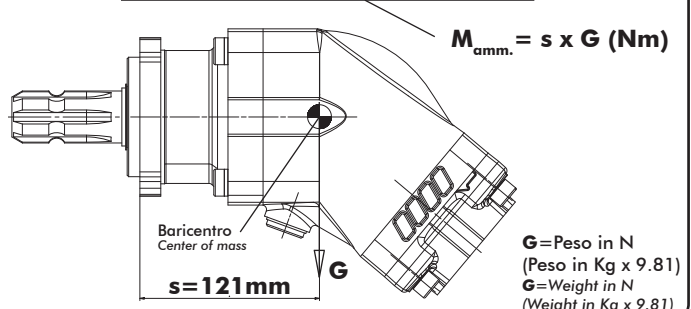

POMPE A PISTONI AD ASSE INCLINATO BENT AXIS PISTON PUMPS

CODICE FAMIGLIA
FAMILY CODE

602001

"HDT"

Flangia/Flange
Albero/Shaft
Cilin./Displ.

ISO
ISO14 8x32x36
75-84-96-108



99740060010

Fluido idraulico Fluid	Minerale o sintetico compatibile con guarnizioni: Mineral or synthetic compatible with the following seals: HNBR				
Temp. consentita Allowed temperature	-40 +140 °C				
Viscosità cinematica consigliata Kinematic viscosity suggested	T media ambiente (°C) Average ambient temp. (°C)	< -40	-40 ÷ 10	10 ÷ 35	> 35
	VG (cSt = mm ² /s)	16	22	32	46
Viscosità cinematica ottimale di esercizio Optimale kinematic viscosity		VG = 10 cSt ÷ 100 cSt			
Viscosità cinematica max consentita all'avviamento Max kinematic viscosity suggested at the start-up		VG = 750 cSt			
Indice di viscosità consigliato Viscosity index suggested		VI > 100			
Grado di filtrazione Oil filtering		> 200 bar: 10 µm < 200 bar: 25 µm			
Pres. di aspirazione Inlet pressure		0,85 ÷ 2 bar assoluti/absolut			
Senso di rotazione Pump rotation		Unidirezionale (Dx o Sx) Unidirectional (Right or Left)			
Verificare che la pompa sia posizionata almeno 100 mm sotto il livello minimo del serbatoio olio. Prima di avviare la pompa effettuare spurgo aria. Verify that pump is, at least, 100 mm under the minimum level of the tank. Before starting the pump bleed the air.					

Dimensions in mm

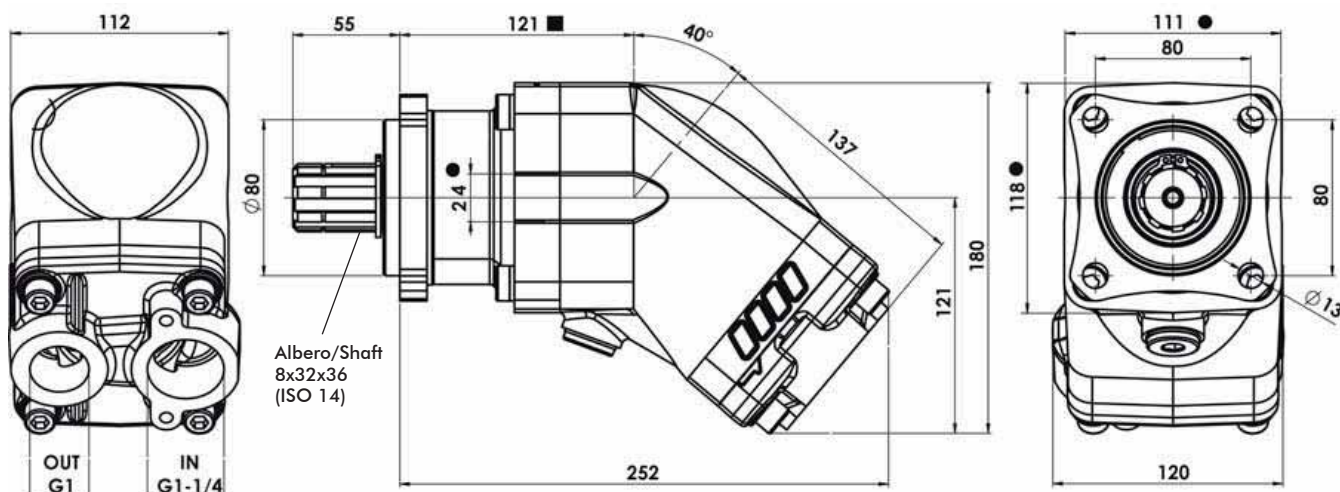

07/03/2017

Tipo pompa Pump type	Rotazione Rotation		IN	OUT
	Destra Right	Sinistra Left		
HDT-75	60200110753	60200110759	ISO 228	ISO 228
HDT-84	60200110843	60200110849	G 1 1/4"	G 1"
HDT-96	60200110963	60200110969		
HDT-108	60200111083	60200111089		
HDT-75	60200150753	60200150759	ISO 725	ISO 725
HDT-84	60200150843	60200150849	1 5/8-12 UN-2B SAE 20	1 5/16-12 UN-2B SAE 16
HDT-96	60200150963	60200150969		
HDT-108	60200151083	60200151089		

99760201301 Rev. AA

pag. 43

OMFB

HYDRAULIC COMPONENTS

O.M.F.B. S.p.A. Hydraulic Components

We reserve the right to make any changes without notice.

Edition 2016.06 No reproduction, however partial, is permitted.

Via Cave, 7/9 25050 Provaglio d'Iseo (Brescia) Italy Tel.: +39.030.9830611
Fax: +39.030.9839207-208 Internet: www.omfb.it e-mail: contatti@omfb.it

COMPANY WITH
QUALITY SYSTEM
CERTIFIED BY DNV GL
= IATF 16949 =



O.M.F.B. S.p.A. Hydraulic Components
 We reserve the right to make any changes without notice.
 Edition 2016.06 No reproduction, however partial, is permitted.
 Via Cove, 719 25050 Poggiole d'Isèo (Brescia) Italy. Tel.: +39 030 9830611
 Fax: +39 030 9839207 208 Internet: www.omfb.it e-mail: conatti@omfb.it

pag. 45

COMPANY WITH
 QUALITY SYSTEM
 CERTIFIED BY DNV GL
 = IATF 16949 =

N°	HDT 75		HDT 84		HDT 96		HDT 108		Codice / Code	Descrizione / Description		Q.
	GAS	SAE	GAS	SAE	GAS	SAE	GAS	SAE				
1	•	•	•	•	•	•	•	•	50200500564	Vite TCE M 12x40	Socket head capscrew	4
2	•	•	•	•	•	•	•	•	50102000129	Rosetta elastica	Washer	4
3	•	•	•	•	•	•	•	•	50100002729	Anello elastico	Circlip	1
4	•	•	•	•	•	•	•	•	50600024272	Paraolio	Oil seal	1
5	•	•	•	•	•	•	•	•	50100100677	Anello elastico	Circlip	1
6	•	•	•	•	•	•	•	•	51000200220	Cuscinetto a rulli conici	Tapered roller bearing	1
7	•	•	•	•	•	•	•	•	51700201707	Corpo anteriore	Front housing	1
8	•	•	•	•	•	•	•	•	50100001355	Anello seeger	Retaining ring	1
9	•	•	•	•	•	•	•	•	52900700226	Rondella	Washer	1
10	•	•	•	•	•	•	•	•	52900701127	Rondella	Washer	1
11	•	•	•	•	•	•	•	•	51100200200	Bussola	Bushing	1
12	•	•	•	•	•	•	•	•	50600013137	Guarnizione OR 3137 HNBR	O-ring 3137 HNBR	1
13	•	•	•	•	•	•	•	•	51000200294	Cuscinetto a rulli conici	Tapered roller bearing	1
14	•	•	•	•	•	•	•	•	52501100282	Corona dentata	Crown	1
15	•	•	•	•	•	•	•	•	50100306142	Spina UNI 6364-A	Pin UNI 6364-A	1
16	•	•	•	•	•	•	•	•	52200500375	Albero	Shaft	1
17	•	•	•	•	•	•	•	•	54200100162	Perno sferico con guida albero	Shaft guide pin	1
18	•	•	•	•	•	•	•	•	51200500812	Molla di carico corpo cilindri	Spring	1
19	•	•	•	•	•	•	•	•	54200100171	Anello guida molla	Spring guide ring	1
20	•	•	•	•	•	•	•	•	50101500028	Anello seeger	Retaining ring	1
21	•	•	•	•	•	•	•	•	53200500294	Pistone sferico	Piston	7
	•	•	•	•	•	•	•	•	53200500034			
	•	•	•	•	•	•	•	•	53200500276			
	•	•	•	•	•	•	•	•	53200500070			
22	•	•	•	•	•	•	•	•	50102300019	Fasce elastiche	Spring rings	21
	•	•	•	•	•	•	•	•	50102300037			
	•	•	•	•	•	•	•	•	50102300091			
	•	•	•	•	•	•	•	•	50102300055			
23	•	•	•	•	•	•	•	•	50002916075	Gruppo corpo cilindri sede pistoni	Piston barrel assembly	1
	•	•	•	•	•	•	•	•	50002916085			
	•	•	•	•	•	•	•	•	50002916096			
	•	•	•	•	•	•	•	•	50002916109			
24	•	•	•	•	•	•	•	•	50600013300	Guarnizione OR 3300 HNBR	O-Ring 3300 HNBR	1
25	•	•	•	•	•	•	•	•	51700201458	Corpo intermedio	Int. housing	1
26	•	•	•	•	•	•	•	•	11600910129	Rondella acciaio/gomma 1/2	Steel/rubber washer 1/243	1
27	•	•	•	•	•	•	•	•	11500600135	Tappo cieco	Blank plug	1
28	A	A	A	A	A	A	A	A	50700000381	Guarnizione piatta	Gasket	1
	A	A	A	A	A	A	A	A	50700000489			
29	•	•	•	•	•	•	•	•	50002980751	Gruppo corpo posteriore	Rear cover assembly	1
	•	•	•	•	•	•	•	•	50002980760			
	•	•	•	•	•	•	•	•	50002980859			
	•	•	•	•	•	•	•	•	50002980868			
	•	•	•	•	•	•	•	•	50002980966			
	•	•	•	•	•	•	•	•	50002980975			
	•	•	•	•	•	•	•	•	50002981107			
•	•	•	•	•	•	•	•	50002981116				
30	•	•	•	•	•	•	•	•	50102000101	Rosetta SCHNORR	SCHNORR Washer	4
31	•	•	•	•	•	•	•	•	50200400574	Vite TCE M10x45	Socket head capscrew	4
32	•	•	•	•	•	•	•	•	50600012387	Guarnizione OR 2387 HNBR	O-ring 2387 HNBR	1

A = alternative

CARATTERISTICHE TECNICHE DI FUNZIONAMENTO / TECHNICAL FEATURES

Tipo pompa Pump type	Cilindrata Displacement cm ³ /rev	Pressione Pressure		Velocità / Speed			Velocità min. Min. speed rpm	Peso Weight kg
		P1 bar	P3 bar	V0 rpm	V1 rpm	V2 rpm		
HDT-75	75,5	350	370	2300	1500	2000	300	14,9
HDT-84	84,2							14,7
HDT-96	95,5							14,7
HDT-108	107							14,5

P1=Pressione massima continua Max. continuous pressure (100%)
P3=Pressione massima di punta Max. peak pressure (6 sec.max)

V0=Massima continua vuoto Max. continuous speed without load
V1=Massima continua Max. continuous speed
V2=Massima intermittente Max. intermittent speed

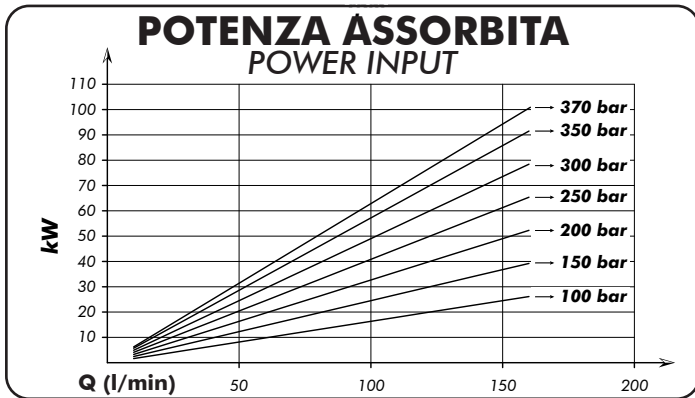
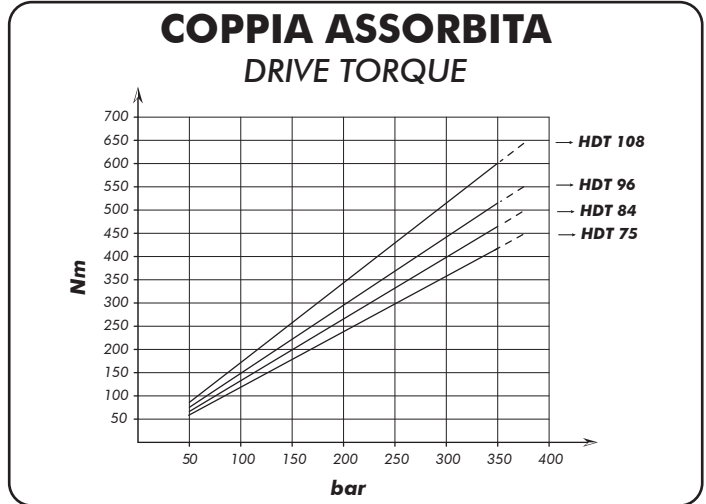
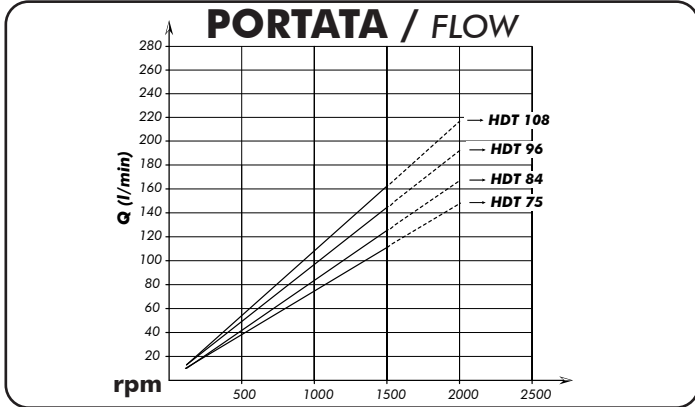

Kit guarnizioni / Seal Kit
10890385008

SCELTA DEL TUBO DI ASPIRAZIONE HOW TO CHOOSE THE SUCTION PIPE SIZE

Q Portata Flow l/min	Ø interno min. tubo Min pipe diam.		Velocità flusso Flow speed (m/s)
	mm	inch	
20	25	1"	0,68
30	32	1" 1/4	0,62
40	32	1" 1/4	0,83
50	38	1" 1/2	0,74
60	38	1" 1/2	0,88
70	40	1" 9/16	0,93
80	45	1" 3/4	0,84
90	45	1" 3/4	0,94
100	50	2"	0,85
110	50	2"	0,93
120	60	2"	0,71
130	60	2" 3/8	0,77
140	60	2" 3/8	0,83
150	60	2" 3/8	0,88
160	63	2" 1/2	0,86
170	63	2" 1/2	0,91
180	63	2" 1/2	0,96

Per garantire corrette condizioni di aspirazione la velocità del flusso non deve superare 1 m/sec.
To ensure the proper suction pipe size the flow speed should not exceed 1mt/sec.

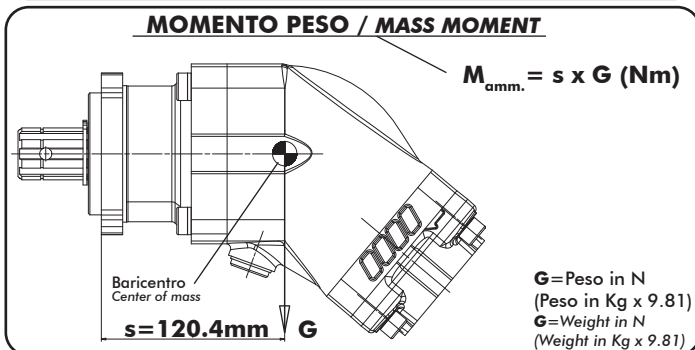
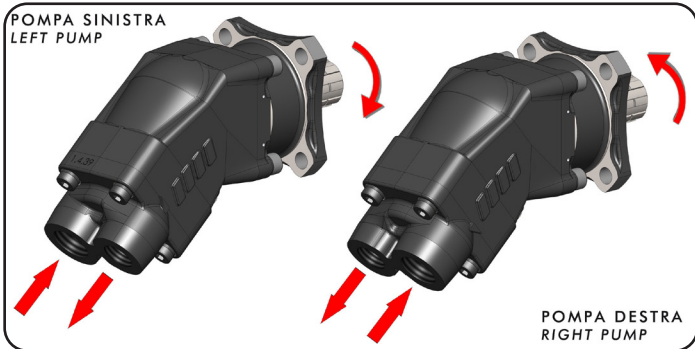

POMPE A PISTONI AD ASSE INCLINATO BENT AXIS PISTON PUMPS

CODICE FAMIGLIA
FAMILY CODE

602003.....F

"HDT"

Flangia/Flange
Albero/Shaft
Cilindrata/Displacement

ISO
ASAE 1"3/8
84-108

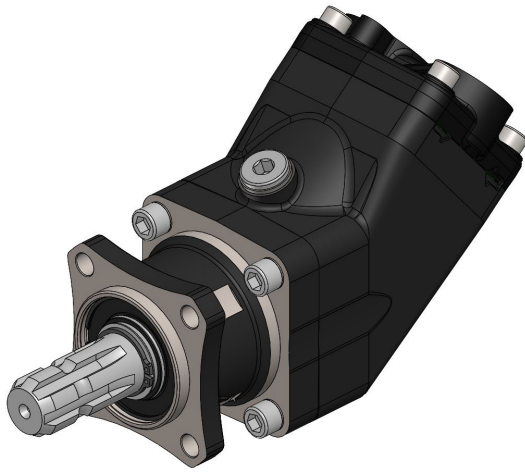

99740060010

Fluido idraulico Fluid	Minerale o sintetico compatibile con guarnizioni: Mineral or synthetic compatible with the following seals: HNBR				
Temp. consentita Allowed temperature	-40 +140 °C				
Viscosità cinematica consigliata Kinematic viscosity suggested	T media ambiente (°C) Average ambient temp. (°C)	< -40	-40 ÷ 10	10 ÷ 35	> 35
	VG (cSt = mm ² /s)	16	22	32	46
Viscosità cinematica ottimale di esercizio Optimale kinematic viscosity		VG= 10 cSt ÷ 100 cSt			
Viscosità cinematica max consentita all'avviamento Max kinematic viscosity suggested at the start-up		VG= 750 cSt			
Indice di viscosità consigliato Viscosity index suggested		VI > 100			
Grado di filtrazione Oil filtering		> 200 bar: 10 µm < 200 bar: 25 µm			
Pres. di aspirazione Inlet pressure		0,85 ÷ 2 bar assoluti/absolut			
Senso di rotazione Pump rotation		Unidirezionale sinistra Unidirectional left			

Verificare che la pompa sia posizionata almeno 100 mm sotto il livello minimo del serbatoio olio. Prima di avviare la pompa effettuare spurgo aria.
Verify that pump is, at least, 100 mm under the minimum level of the tank. Before starting the pump bleed the air.

Dimensions in mm

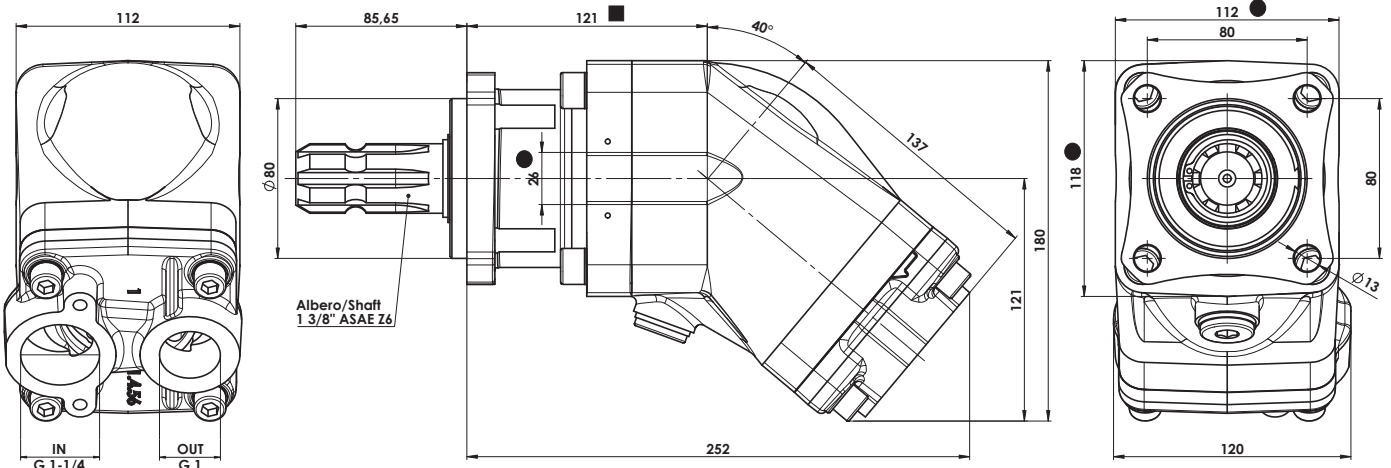

● Larghezza minima corpo a quota indicata ■
Minimum bodywidth at indicated measurement

Tipo pompa Pump type	Rotazione sinistra Left rotation	IN ISO 228	OUT ISO 228
HDT-84	60200310849F	G 1-1/4	G 1
HDT-108	60200311089F		



Nota: la pompa ha senso di rotazione fisso (suffisso F nel codice). Non è possibile invertire il senso di rotazione ruotando il corpo posteriore.

ATTENTION: the pump has fixed sense of rotation (suffix F on part number). It is NOT POSSIBLE to change pump rotation by turning rear-body as in standard version!

31/05/2023

99760200310 Rev. AA

pag.47



O.M.F.B. S.p.A. Hydraulic Components
We reserve the right to make any changes without notice.
Edition 2016.06 No reproduction, however partial, is permitted.
Via Cave, 7/9 25050 Provaglio d'Iseo (Brescia) Italy Tel.: +39.030.9830611
Fax: +39.030.9839207-208 Internet:www.omfb.it e-mail:contatti@omfb.it

COMPANY WITH
QUALITY SYSTEM
CERTIFIED BY DNV GL
= IATF 16949 =

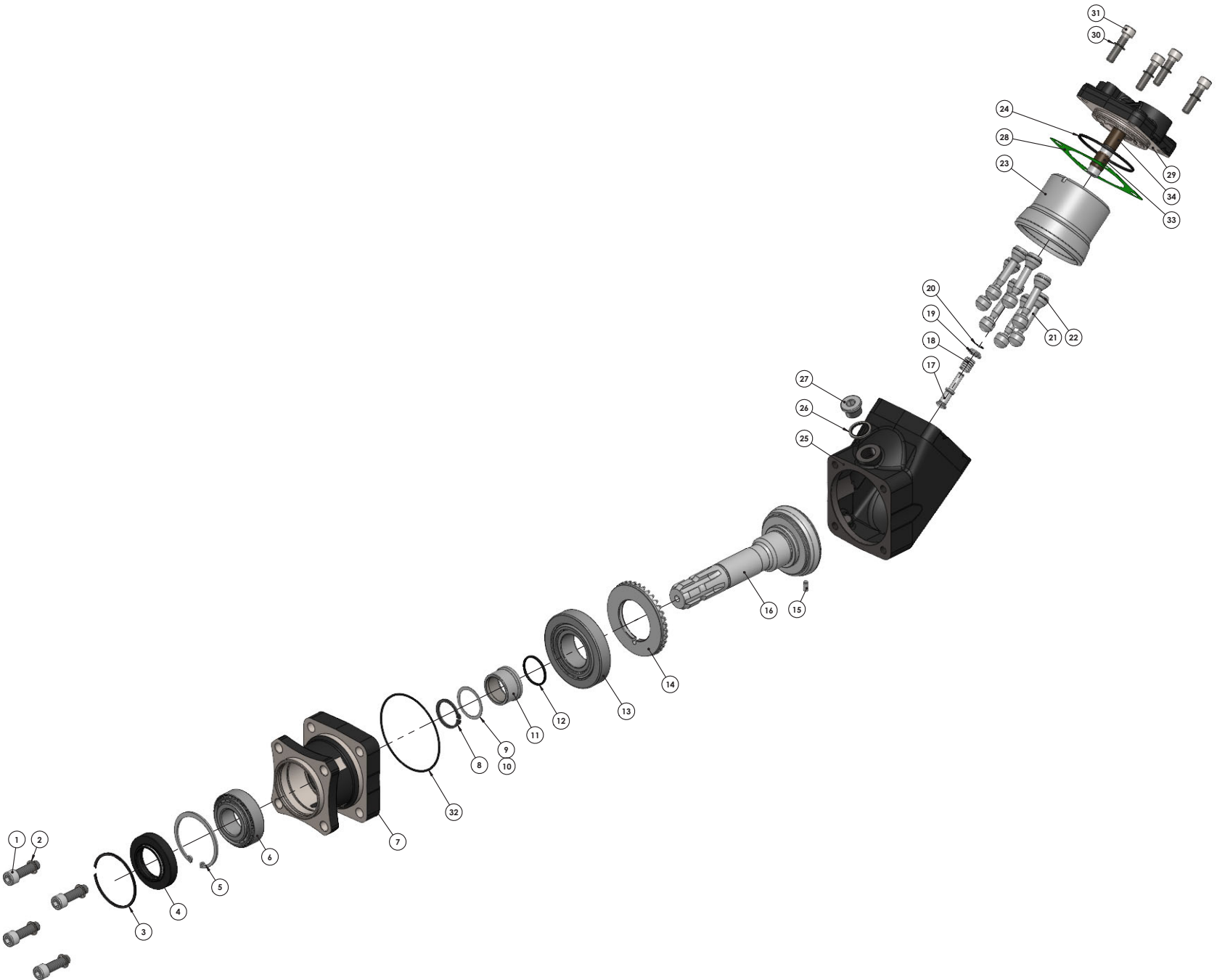

N°	HDT 84	HDT 108	Codice / Code	Descrizione / Description		Q.
1	•	•	50200500564	Vite TCE M 12x40	Socket head capscrew	4
2	•	•	50102000129	Rosetta elastica	Washer	4
3	•	•	50100002729	Anello elastico	Circlip	1
4	•	•	50600024272	Paraolio	Oil seal	1
5	•	•	50100100677	Anello elastico	Circlip	1
6	•	•	51000200220	Cuscinetto a rulli conici	Tapered roller bearing	1
7	•	•	51700201707	Corpo anteriore	Front housing	1
8	•	•	50100001355	Anello seeger	Retaining ring	1
9	•	•	52900700226	Rondella	Washer	1
10	•	•	52900701127	Rondella	Washer	1
11	•	•	51100200200	Bussola	Bushing	1
12	•	•	50600013137	Guarnizione OR 3137 HNBR	O-ring 3137 HNBR	1
13	•	•	51000200294	Cuscinetto a rulli conici	Tapered roller bearing	1
14	•	•	52501100282	Corona dentata	Crown	1
15	•	•	50100306142	Spina UNI 6364-A	Pin UNI 6364-A	1
16	•	•	52200500446	Albero	Shaft	1
17	•	•	54200100162	Perno sferico con guida albero	Shaft guide pin	1
18	•	•	51200500812	Molla di carico corpo cilindri	Spring	1
19	•	•	54200100171	Anello guida molla	Spring guide ring	1
20	•	•	50101500028	Anello seeger	Retaining ring	1
21	•	•	53200500034	Pistone sferico	Piston	7
22	•	•	50102300037	Fasce elastiche	Spring rings	21
23	•	•	51700300734	Gruppo corpo cilindri sede pistoni	Piston barrel assembly	1
24	•	•	50600013300	Guarnizione OR 3300 HNBR	O-Ring 3300 HNBR	1
25	•	•	51700201458	Corpo intermedio	Int. housing	1
26	•	•	11600910129	Rondella acciaio/gomma 1/2	Steel/rubber washer 1/243	1
27	•	•	11500600135	Tappo cieco	Blank plug	1
28	A	A	50700000381	Guarnizione piatta 0,3mm	Gasket	1
	A	A	50700000489	Guarnizione piatta 0,5mm		
29	•	•	50002980877	Gruppo corpo posteriore (sinistro)	Rear cover assembly (left)	1
	•	•	50002981125			
30	•	•	50102000101	Rosetta SCHNORR	SCHNORR Washer	4
31	•	•	50200400574	Vite TCE M10x45	Socket head capscrew	4
32	•	•	50600012387	Guarnizione OR 2387 HNBR	O-ring 2387 HNBR	1
33	•	•	53300400328	Boccola DU 16x18x25	Bushing	1
34	•	•	53300400337	Boccola DU 16x18x20	Bushing	1

A = alternative

CARATTERISTICHE TECNICHE DI FUNZIONAMENTO / TECHNICAL FEATURES

Tipo pompa Pump type	Cilindrata Displacement cm ³ /rev	Pressione Pressure		Velocità / Speed			Velocità min. Min. speed rpm	Peso Weight kg
		P1 bar	P3 bar	V0 rpm	V1 rpm	V2 rpm		
HDT-84	84,2	350	370	2300	1500	2000	300	15
HDT-108	107							

P1=Pressione massima continua Max. continuous pressure (100%)
P3=Pressione massima di punta Max. peak pressure (6 sec.max)

V0=Massima continua vuoto Max. continuous speed without load
V1=Massima continua Max. continuous speed
V2=Massima intermittente Max. intermittent speed

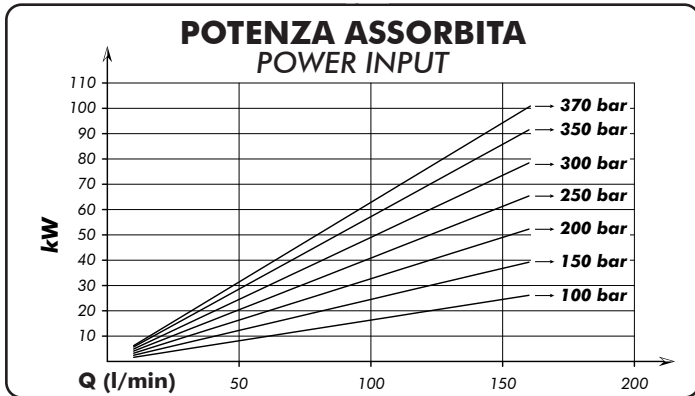
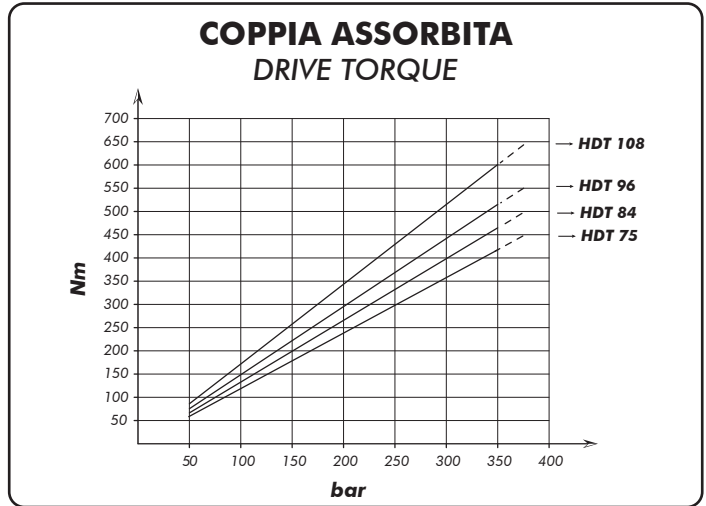
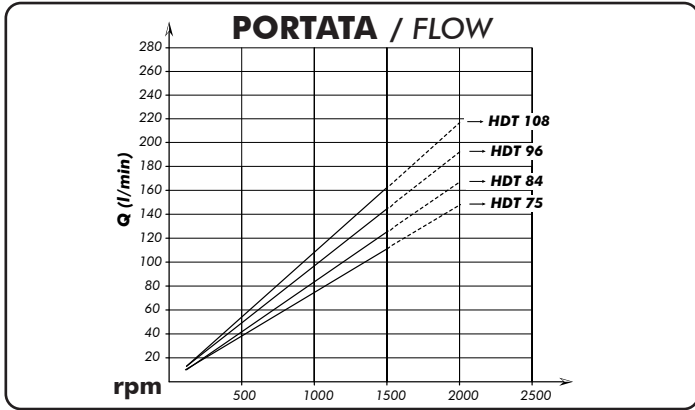

Kit guarnizioni / Seal Kit
10890385008

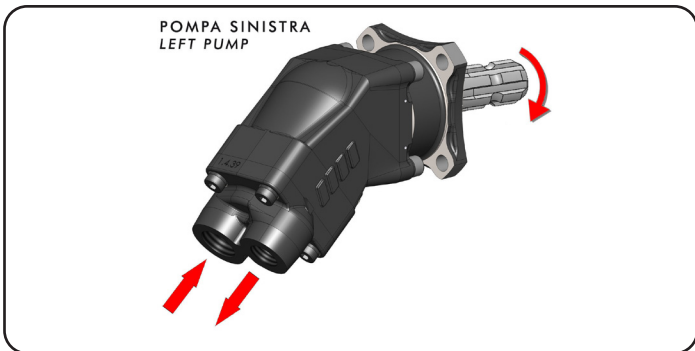

SCELTA DEL TUBO DI ASPIRAZIONE
HOW TO CHOOSE THE SUCTION PIPE SIZE

Q Portata Flow l/min	Ø interno min. tubo Min pipe diam.		Velocità flusso Flow speed (m/s)
	mm	inch	
20	25	1"	0,68
30	32	1" 1/4	0,62
40	32		0,83
50	38	1" 1/2	0,74
60	38		0,88
70	40	1" 9/16	0,93
80	45	1" 3/4	0,84
90	45		0,94
100	50	2"	0,85
110	50		0,93
120	60	2" 3/8	0,71
130	60		0,77
140	60		0,83
150	60		0,88
160	63	2" 1/2	0,86
170	63		0,91
180	63		0,96

Per garantire corrette condizioni di aspirazione la velocità del flusso non deve superare 1 m/sec.
To ensure the proper suction pipe size the flow speed should not exceed 1mt/sec.

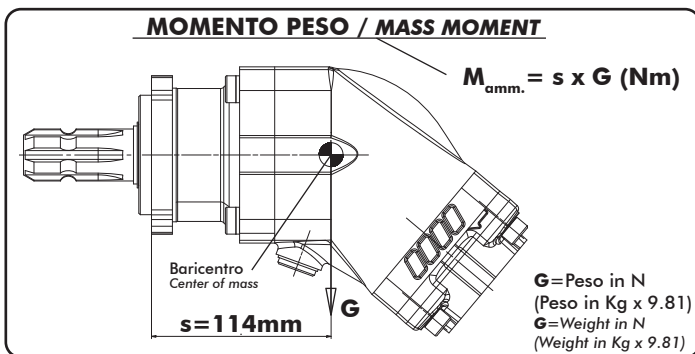



Flangia/Flange ISO
 Albero/Shaft ISO14 8x32x36
 Cilindrata/Displacement vedi tabella/see table

Fluido idraulico / Fluid	Minerale o sintetico compatibile con guarnizioni: Mineral or synthetic compatible with the following seals: FKM, FPM, HNBR				
Viscosità cinematica consigliata Kinematic viscosity suggested	T media ambiente (°C) Average ambient temp. (°C)	< -40	-40÷10	10÷35	> 35
	VG (cSt = mm ² /s)	16	22	32	46
Viscosità cinematica ottimale di esercizio Optimale kinematic viscosity		VG= 10 cSt ÷ 100 cSt			
Viscosità cinematica max consentita all'avviamento Max kinematic viscosity suggested at the start-up		VG= 750 cSt			
Indice di viscosità consigliato Viscosity index suggested	VI > 100	Temperatura di esercizio Working temperature		-40°C ÷ 140°C	
Grado di filtrazione / Oil filtering		> 200 bar: 10 µm / < 200 bar: 25 µm			
Pres. di aspirazione / Inlet pressure		0,85 ÷ 2 bar assoluti/absolut			
Senso di rotazione / Pump rotation		Unidirezionale / Unidirectional			
Verificare che la pompa sia posizionata almeno 100 mm sotto il livello minimo del serbatoio olio. Prima di avviare la pompa effettuare spurgo aria. Verify that pump is, at least, 100 mm under the minimum level of the tank. Before starting the pump bleed the air.					

Ingombro / Dimension 53+35 53+53 70+35 70+53

Pompa destra / Right pump

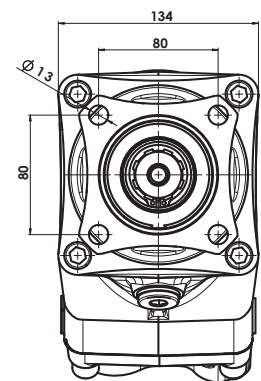
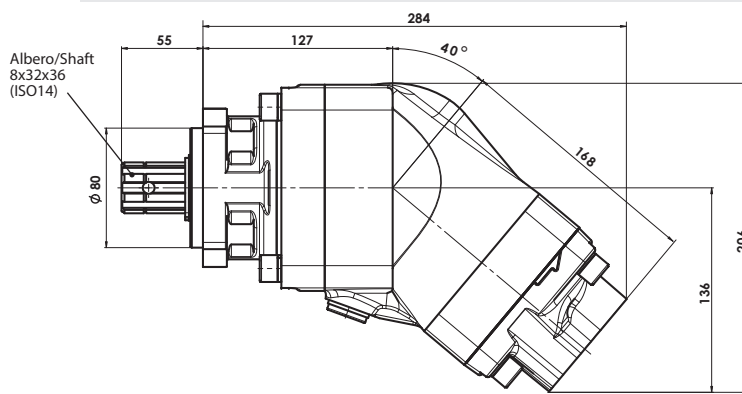
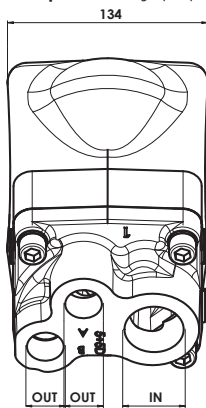

Pompa sinistra / Left pump

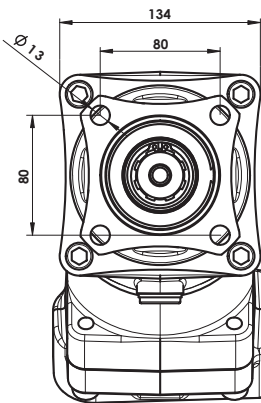
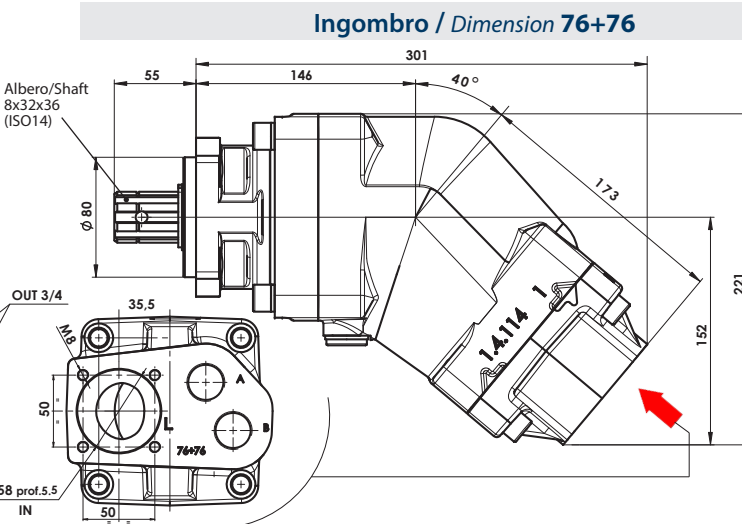
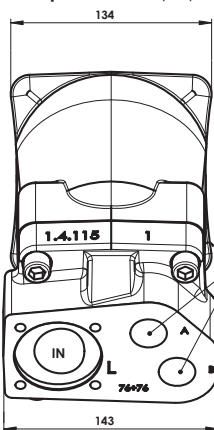

Tipo pompa Pump type	Rotazione Rotation	Codice Code	Gruppo corpo posteriore* Rear cover assembly*	IN ISO 228	OUT ISO 228	Peso Weight
TWIN FLOW 53+35	Destra / Right	60400115033	50002995101	G 1 1/4"	G 3/4"	19,5 kg
	Sinistra / Left	60400115039	50002995209			
TWIN FLOW 53+53	Destra / Right	60400115053	50002995307	G 1 1/4"		20 kg
	Sinistra / Left	60400115059	50002995405			
TWIN FLOW 70+35	Destra / Right	60400117033	50002997001	G 1 1/4"		20,5 kg
	Sinistra / Left	60400117039	50002997109			
TWIN FLOW 70+53	Destra / Right	60400117053	50002997403	G 1 1/2"	21 kg	
	Sinistra / Left	60400117059	50002997501			
TWIN FLOW 76+76	Destra / Right	60400117673	50002997618	Ø58 *	24,5 kg	
	Sinistra / Left	60400117679	50002997609			

* Per modificare il senso di rotazione della pompa, da rotazione DESTRA IN SINISTRA, O VICEVERSA, è necessario sostituire il corpo posteriore.
 * To change the pump rotation, the rear body must be replaced.

Esplso / Spare parts 53+53 70+35 70+53

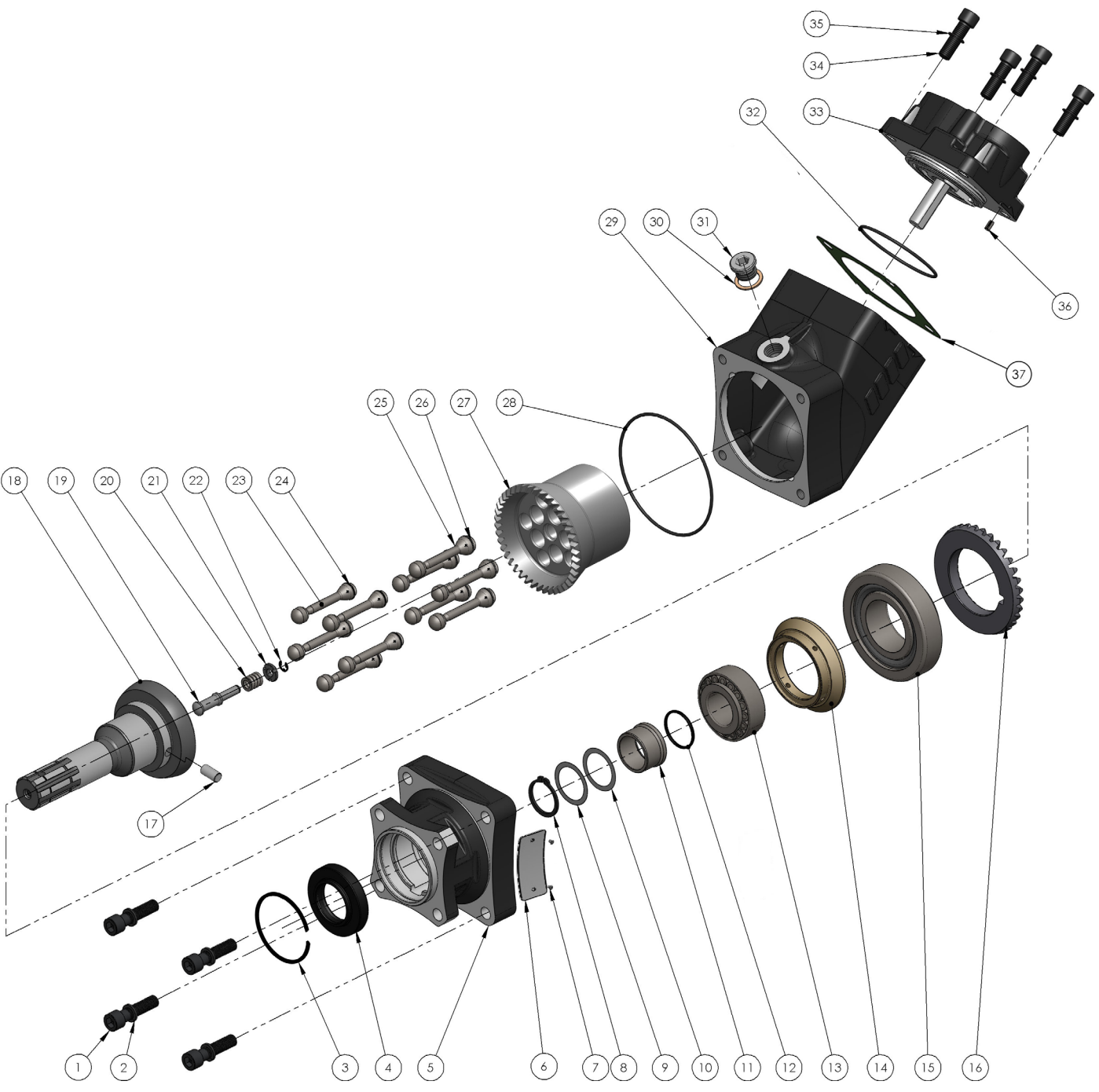

N°	TWIN FLOW 53+53	TWIN FLOW 70+35	TWIN FLOW 70+53	Codice P. Number	Descrizione / Description	Q.	
1	.	.	.	50200500582	Vite TCE M 12x50 UNI 5931	Socket head capscrew M12x50 UNI 5931	4
2	.	.	.	50100800063	Rosetta elastica x M12 DIN 7980	Washer x M12 DIN 7980	4
3	.	.	.	50100002729	Anello elastico E-SB 72x2	Circlip E-SB 72x2	1
4	.	.	.	50600024272	Paraolio HNBR	Oil seal HNBR	1
5	.	.	.	51700201047	Corpo anteriore	Front housing	1
6	.	.	.	513	Targhetta completa	Plate	1
7	.	.	.	51300000011	Chiodino fissaggio targhetta	Plate nail	2
8	.	.	.	50100001355	Anello seeger rinforzato AS 35x2.5 E.UNI 7436	Retaining ring AS 35x2.5 E.UNI 7436	1
9	.	.	.	52900700217	Rondella 45X35X0.1	Washer 45X35X0.1	1
10	.	.	.	52900700226	Rondella 45X35X0.2	Washer 45X35X0.2	1
11	.	.	.	51100200200	Bussola Øi 35	Bushing Øi 35	1
12	.	.	.	50600013137	Guarnizione OR 3137 HNBR	O-Ring 3137 HNBR	1
13	.	.	.	51000200364	Cuscinetto a rulli conici 35x72x28 EUR 33207	Tapered roller bearing 35x72x28 EUR 33207	1
14	.	.	.	53000400271	Anello distanziale cuscinetti	Bearing spacer ring	1
15	.	.	.	51000255115	Cuscinetto a rulli conici 55x115x34 EUR. T7FC055	Tapered roller bearing 55x115x34 EUR. T7FC055	1
16	.	.	.	52501100291	Corona dentata	Crown	1
17	.	.	.	50100308202	Spina UNI 6364-A Ø8x20	Pin UNI 6364-A Ø8x20	1
18	.	.	.	52200500571	Albero	Shaft	1
	.	.	.	52200500599			
	.	.	.	52200500580			
19	.	.	.	54200100304	Perno guida molla	Shaft guide pin	1
20	.	.	.	51200500812	Molla di carico corpo cilindri	Spring	1
21	.	.	.	54200100171	Anello guida molla	Spring guide ring	1
22	.	.	.	50101500028	Anello seeger RS 6 DIN6799	Retaining ring RS 6 DIN6799	1
23	.	.	.	53200500123	Pistone sferico	Piston	5
	.	.	.	53200500258			
	.	.	.	53200500132			
24	.	.	.	50102300126	Fasce elastiche	Spring rings	15
	.	.	.	50102300019			
	.	.	.	50102300037			
25	.	.	.	53200500132	Pistone sferico	Piston	5
	.	.	.	53200500123			
	.	.	.	53200500034			
26	.	.	.	50102300037	Fasce elastiche	Spring rings	15
	.	.	.	50102300126			
	.	.	.	50002916505			
27	.	.	.	50002916703	Gruppo cilindri sede pistoni	Piston barrel assembly	1
	.	.	.	50002916705			
	.	.	.	50600012425			
28	.	.	.	50600012425	Guarnizione ORM 1240-25 HNBR	OR M 1240-25 HNBR	1
29	.	.	.	51700201930	Corpo intermedio	Int. housing	1
30	.	.	.	11600910129	Rondella acciaio/gomma 1/2"	Copper washer 1/2"	1
31	.	.	.	11500600135	Tappo cieco 1/2" DIN 908	Blank plug 1/2" DIN 908	1
32	.	.	.	50600018525	Guarnizione ORM 850-25 HNBR	OR M 850-25 HNBR	1
33	.	.	.	50002995307 DX (Right)	Gruppo corpo posteriore	Rear cover assembly	1
	.	.	.	50002995405 SX (Left)			
	.	.	.	50002997001 DX (Right)			
	.	.	.	50002997109 SX (Left)			
	.	.	.	50002997403 DX (Right)			
34	.	.	.	50002997501 SX (Left)	Vite TCE M 12x45 UNI 5931	Socket head capscrew M12x45 UNI 5931	4
	.	.	.	50200500573			
	.	.	.	50100800063			
35	.	.	.	50100800063	Rosetta elastica x M12 DIN 7980	Washer x M12 DIN 7980	4
36	.	.	.	50100480123	Spina Ø 5X10 UNI 6873	Pin Ø 5X10 UNI 6873	1
37	A	A	A	50700000283	Guarnizione piatta 0,3mm	Gasket 0,3mm	1
	A	A	A	50700000407	Guarnizione piatta 0,5mm	Gasket 0,5mm	

A = alternative

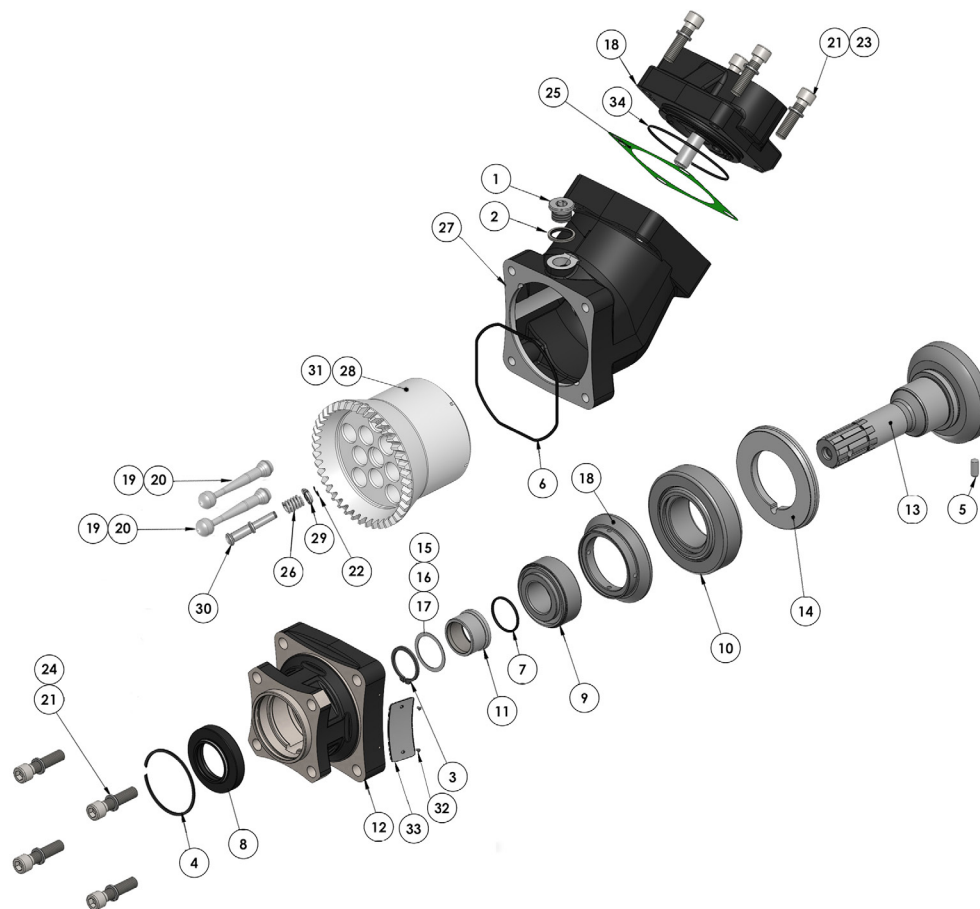
Esploso / Spare parts 53+35

TWIN FLOW 53+35				
N°	Codice / P. Number	Descrizione / Description		Q.
1	11500600135	Tappo cieco 1/2" DIN 908	Blank plug 1/2" DIN 908	1
2	11600910129	Rondella acciaio/gomma 1/2"	Copper washer 1/2"	1
3	50100001355	Anello seeger rinforzato AS 35x2.5 E.UNI 7436	Retaining ring AS 35x2.5 E.UNI 7436	1
4	50100002729	Anello elastico E-SB 72x2	Circlip E-SB 72x2	1
5	50100308202	Spina UNI 6364-A Ø8x20	Pin UNI 6364-A Ø8x20	1
6	50600012425	Guarnizione ORM 1240-25 HNBR	OR M 1240-25 HNBR	1
7	50600013137	Guarnizione OR 3137 HNBR	O-Ring 3137 HNBR	1
8	50600024272	Paraolio HNBR	Oil seal HNBR	1
9	51000200364	Cuscinetto a rulli conici 35x72x28 EUR 33207	Tapered roller bearing 35x72x28 EUR 33207	1
10	51000255115	Cuscinetto a rulli conici 55x115x34 EUR. T7FC055	Tapered roller bearing 55x115x34 EUR. T7FC055	1
11	51100200200	Bussola Øi 35	Bushing Øi 35	1
12	51700201047	Corpo anteriore	Front housing	1
13	52200500580	Albero	Shaft	1
14	52501100291	Corona dentata	Crown	1
15	52900700217	Rondella 45X35X0.1	Washer 45X35X0.1	1
16	52900700226	Rondella 45X35X0.2	Washer 45X35X0.2	1
17	53000400271	Anello distanziale cuscinetti	Bearing spacer ring	1
18	50002995209	Gruppo corpo posteriore SX.	LEFT rear cover assembly	1
	50002995101	Gruppo corpo posteriore DX.	RIGHT rear cover assembly	
19	50102300126	Facce elastiche	Spring rings	30
20	52300500123	Pistone sferico Ø17	Piston	10
21	50100800063	Rosetta elastica x M12 DIN 7980	Washer x M12 DIN 7980	8
22	50101500028	Anello seeger RS 6 DIN6799	Retaining ring RS 6 DIN6799	1
23	50200500573	Vite TCE M 12x45 UNI 5931	Socket head capscrew M12x45 UNI 5931	4
24	50200500582	Vite TCE M 12x50 UNI 5931	Socket head capscrew M12x50 UNI 5931	4
25	A 50700000283	Guarnizione corpo 0.3mm	Gasket 0.3mm	1
	A 50700000407	Guarnizione corpo 0.5mm	Gasket 0.5mm	1
26	51200500812	Molla di carico corpo cilindri	Spring	1
27	51700201930	Corpo intermedio	Int. housing	1
28	51700300887	Gruppo cilindri sede piston	Piston barrel assembly	1
29	54200100171	Anello guida molla	Spring guide ring	1
30	54200100304	Perno guida molla	Shaft guide pin	1
31	53300400337	Boccola DU 16x18x25	Bushing 16x18x25	2
32	51300000011	Chiodino fissaggio targhetta	Plate nail	2
33	513	Targhetta completa	Plate	1
34	50600018525	Guarnizione ORM 850-25 HNBR	OR M 850-25 HNBR	1

A = alternative

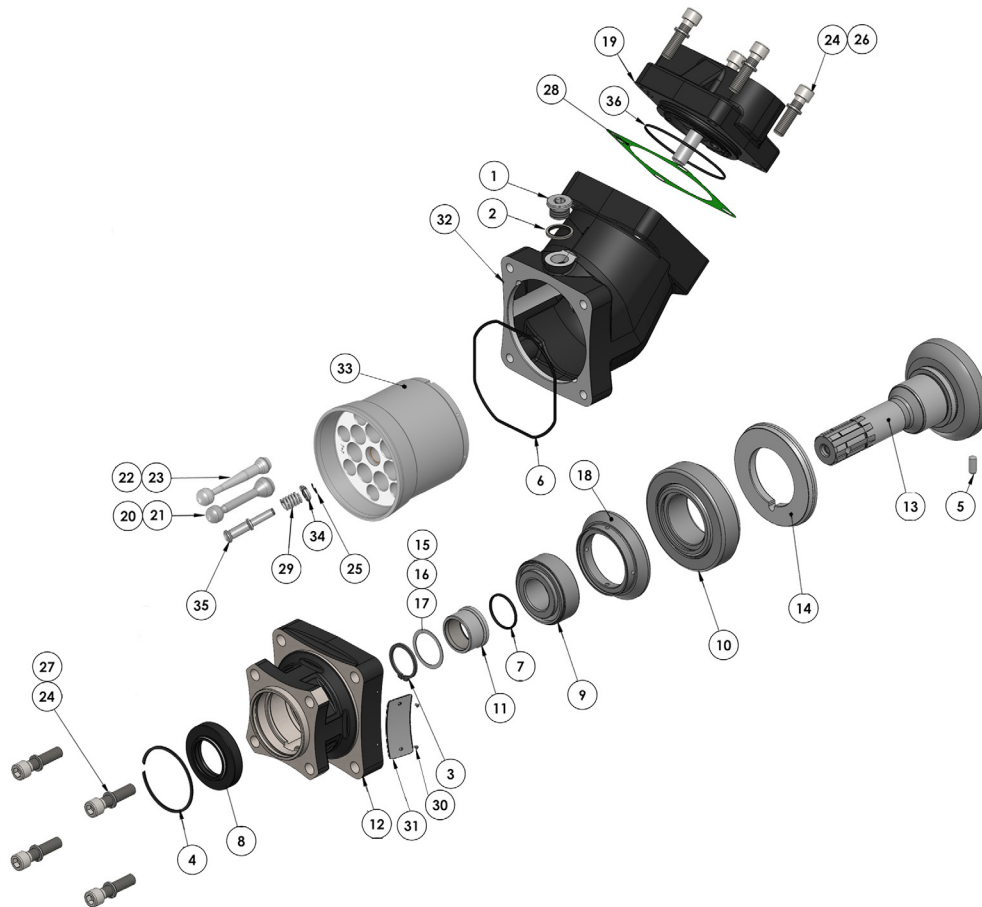
Esploso / Spare parts 76+76

TWIN FLOW 76+76

N°	Codice / P. Number	Descrizione / Description		Q.
1	11500600135	Tappo cieco 1/2" DIN 908	Blank plug 1/2" DIN 908	1
2	11600910129	Rondella acciaio/gomma 1/2"	Copper washer 1/2"	1
3	50100001355	Anello seeger rinforzato AS 35x2.5 E.UNI 7436	Retaining ring AS 35x2.5 E.UNI 7436	1
4	50100002729	Anello elastico E-SB 72x2	Circlip E-SB 72x2	1
5	50100308202	Spina UNI 6364-A Ø8x20	Pin UNI 6364-A Ø8x20	1
6	50600012425	Guarnizione ORM 1240-25 HNBR	OR M 1240-25 HNBR	1
7	50600013137	Guarnizione OR 3137 HNBR	O-Ring 3137 HNBR	1
8	50600024272	Paraolio HNBR	Oil seal HNBR	1
9	51000200364	Cuscinetto a rulli conici 35x72x28 EUR 33207	Tapered roller bearing 35x72x28 EUR 33207	1
10	51000255115	Cuscinetto a rulli conici 55x115x34 EUR. T7FC055	Tapered roller bearing 55x115x34 EUR. T7FC055	1
11	51100200200	Bussola Øi 35	Bushing Øi 35	1
12	51700201047	Corpo anteriore	Front housing	1
13	52200500839	Albero	Shaft	1
14	52501100291	Corona dentata	Crown	1
15	52900700217	Rondella 45X35X0.1	Washer 45X35X0.1	1
16	52900700226	Rondella 45X35X0.2	Washer 45X35X0.2	1
17	52900701449	Rondella speciale	Special washer	1
18	53000400271	Anello distanziale cuscinetti	Bearing spacer ring	1
19	50002997609	Gruppo corpo posteriore SX.	LEFT rear cover assembly	1
	50002997618	Gruppo corpo posteriore DX.	RIGHT rear cover assembly	
20	50102300037	Fasce elastiche	Spring rings	21
21	53200500132	Pistone sferico Ø19	Piston	7
22	50102300046	Fasce elastiche	Spring rings	21
23	53200500310	Pistone sferico Ø15,5	Piston	7
24	50100800063	Rosetta elastica x M12 DIN 7980	Washer x M12 DIN 7980	8
25	50101500028	Anello seeger RS 6 DIN6799	Retaining ring RS 6 DIN6799	1
26	50200500573	Vite TCE M 12x45 UNI 5931	Socket head capscrew M12x45 UNI 5931	4
27	50200500582	Vite TCE M 12x50 UNI 5931	Socket head capscrew M12x50 UNI 5931	4
28	A 50700000612	Guarnizione corpo 0.3mm	Gasket 0.3mm	1
	A 50700000621	Guarnizione corpo 0.5mm	Gasket 0.5mm	1
29	51200500812	Molla di carico corpo cilindri	Spring	1
30	51300000011	Chiodino fissaggio targhetta	Plate nail	2
31	513	Targhetta completa	Plate	1
32	51700201958	Corpo intermedio	Int. housing	1
33	50002916767	Gruppo cilindri sede pistoncini	Piston barrel assembly	1
34	54200100171	Anello guida molla	Spring guide ring	1
35	54200100304	Perno guida molla	Shaft guide pin	1
36	50600019622	Guarnizione ORM 0960-20 HNBR	OR M 0960-20 HNBR	1

A = alternative

Raccordi validi SOLO per Twinflow 76+76 / Fittings suitable for Twinflow 76+76 ONLY

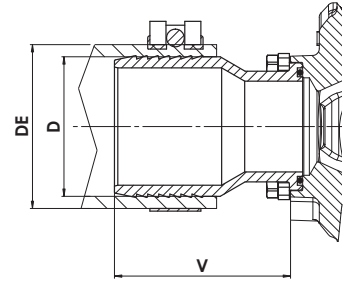
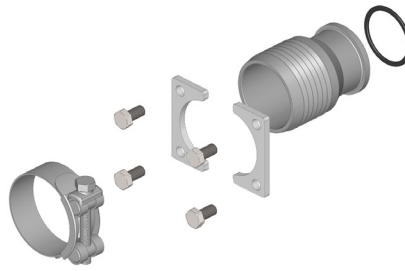
Codice Code	D	DE	V	Peso Weigth
	mm	mm	mm	Kg
15511200507	50	60-63	59	0,59
15511200516	50	64-67	59	0,6
15511200605	60	68-73	79	0,77
15511200632	63	74-79	79	0,8
15511200767	76	86-91	94	1



Codice Code	D	DE	Z	Peso Weigth
	mm	mm	mm	Kg
15511245639	63	74-79	163	1,75
15511245764	76	86-91	167	2,1

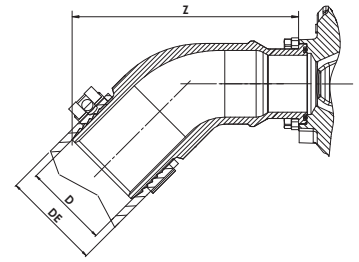
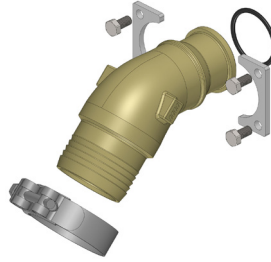

Codice Code	D	DE	V	Z	Peso Weigth
	mm	mm	mm	mm	Kg
15511290634	63	74-79	103	139	1,9
15511290769	76	86-91	103	140	2,3

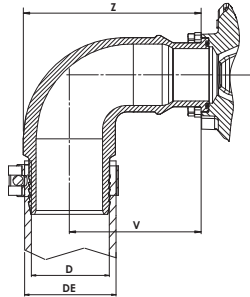

15511300408

Kit flangia foro filettato G1-1/2, per montaggio raccordi GOLD.
Flange kit G1-1/2 threaded hole, for mounting GOLD fittings.

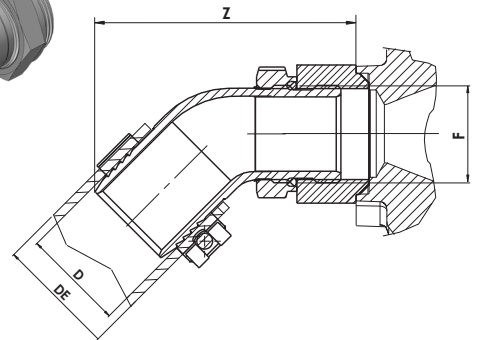
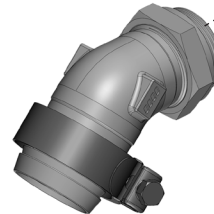
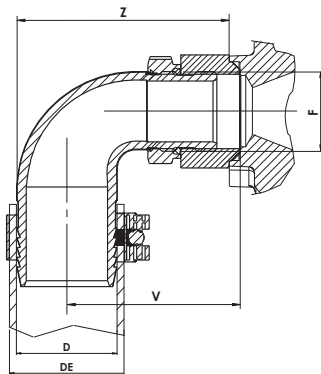

Codice Code	F	D	DE	V	Z	Peso Weigth
	ISO 228	mm	mm	mm	mm	Kg
15510000592	G1-1/2	50	60-63	85	114	0,99
15510000609			64-67			1
15510000654		60	68-73	88	123	1,06

Codice Code	F	D	DE	Z	Peso Weigth
	ISO 228	mm	mm	mm	Kg
15509000540	G1-1/2	50	60-63	133	0,79
15509000559			64-67		0,82
15509000611		60	68-73	153	1

Caratteristiche tecniche funzionamento Technical features		53+35	53+53	70+35	70+53	76+76
Cilindrata A / Displacement (cc/rev)		36,5	53	36,5	53	75,1
Cilindrata B / Displacement (cc/rev)		55	55	68,3	66,2	74,8
Pressione massima continua / Max. continuous pressure (bar)		350	350	350	300	300
Pressione massima picco / Max. peak pressure (bar)		400	400	400	350	350
Velocità massima a vuoto / Max. speed without load (rpm)		2550	2550	2550	2550	2550
Velocità massima con uscita A e B in press. Max. speed with load on A and B outputs (*)		1800	1800	1800	1650	1500
Velocità massima con 1 porta in press. Max. speed with load on 1 output only (*)		2100	2100	2100	2100	2100
Potenza massima continua / Max. continuous power (kW)		94	111	108	98	110
Potenza massima intermittente / Max. intermittent power (kW)		107	127	123	114	129

Pressione massima continua Max. continuous pressure (100%)
 Pressione massima di punta Max. peak pressure (6 sec.max)

(*) Velocità con tubo diam. interno 63mm (2"1/2) minimo.
 Speed with pipe internal diameter 63mm (2"1/2) minimum.

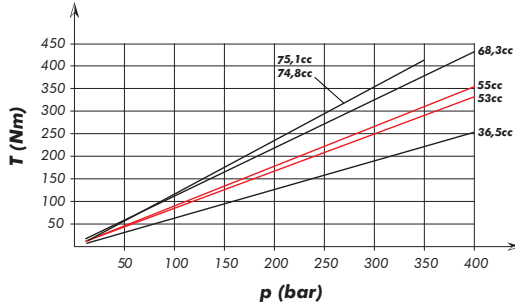
Coppia teorica assorbita / Theoretical drive torque

La coppia assorbita dalla pompa deve essere calcolata come somma delle coppie necessarie per mandare in pressione le 2 mandate.
 The total torque absorbed by the pump is given by the sum of the torques necessary to give pressure to the pressure ports.

Potenza teorica assorbita / Theoretical power input

La potenza totale è pari alla somma delle potenze richieste dai singoli utilizzi sulle 2 mandate.
 The total power absorbed by the pump is given by the sum of the power required by the two pressure ports.

$$P_{TOT} = P_A + P_B = \frac{(p_A \cdot Q_A + p_B \cdot Q_B)}{612}$$

P [kW]
 Q [l/min]
 p [bar]

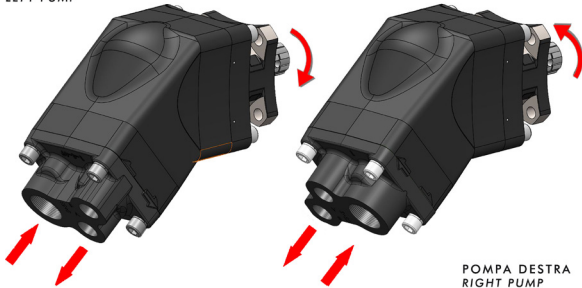
 POMPA SINISTRA
 LEFT PUMP

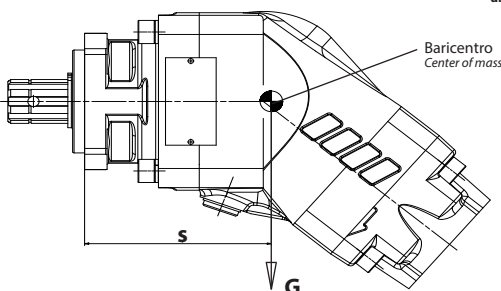
 POMPA DESTRA
 RIGHT PUMP

Momento peso / Mass moment $M_{amm.} = s \times G$ (Nm)

G=Peso in N
 (Peso in Kg x 9.81)
 G=Weight in N
 (Weight in Kg x 9.81)

Pompa 53+53 e 70+35: con tubo diam. interno 50mm (2") velocità max. 1200rpm.
 Pump 53+53 and 70+35: with pipe internal diameter 50mm (2") max. speed 1200rpm.

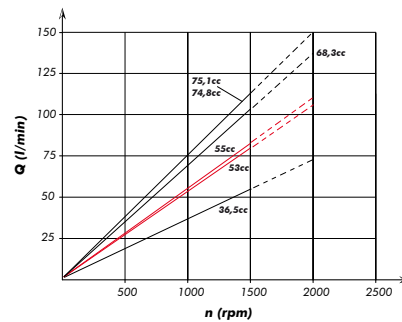
Pompa 70+53: solo con tubo diam. interno 63mm (2"1/2).
 Pump 70+53: only with pipe internal diameter 63mm (2"1/2).

Portata teorica / Theoretical flow

La portata della pompa è pari alla somma delle portate delle 2 mandate.
 The total pump flow is given by the sum of the flow of each pressure port.

Sceita del tubo di aspirazione

How to choose the suction pipe size

Q Portata Flow	Ø interno min. tubo Minimum pipe diameter		Velocità flusso Flow speed
l/min	mm	inch	(m/s)
30	32	1" 1/4	0,62
40	32	1" 1/4	0,83
50	38	1" 1/2	0,74
60	38	1" 1/2	0,88
70	40	1" 9/16	0,93
80	45	1" 3/4	0,84
90	45	1" 3/4	0,94
100	50	2"	0,85
110	50	2"	0,93
120	60	2" 3/8	0,71
130	60	2" 3/8	0,77
140	60	2" 3/8	0,83
160	63	2" 1/2	0,86
170	63	2" 1/2	0,91
180	63	2" 1/2	0,96

Per garantire corrette condizioni di aspirazione la velocità del flusso non deve superare 1m/sec.
 To ensure the proper suction pipe size the flow speed should not exceed 1mt/sec.

Kit guarnizioni / Seal Kit

	S	
53+35	126,2	10890353533
53+53	125,9	
70+35	126	10890376769
70+53	127,1	
76+76	143	

POMPE A PISTONI AD ASSE INCLINATO

BENT AXIS PISTON PUMPS

CODICE FAMIGLIA
FAMILY CODE

606002

"HDS"

Flangia/Flange
Albero/Shaft
Cilin./Displ.

UNI
ISO14 6x21x25
40-47-55-64

99740060010

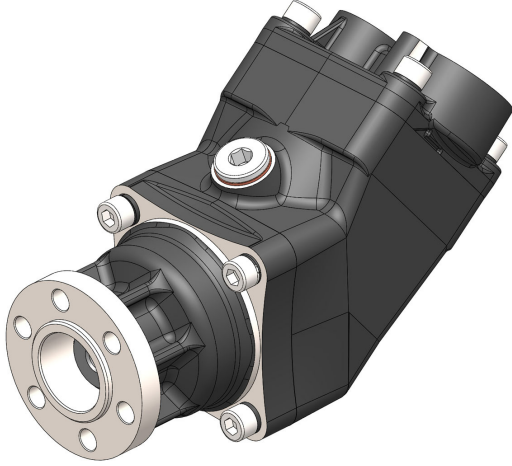

Fluido idraulico Fluid	Minerale o sintetico compatibile con guarnizioni: Mineral or synthetic compatible with the following seals: FKM, FPM, HNBR				
Viscosità cinematica consigliata Kinematic viscosity suggested	T media ambiente (°C) Average ambient temp. (°C)	< -40	-40 ÷ 10	10 ÷ 35	> 35
	VG (cSt = mm ² /s)	16	22	32	46
Viscosità cinematica ottimale di esercizio Optimale kinematic viscosity			VG = 10 cSt ÷ 100 cSt		
Viscosità cinematica max consentita all'avviamento Max kinematic viscosity suggested at the start-up			VG = 750 cSt		
Indice di viscosità consigliato Viscosity index suggested	VI > 100	Temperatura di esercizio Working temperature -15°C ÷ 140°C			
Grado di filtrazione Oil filtering		> 200 bar: 10 µm < 200 bar: 25 µm			
Pres. di aspirazione Inlet pressure		0,85 ÷ 2 bar assoluti/absolut			
Senso di rotazione Pump rotation		Unidirezionale (Dx o Sx) Unidirectional (Right or Left)			
Verificare che la pompa sia posizionata almeno 100 mm sotto il livello minimo del serbatoio olio. Prima di avviare la pompa effettuare spurgo aria. Verify that pump is, at least, 100 mm under the minimum level of the tank. Before starting the pump bleed the air.					

30/03/2016

Dimensions in mm

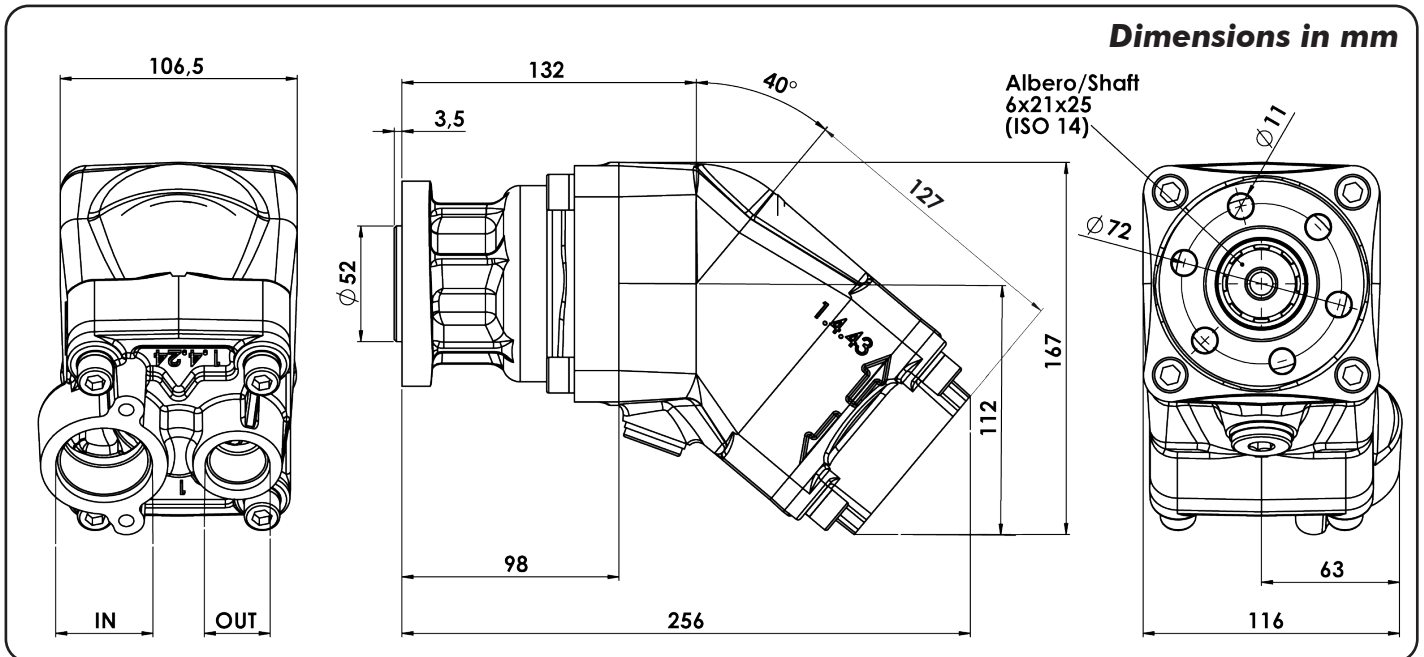

99760601410 Rev. //

Tipo pompa Pump type	Rotazione Rotation		IN	OUT	IN	OUT
	Destra Right	Sinistra Left				
HDS-40	60600210403	60600210409	G 1 1/4"	G 3/4"	SAE	SAE
HDS-47	60600210473	60600210479				
HDS-55	60600210553	60600210559				
HDS-64	60600210643	60600210649				

pag.59

O.M.F.B. S.p.A. Hydraulic Components

We reserve the right to make any changes without notice.

Edition 2016.06 No reproduction, however partial, is permitted.

Via Cave, 7/9 25050 Provaglio d'Iseo (Brescia) Italy Tel.: +39.030.9830611
Fax: +39.030.9839207-208 Internet:www.omfb.it e-mail:contatti@omfb.it

**COMPANY WITH
QUALITY SYSTEM
CERTIFIED BY DNV GL
= IATF 16949 =**



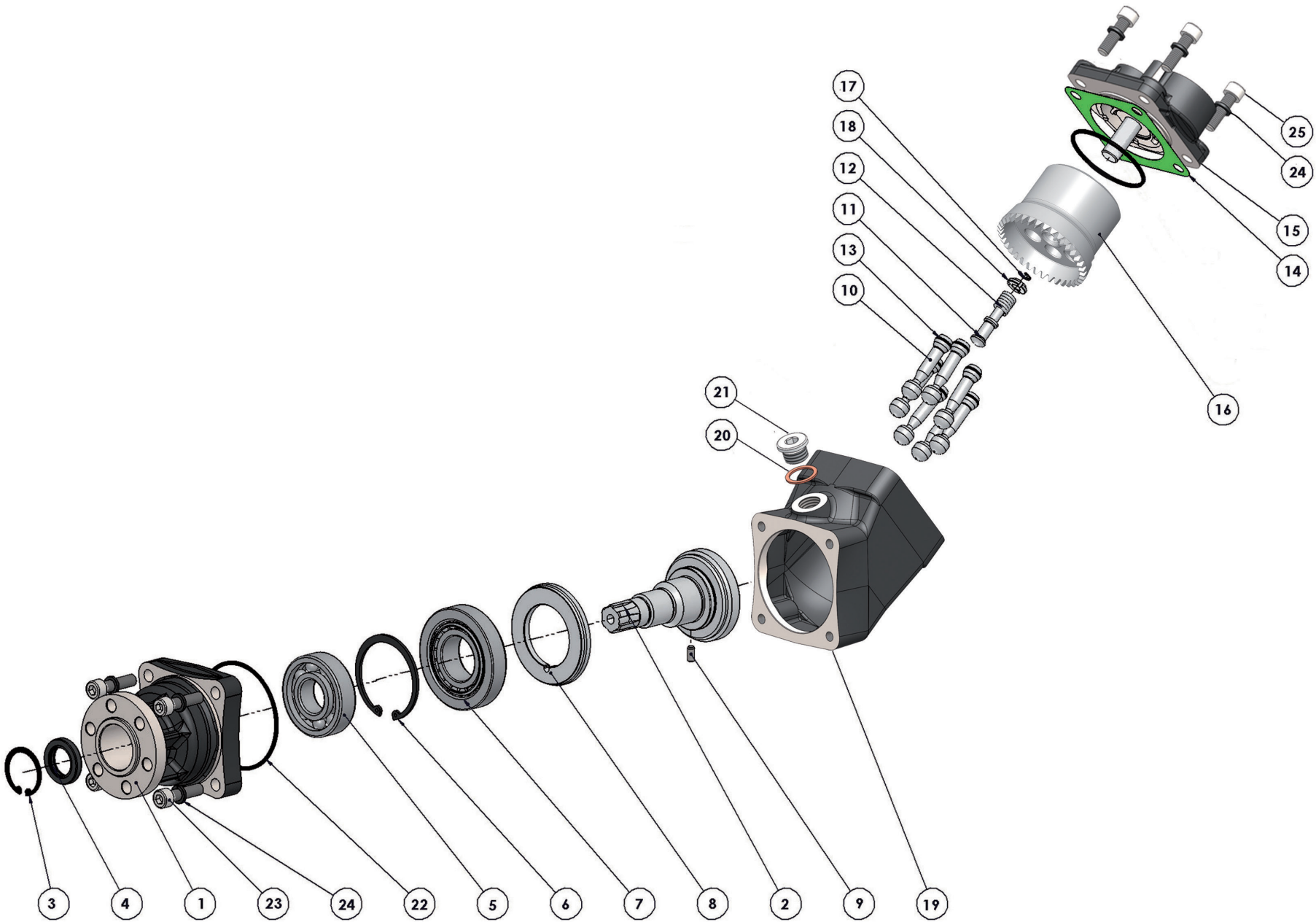

pag. 60

COMPANY WITH

QUALITY SYSTEM

CERTIFIED BY DNV GL

= IATF 16949 =

O.M.F.B. S.p.A. Hydraulic Components

We reserve the right to make any changes without notice.

Edition 2016.06 No reproduction, however partial, is permitted.

Via Cava, 7/9 25050 Prouglio d'Isco (Brescia) Italy Tel.: +39 030.9830611

Fax: +39 030.9839207-208 Internet:www.omfb.it e-mail:comtatt@omfb.it

OMFB[®]

HYDRAULIC COMPONENTS



O.M.F.B. S.p.A. Hydraulic Components
 We reserve the right to make any changes without notice.
 Edizione 2016.06 No reproduction, however partial, is permitted.
 Via Cove, 719 25050 Povungolo di Isèo (Brescia) Italy Tel.: +39 030 9830611
 Fax: +39 030 9839207/208 Internet: www.omfb.it e-mail: conthi@omfb.it

pag. 61

COMPANY WITH
 QUALITY SYSTEM
 CERTIFIED BY DNV GL
 = IATF-16949 =

N°	HDS 40	HDS 47	HDS 55	HDS 64	Codice P. Number	Descrizione Description	Q.
1	•	•	•	•	51700201752	Corpo anteriore Front housing	1
2	•	•	•	•	52200500400	Albero Shaft	1
3	•	•	•	•	50100100373	Anello seeger 40I Seeger 40I	1
4	•	•	•	•	50602425401	Paraolio GAP 25x40x7 Oil seal GAP 25x40x7	1
5	•	•	•	•	51000100221	Cuscinetto a sfere Ball bearing	1
6	•	•	•	•	50100100677	Anello seeger 72I Seeger 72I	1
7	•	•	•	•	51000200275	Cuscinetto a rulli conici Tapered roller bearing	1
8	•	•	•	•	52501100255	Corona dentata Crown	1
9	•	•	•	•	50100306142	Spina UNI 6364-A Ø6x14 Pin UNI 6364-A Ø6x14	1
10	•				53200500285	Pistone sferico Piston	7
		•			53200500025		
			•		53200500114		
				•	53200500016		
11	•	•	•	•	54200100162	Perno sferico con guida albero Shaft guide pin	1
12	•	•	•	•	51200500812	Molla di carico corpo cilindri Spring	1
13	•				50102300064	Fasce elastiche Spring rings	21
		•			50102300046		
			•		50102300126		
				•	50102300019		
14	A	A	A	A	50700000229	Guarnizione piatta Gasket	1
	A	A	A	A	50700000532		
15	•				50002990400	Gruppo corpo posteriore Rear cover assembly	1
		•			50002990473		
			•		50002990553		
				•	50002990642		
16	•				50002916040	Gruppo corpo cilindri sede pistoni Piston barrel assembly	1
		•			50002916047		
			•		50002916055		
				•	50002916064		
17	•	•	•	•	50101500028	Anello seeger RS 6 DIN 6799 Retaining ring RS 6 DIN 6799	1
18	•	•	•	•	54200100171	Anello guida molla Spring guide ring	1
19	•	•	•	•	51700201421	Corpo intermedio Interm. housing	1
20	•	•	•	•	11600910129	Rondella acciaio/gomma 1/2" Washer 1/2"	1
21	•	•	•	•	11500600135	Tappo cieco 1/2" DIN 908 Blank plug 1/2" DIN 908	
22	•	•	•	•	50600013350	Guarnizione OR 3350 HNBR O-Ring 3350 HNBR	1
23	•	•	•	•	50200400574	Vite TCE M 10x40 UNI 5931 Socket head capscrew M 10x40 UNI 5931	4
24	•	•	•	•	50100800054	Rosetta elastica x M10 DIN 7980 Washer x M10 DIN 7980	8
25	•	•	•	•	50200400565	Vite TCE M10x35 UNI 5931 Socket head capscrew M10x30 UNI 5931	4

A = alternative

CARATTERISTICHE TECNICHE DI FUNZIONAMENTO / TECHNICAL FEATURES

Tipo pompa Pump type	Cilindrata Displacement cm ³ /rev	Pressione Pressure		Velocità / Speed			Velocità min. Min. speed rpm	Peso Weight kg
		P1 bar	P3 bar	V0 rpm	V1 rpm	V2 rpm		
HDS-40	41.25	350	400	2700	1900	2500	300	11,6
HDS-47	47.13							11,7
HDS-55	56.70	320	340					11,6
HDS-64	63.56	280	300					11,5

P1=Pressione max.continua Max. continuous pressure (100%)
P3=Pressione max. di punta Max. peak pressure (6 sec.max)

V0=Massima continua vuoto Max. continuous speed without load
V1=Massima continua Max. continuous speed
V2=Massima intermittente Max. intermittent speed

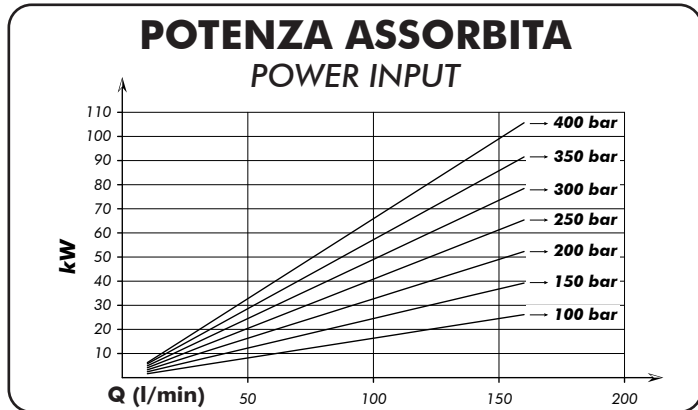
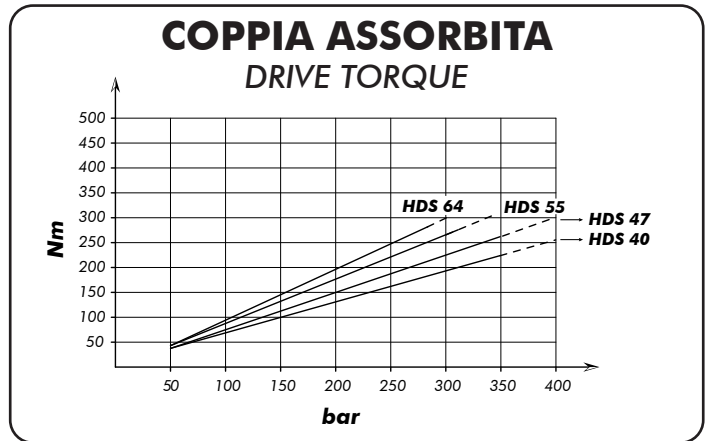
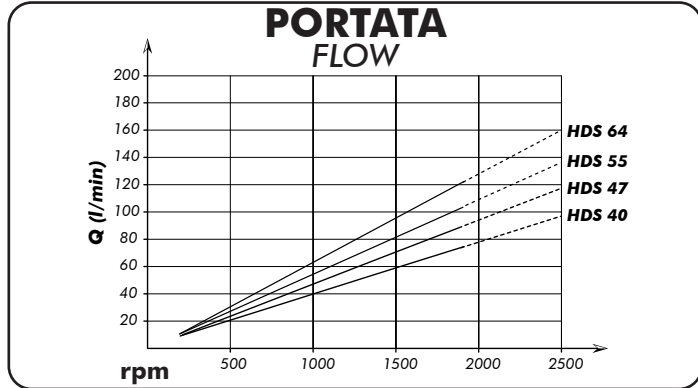

SCELTA DEL TUBO DI ASPIRAZIONE HOW TO CHOOSE THE SUCTION PIPE SIZE

Q Portata Flow l/min	Ø interno min. tubo Min pipe diam.		Velocità flusso Flow speed (m/s)
	mm	inch	
20	25	1"	0,68
30	32	1" 1/4	0,62
40	32	1" 1/4	0,83
50	38	1" 1/2	0,74
60	38	1" 1/2	0,88
70	40	1" 9/16	0,93
80	45	1" 3/4	0,84
90	45	1" 3/4	0,94
100	50	2"	0,85
110	50	2"	0,93
120	60	2"	0,71
130	60	2" 3/8	0,77
140	60	2" 3/8	0,83
150	60	2" 3/8	0,88
160	63	2" 1/2	0,86
170	63	2" 1/2	0,91
180	63	2" 1/2	0,96

Per garantire corrette condizioni di aspirazione la velocità del flusso non deve superare 1 m/sec.
To ensure the proper suction pipe size the flow speed should not exceed 1mt/sec.

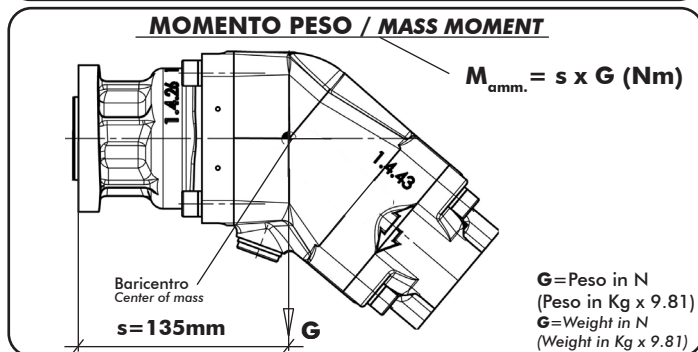
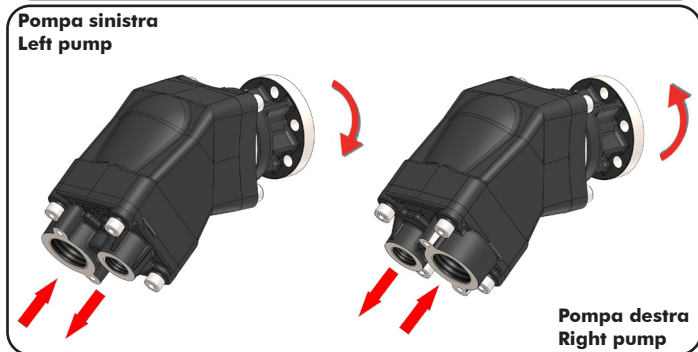

POMPE A PISTONI AD ASSE INCLINATO

BENT AXIS PISTON PUMPS

CODICE FAMIGLIA
FAMILY CODE

606002

"HDS"

Flangia/Flange
Albero/Shaft
Cilin./Displ.

UNI
ISO14 6x21x25
12-17-25-34



99740060010

Fluido idraulico Fluid	Minerale o sintetico compatibile con guarnizioni: Mineral or synthetic compatible with the following seals: FKM, FPM, HNBR				
Viscosità cinematica consigliata Kinematic viscosity suggested	T media ambiente (°C) Average ambient temp. (°C)	< -40	-40 ÷ 10	10 ÷ 35	> 35
	VG (cSt = mm ² /s)	16	22	32	46
Viscosità cinematica ottimale di esercizio Optimale kinematic viscosity		VG = 10 cSt ÷ 100 cSt			
Viscosità cinematica max consentita all'avviamento Max kinematic viscosity suggested at the start-up		VG = 750 cSt			
Indice di viscosità consigliato Viscosity index suggested	VI > 100	Temperatura di esercizio Working temperature -15°C ÷ 140°C			
Grado di filtrazione Oil filtering		> 200 bar: 10 µm < 200 bar: 25 µm			
Pres. di aspirazione Inlet pressure		0,85 ÷ 2 bar assoluti/absolut			
Senso di rotazione Pump rotation		Unidirezionale (Dx o Sx) Unidirectional (Right or Left)			
Verificare che la pompa sia posizionata almeno 100 mm sotto il livello minimo del serbatoio olio. Prima di avviare la pompa effettuare spurgo aria. Verify that pump is, at least, 100 mm under the minimum level of the tank. Before starting the pump bleed the air.					

Dimensions in mm

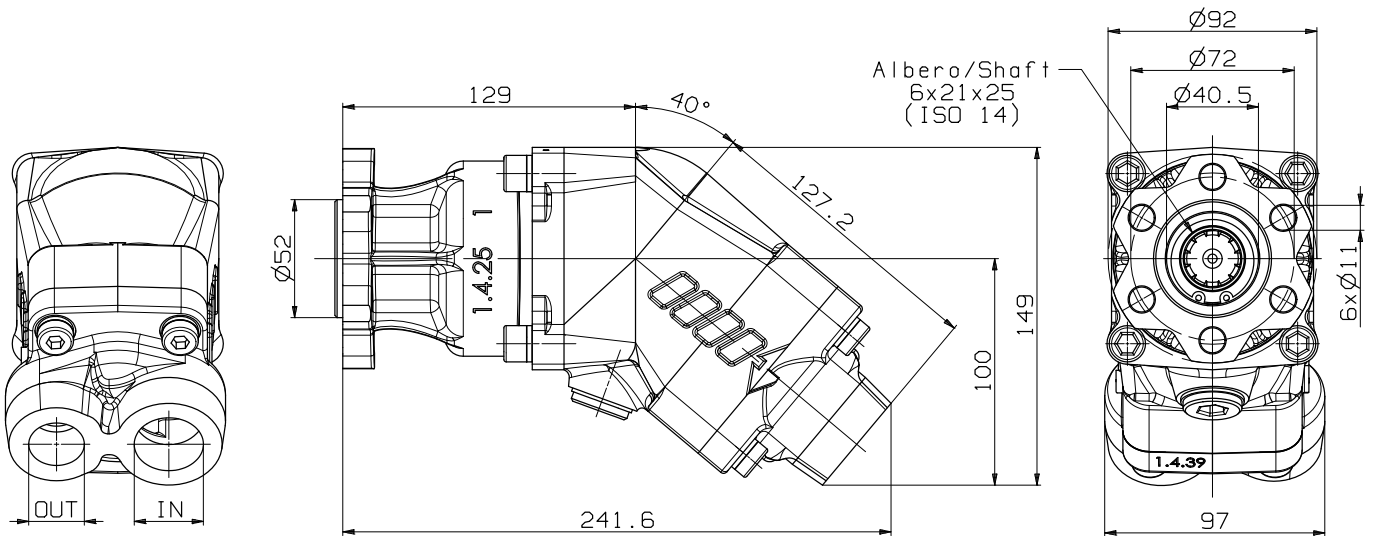

30/03/2016

Tipo pompa Pump type	Rotazione Rotation		IN	OUT	IN	OUT
	Destra Right	Sinistra Left				
HDS-12	60600210123	60600210129	G 1	G 3/4	SAE	SAE
HDS-17	60600210173	60600210179				
HDS-25	60600210253	60600210259				
HDS-34	60600210343	60600210349				

99760601505 Rev. //

pag.63

O.M.F.B. S.p.A. Hydraulic Components

We reserve the right to make any changes without notice.

Edition 2016.06 No reproduction, however partial, is permitted.

Via Cave, 7/9 25050 Provatigo d'Iseo (Brescia) Italy Tel.: +39.030.9830611
Fax: +39.030.9839207-208 Internet:www.omfb.it e-mail:contatti@omfb.it

**COMPANY WITH
QUALITY SYSTEM
CERTIFIED BY DNV GL
= IATF 16949 =**



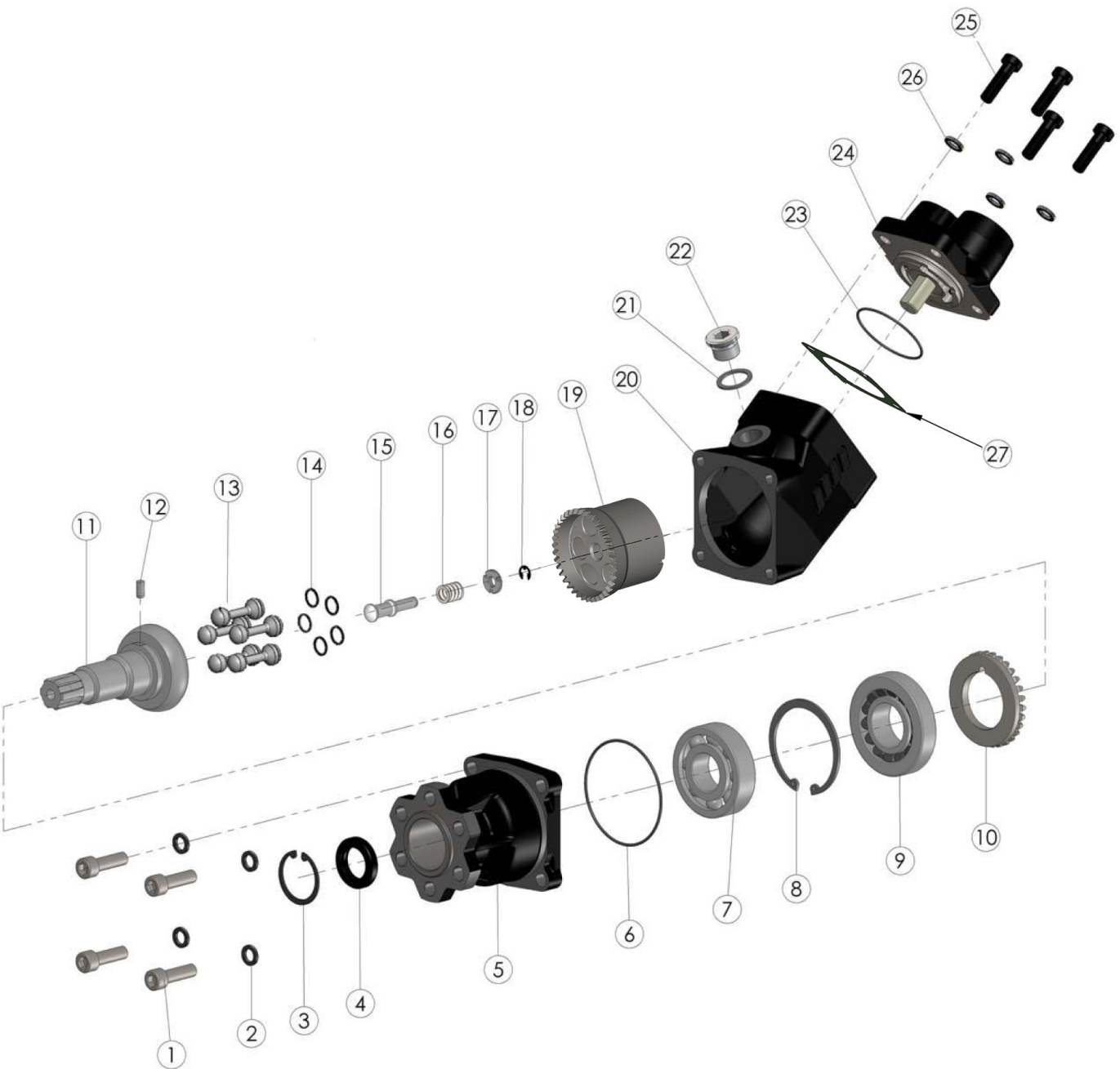

pag. 64

COMPANY WITH
QUALITY SYSTEM

CERTIFIED BY DNV GL

= IATF 16949 =

O.M.F.B. S.p.A. Hydraulic Components

We reserve the right to make any changes without notice.

Edition 2016.06 No reproduction, however partial, is permitted.

Via Cava, 7/9 25050 Provedolo d'Isco (Brescia) Italy Tel.: +39 030.9830611

Fax: +39.030.9839207-208 Internet:www.omfb.it e-mail:contatti@omfb.it



N° N°	HDS 12 GAS	HDS 17 GAS	Codice P. Number	Descrizione Description		Quantità Quantity
1	•	•	50200400565	Vite TCE M 10x35	Socket head capscrew	4
2	•	•	50100800054	Rosetta elastica	Washer	8
3	•	•	50100100373	Anello elastico	Retaining ring	1
4	•	•	50602425411	Paraolio	Oil seal	1
5	•	•	51700201181	Corpo anteriore	Front housing	1
6	•	•	50600018020	Guarnizione	Gasket	1
7	•	•	51000100221	Cuscinetto a sfere	Ball bearing	1
8	•	•	50100100677	Anello seeger	Retaining ring	1
9	•	•	51000200373	Cuscinetto a rulli conici	Tapered roller bearing	1
10	•	•	52501100264	Corona dentata	Crown	1
11	•	•	52200500366	Albero	Shaft	1
12	•	•	50100306142	Spina UNI 6364	Pin UNI 6364	1
13	•		53200500052	Pistone sferico	Piston	5
		•	53200500061			
14	•		50102300073	Fasce elastiche	Spring rings	15
		•	50102300064			
15	•	•	54200100313	Perno sferico con guida albero	Shaft guide pin	1
16	•	•	51200501651	Molla di carico corpo cilindri	Spring	1
17	•	•	54200100322	Anello guida molla	Spring guide ring	1
18	•	•	50101500046	Anello seeger	Retaining ring	1
19	•		50002916012	Gruppo corpo cilindri sede pistoni	Piston barrel assembly	1
		•	50002916017			
20	•	•	51700200717	Corpo intermedio	Int. housing	1
21	•	•	11600910129	Rondella rame	Copper washer	1
22	•	•	11500600135	Tappo cieco	Blank plug	1
23	•	•	50600012224	Guarnizione OR	O-ring	1
24	•		50002980126	Gruppo corpo posteriore	Rear cover assembly	1
		•	50002980171			
25	•	•	50200400556	Vite TCE M10x30	Socket head capscrew	4
26	•	•	50102000101	Rosetta SCHNORR	SCHNORR Washer	4
27	A	A	50700000256	Guarnizione piatta	Gasket	1
	A	A	50700000523			

A = alternative

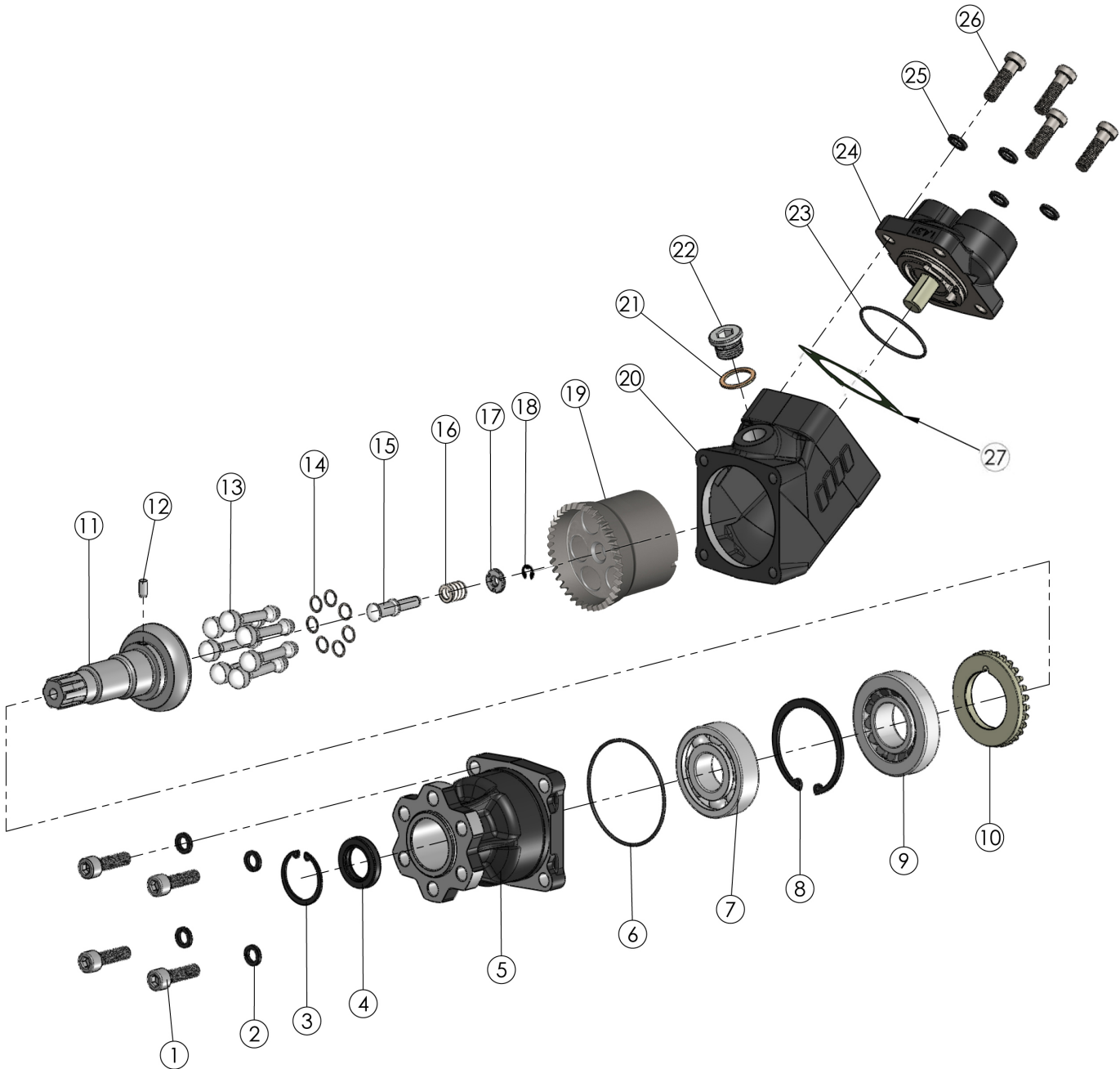



N° N°	HDS 25 GAS	HDS 34 GAS	Codice P. Number	Descrizione Description		Quantità Quantity
1	•	•	50200400565	Vite TCE M 10x35	Socket head capscrew	4
2	•	•	50100800054	Rosetta elastica	Washer	4
3	•	•	50100100373	Anello elastico	Retaining ring	1
4	•	•	50602425411	Paraolio	Oil seal	1
5	•	•	51700201181	Corpo anteriore	Front housing	1
6	•	•	50600018020	Guarnizione	Gasket	1
7	•	•	51000100221	Cuscinetto a sfere	Ball bearing	1
8	•	•	50100100677	Anello seeger	Retaining ring	1
9	•	•	51000200373	Cuscinetto a rulli conici	Tapered roller bearing	1
10	•	•	52501100264	Corona dentata	Crown	1
11	•	•	52200500348	Albero	Shaft	1
12	•	•	50100306142	Spina UNI 6364	Pin UNI 6364	1
13	•	•	53200500052	Pistone sferico	Piston	7
	•	•	53200500061			
14	•	•	50102300073	Fasce elastiche	Spring rings	21
	•	•	50102300064			
15	•	•	54200100162	Perno sferico con guida albero	Shaft guide pin	1
16	•	•	51200500812	Molla di carico corpo cilindri	Spring	1
17	•	•	54200100171	Anello guida molla	Spring guide ring	1
18	•	•	50101500028	Anello seeger	Retaining ring	1
19	•	•	50002916025	Gruppo corpo cilindri sede pistoni	Piston barrel assembly	1
	•	•	50002916034			
20	•	•	51700200717	Corpo intermedio	Int. housing	1
21	•	•	11600910129	Rondella rame	Copper washer	1
22	•	•	11500600135	Tappo cieco	Blank plug	1
23	•	•	50600012224	Guarnizione OR	O-ring	1
24	•	•	50002980251	Gruppo corpo posteriore	Rear cover assembly	1
	•	•	50002980340			
25	•	•	50102000101	Rosetta SCHNORR	SCHNORR Washer	4
26	•	•	50200400556	Vite TCE M10x30	Socket head capscrew	4
27	A	A	50700000256	Guarnizione piatta	Gasket	1
	A	A	50700000523			

A = alternative

CARATTERISTICHE TECNICHE DI FUNZIONAMENTO / TECHNICAL FEATURES

Tipo pompa Pump type	Cilindrata Displacement cm ³ /rev	Pressione Pressure		Velocità / Speed			Velocità min. Min. speed rpm	Peso Weight kg
		P1 bar	P3 bar	V0 rpm	V1 rpm	V2 rpm		
HDS-12	12.62	350	400	3000	2300	3000	300	8,3
HDS-17	16.98							8,3
HDS-25	25.12							8,4
HDS-34	33.80							8,3

P1=Pressione massima continua Max. continuous pressure (100%)
P3=Pressione massima di punta Max. peak pressure (6 sec.max)

V0=Massima continua vuoto Max. continuous speed without load
V1=Massima continua Max. continuous speed
V2=Massima intermittente Max. intermittent speed

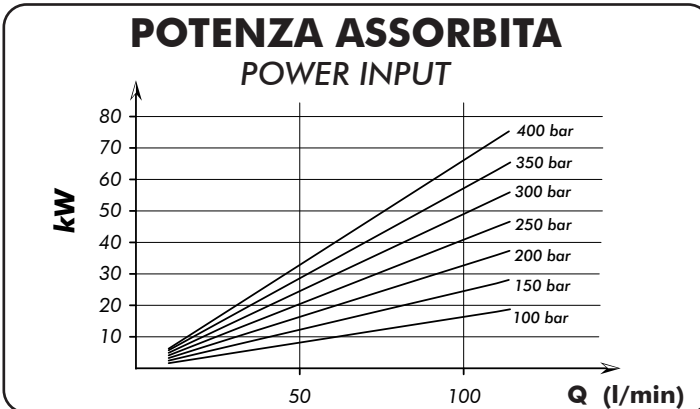
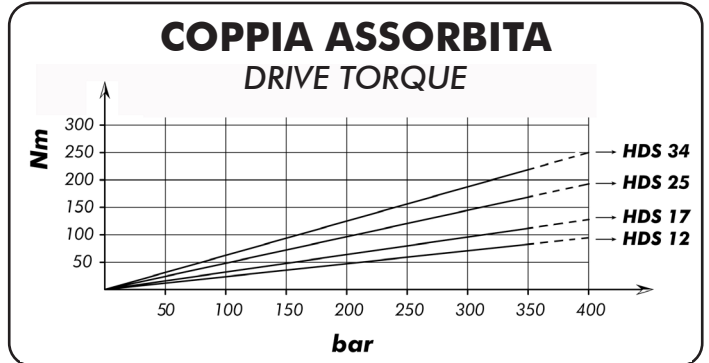
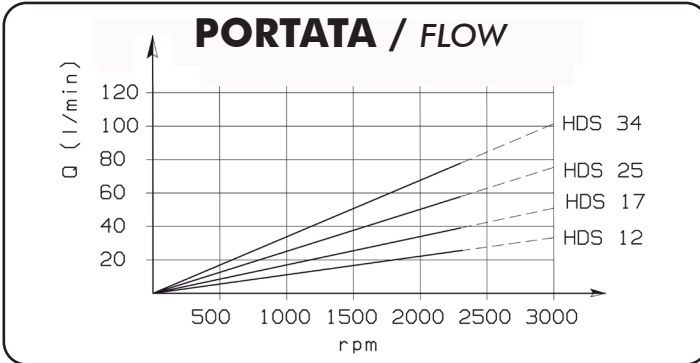

SCELTA DEL TUBO DI ASPIRAZIONE HOW TO CHOOSE THE SUCTION PIPE SIZE

Q Portata Flow l/min	Ø interno min. tubo Min pipe diam. mm	inch	Velocità flusso Flow speed (m/s)
20	25	1"	0,68
30	32	1" 1/4	0,62
40	32		0,83
50	38	1" 1/2	0,74
60	38		0,88
70	40	1" 9/16	0,93
80	45	1" 3/4	0,84
90	45		0,94
100	50	2"	0,85
110	50		0,93
120	60	2" 3/8	0,71
130	60		0,77
140	60		0,83
150	60		0,88
160	63	2" 1/2	0,86
170	63		0,91
180	63		0,96

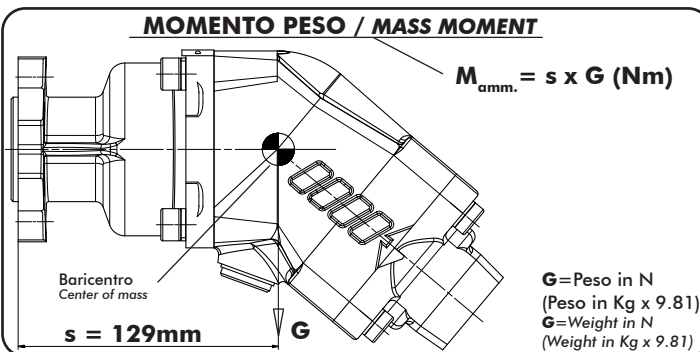
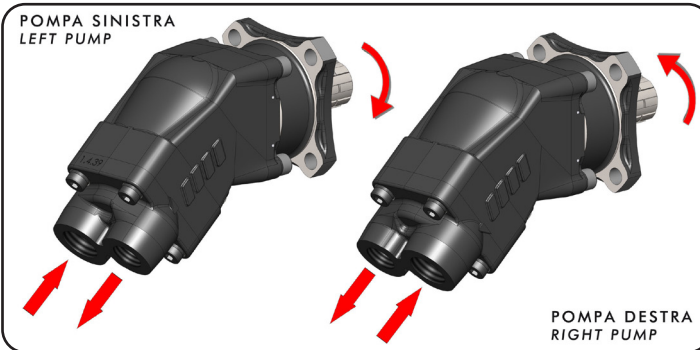

Per garantire corrette condizioni di aspirazione la velocità del flusso non deve superare 1 m/sec.
To ensure the proper suction pipe size the flow speed should not exceed 1mt/sec.

Kit guarnizioni / Seal Kit
GAS 10890326349

POMPE A PISTONI AD ASSE INCLINATO BENT AXIS PISTON PUMPS

CODICE FAMIGLIA
FAMILY CODE

613074

"HDS"

Flangia/Flange

SAE-B

"MDS"

Albero/Shaft

13T 16/32

Cilin./Displ.

40-47-55-64-80

99740060010



Fluido idraulico Fluid	Minerale o sintetico compatibile con guarnizioni: Mineral or synthetic compatible with the following seals: FKM, FPM, HNBR				
Viscosità cinematica consigliata Kinematic viscosity suggested	T media ambiente (°C) Average ambient temp. (°C)	< -40	-40 ÷ 10	10 ÷ 35	> 35
	VG (cSt = mm ² /s)	16	22	32	46
Viscosità cinematica ottimale di esercizio Optimale kinematic viscosity		VG = 10 cSt ÷ 100 cSt			
Viscosità cinematica max consentita all'avviamento Max kinematic viscosity suggested at the start-up		VG = 750 cSt			
Indice di viscosità consigliato Viscosity index suggested	VI > 100	Temperatura di esercizio Working temperature -15°C ÷ 140°C			
Grado di filtrazione Oil filtering		> 200 bar: 10 µm < 200 bar: 25 µm			
Pres. di aspirazione Inlet pressure		0,85 ÷ 2 bar assoluti/absolut			
Senso di rotazione Pump rotation		Unidirezionale (Dx o Sx) Unidirectional (Right or Left)			
Verificare che la pompa sia posizionata almeno 100 mm sotto il livello minimo del serbatoio olio. Prima di avviare la pompa effettuare spurgo aria. Verify that pump is, at least, 100 mm under the minimum level of the tank. Before starting the pump bleed the air.					

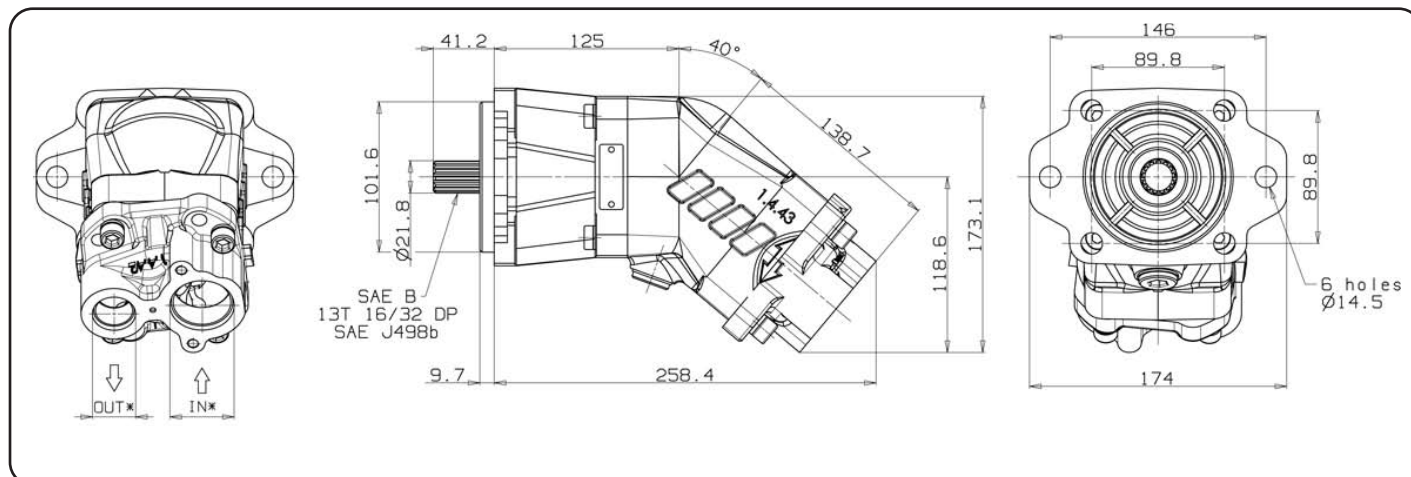

09/07/2020

99761301705 Rev. AB

Tipo pompa Pump type	Rotazione Rotation		IN	OUT
	Destra Right	Sinistra Left		
HDS SAE-B 40	61307450403	61307450409	1 5/8-12 UN-2B SAE 20	1 5/16-12 UN-2B SAE 16
HDS SAE-B 47	61307450473	61307450479		
HDS SAE-B 55	61307450553	61307450559		
HDS SAE-B 64	61307450643	61307450649		
MDS SAE-B 80	61307450803	61307450809		
			ISO 228	ISO 228
HDS SAE-B 40	61307410403	61307410409	G 1 1/4"	G 3/4"
HDS SAE-B 47	61307410473	61307410479		
HDS SAE-B 55	61307410553	61307410559		
HDS SAE-B 64	61307410643	61307410649		
MDS SAE-B 80	61307410803	61307410809		

pag. 69

O.M.F.B. S.p.A. Hydraulic Components

We reserve the right to make any changes without notice.

Edition 2016.06 No reproduction, however partial, is permitted.

Via Cave, 7/9 25050 Provaglio d'Iseo (Brescia) Italy Tel.: +39.030.9830611
Fax: +39.030.9839207-208 Internet: www.omfb.it e-mail: contatti@omfb.it

COMPANY WITH
QUALITY SYSTEM
CERTIFIED BY DNV GL
= IATF 16949 =



CARATTERISTICHE TECNICHE DI FUNZIONAMENTO
TECHNICAL FEATURES

Tipo pompa Pump type	Cilindrata Displacement cm ³ /rev	Pressione Pressure		Velocità / Speed			Velocità min. Min. speed rpm	Peso Weight kg
		P1 * bar	P3 * bar	V0 rpm	V1 rpm	V2 rpm		
HDS-40	41.25	350	375	2700	1900	2500	300	14.2
HDS-47	47.13	340	340					
HDS-55	56.70	280	280					
HDS-64	63.56	250	250					
MDS-80	77.25	210	210	2300	1800	2100		14.8

P1=Pressione massima continua Max. continuous pressure (100%)
P3=Pressione massima di punta Max. peak pressure (6 sec.max)

V0=Massima continua vuoto Max. continuous speed without load
V1=Massima continua Max. continuous speed
V2=Massima intermittente Max. intermittent speed



* I valori di pressione sono limitati a causa della coppia massima trasmissibile dall'albero SAE B (300 Nm).
Indicated pressure values are limited due to the max allowed torque on SAE B shaft (300 Nm).

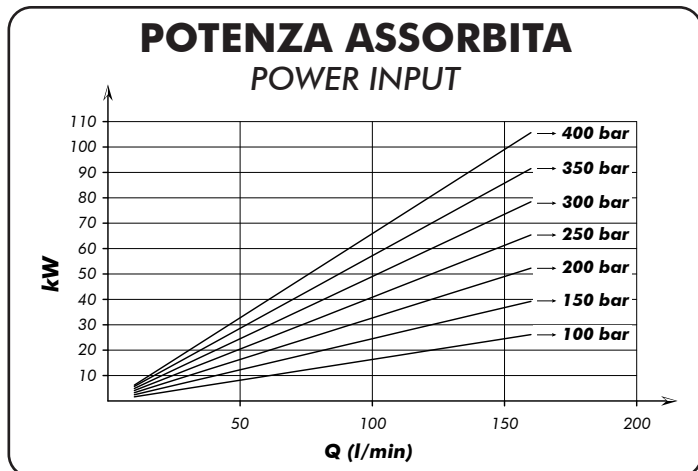
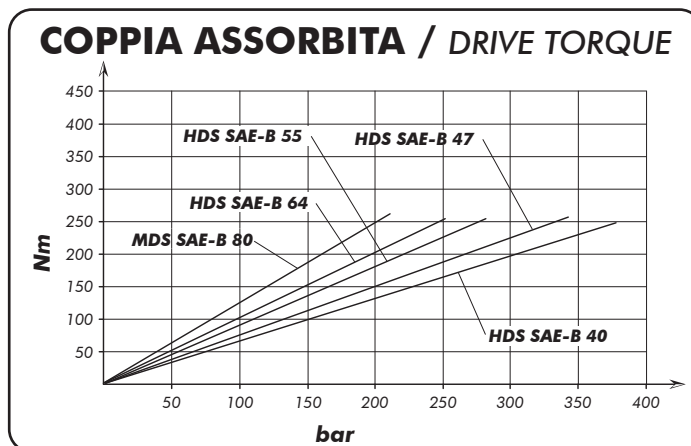
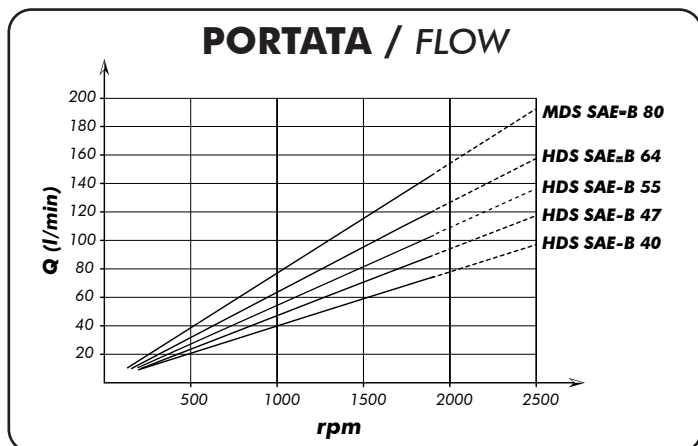

**SCELTA DEL TUBO DI ASPIRAZIONE
HOW TO CHOOSE THE SUCTION PIPE SIZE**

Q Portata Flow l/min	Ø interno min. tubo Min pipe diam.		Velocità flusso Flow speed (m/s)
	mm	inch	
20	25	1"	0,68
30	32	1" 1/4	0,62
40	32		0,83
50	38	1" 1/2	0,74
60	38		0,88
70	40	1" 9/16	0,93
80	45	1" 3/4	0,84
90	45		0,94
100	50	2"	0,85
110	50		0,93
120	60	2" 3/8	0,71
130	60		0,77
140	60		0,83
150	60		0,88
160	63	2" 1/2	0,86
170	63		0,91
180	63		0,96

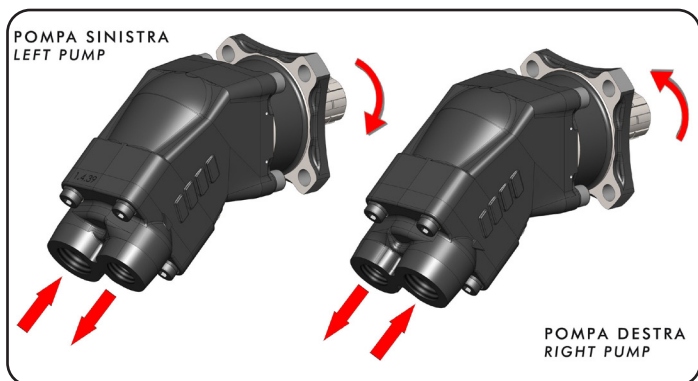

Per garantire corrette condizioni di aspirazione la velocità del flusso non deve superare 1 m/sec.
To ensure the proper suction pipe size the flow speed should not exceed 1m/sec.

Kit guarnizioni / Seal Kit
10890300214

POMPE A PISTONI AD ASSE INCLINATO BENT AXIS PISTON PUMPS

CODICE FAMIGLIA
FAMILY CODE

613077

"HDS"
"MDS"

Flangia/Flange
Albero/Shaft
Cilin./Displ.

SAE-BB
15T 16/32
47-55-64-80

99740060010



Fluido idraulico Fluid	Minerale o sintetico compatibile con guarnizioni: Mineral or synthetic compatible with the following seals: FKM, FPM, HNBR				
Viscosità cinematica consigliata Kinematic viscosity suggested	T media ambiente (°C) Average ambient temp. (°C)	< -40	-40 ÷ 10	10 ÷ 35	> 35
	VG (cSt = mm ² /s)	16	22	32	46
Viscosità cinematica ottimale di esercizio Optimale kinematic viscosity		VG = 10 cSt ÷ 100 cSt			
Viscosità cinematica max consentita all'avviamento Max kinematic viscosity suggested at the start-up		VG = 750 cSt			
Indice di viscosità consigliato Viscosity index suggested	VI > 100	Temperatura di esercizio Working temperature -15°C ÷ 140°C			
Grado di filtrazione Oil filtering		> 200 bar: 10 µm < 200 bar: 25 µm			
Pres. di aspirazione Inlet pressure		0,85 ÷ 2 bar assoluti/absolut			
Senso di rotazione Pump rotation		Unidirezionale (Dx o Sx) Unidirectional (Right or Left)			
Verificare che la pompa sia posizionata almeno 100 mm sotto il livello minimo del serbatoio olio. Prima di avviare la pompa effettuare spurgo aria. Verify that pump is, at least, 100 mm under the minimum level of the tank. Before starting the pump bleed the air.					

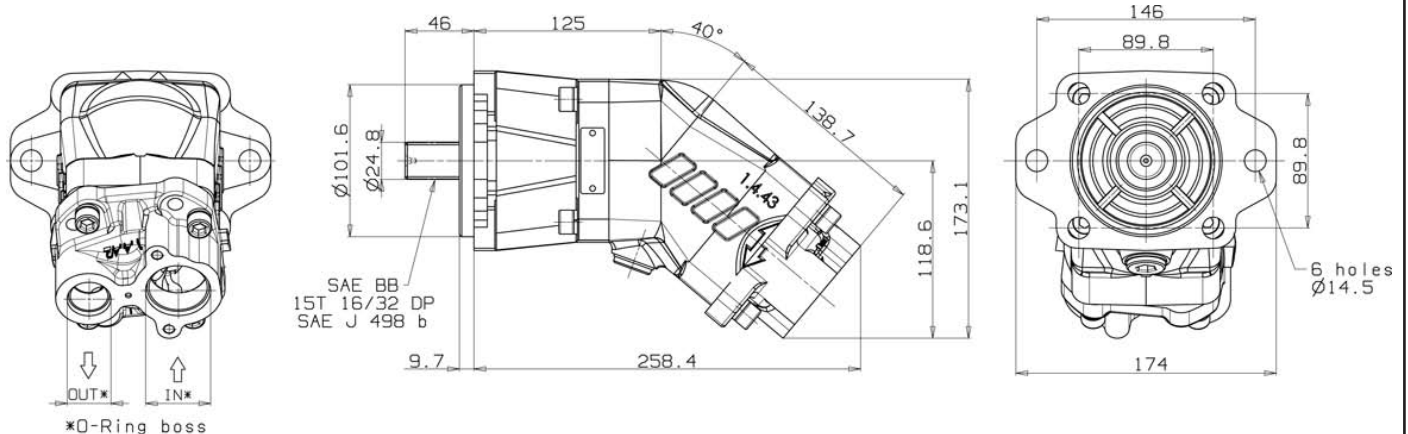

07/03/2017

99761301805 Rev. AA

Tipo pompa Pump type	Rotazione Rotation		IN	OUT
	Destra Right	Sinistra Left		
HDS SAE-BB 47	61307750473	61307750479	ISO 725	ISO 725
HDS SAE-BB 55	61307750553	61307750559	1 5/8-12 UN-2B SAE 20	1 1/16-12 UN-2B SAE 12
HDS SAE-BB 64	61307750643	61307750649		
MDS SAE-BB 80	61307750803	61307750809		
HDS SAE-BB 47	61307710473	61307710479	ISO 228	ISO 228
HDS SAE-BB 55	61307710553	61307710559	G 1 1/4"	G 3/4"
HDS SAE-BB 64	61307710643	61307710649		
MDS SAE-BB 80	61307710803	61307710809		

pag.71



O.M.F.B. S.p.A. Hydraulic Components
We reserve the right to make any changes without notice.
Edition 2016.06 No reproduction, however partial, is permitted.
Via Cave, 7/9 25050 Provaglio d'Iseo (Brescia) Italy Tel.: +39.030.9830611
Fax: +39.030.9839207-208 Internet:www.omfb.it e-mail:contatti@omfb.it

COMPANY WITH
QUALITY SYSTEM
CERTIFIED BY DNV GL
= IATF 16949 =

CARATTERISTICHE TECNICHE DI FUNZIONAMENTO
TECHNICAL FEATURES

Tipo pompa Pump type	Cilindrata Displacement cm ³ /rev	Pressione Pressure		Velocità / Speed			Velocità min. Min. speed rpm	Peso Weight kg
		P1 * bar	P3 * bar	V0 rpm	V1 rpm	V2 rpm		
HDS-47	47.13	350	400	2700	1900	2500	300	13.9
HDS-55	56.70		400					14
HDS-64	63.56		380					13.8
MDS-80	77.25	310	310	2300	1800	2100		13.6

P1=Pressione massima continua Max. continuous pressure (100%)
P3=Pressione massima di punta Max. peak pressure (6 sec.max)

V0=Massima continua vuoto Max. continuous speed without load
V1=Massima continua Max. continuous speed
V2=Massima intermittente Max. intermittent speed

! * I valori di pressione sono limitati a causa della coppia massima trasmissibile dall'albero SAE BB (450 Nm)
Indicated pressure values are limited due to the max allowed torque on SAE BB shaft (450 Nm).

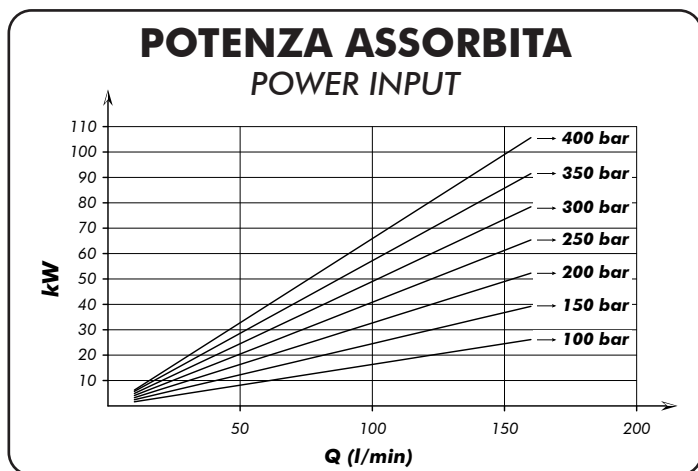
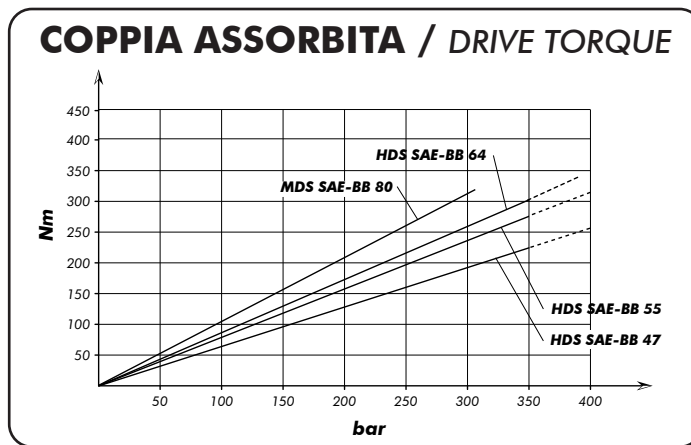
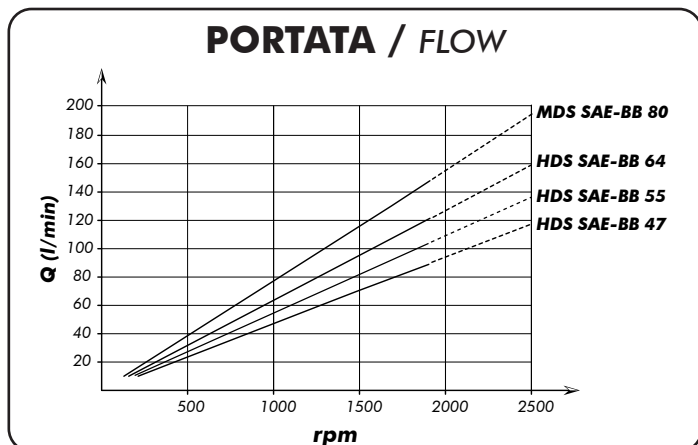

**SCELTA DEL TUBO DI ASPIRAZIONE
HOW TO CHOOSE THE SUCTION PIPE SIZE**

Q Portata Flow l/min	Ø interno min. tubo Min pipe diam. mm inch		Velocità flusso Flow speed (m/s)
20	25	1"	0,68
30	32	1" 1/4	0,62
40	32		0,83
50	38	1" 1/2	0,74
60	38	1" 9/16	0,88
70	40		0,93
80	45	1" 3/4	0,84
90	45	1" 3/4	0,94
100	50		0,85
110	50	2"	0,93
120	60	2" 3/8	0,71
130	60		0,77
140	60		0,83
150	60		0,88
160	63	2" 1/2	0,86
170	63		0,91
180	63		0,96

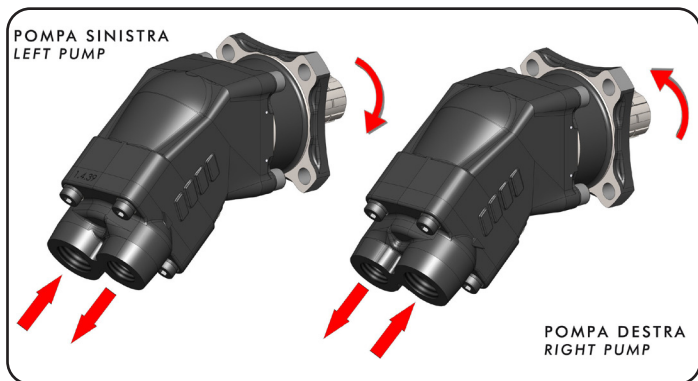

Per garantire corrette condizioni di aspirazione la velocità del flusso non deve superare 1 m/sec.
To ensure the proper suction pipe size the flow speed should not exceed 1m/sec.

Kit guarnizioni / Seal Kit
10890300214

POMPE A PISTONI AD ASSE INCLINATO BENT AXIS PISTON PUMPS

CODICE FAMIGLIA
FAMILY CODE

614080

"HDS"

Flangia/Flange

SAE-C

"MDS"

Albero/Shaft

14T 12/24

Cilin./Displ.

47-55-64-80

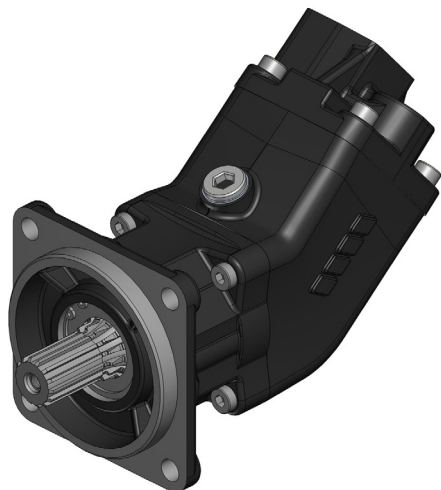

99740060010

Fluido idraulico Fluid	Minerale o sintetico compatibile con guarnizioni: Mineral or synthetic compatible with the following seals: FKM, FPM, HNBR				
Viscosità cinematica consigliata Kinematic viscosity suggested	T media ambiente (°C) Average ambient temp. (°C)	< -40	-40 ÷ 10	10 ÷ 35	> 35
	VG (cSt = mm ² /s)	16	22	32	46
Viscosità cinematica ottimale di esercizio Optimale kinematic viscosity		VG = 10 cSt ÷ 100 cSt			
Viscosità cinematica max consentita all'avviamento Max kinematic viscosity suggested at the start-up		VG = 750 cSt			
Indice di viscosità consigliato Viscosity index suggested	VI > 100	Temperatura di esercizio Working temperature -15°C ÷ 140°C			
Grado di filtrazione Oil filtering		> 200 bar: 10 µm < 200 bar: 25 µm			
Pres. di aspirazione Inlet pressure		0,85 ÷ 2 bar assoluti/absolut			
Senso di rotazione Pump rotation		Unidirezionale (Dx o Sx) Unidirectional (Right or Left)			
Verificare che la pompa sia posizionata almeno 100 mm sotto il livello minimo del serbatoio olio. Prima di avviare la pompa effettuare spurgo aria. Verify that pump is, at least, 100 mm under the minimum level of the tank. Before starting the pump bleed the air.					

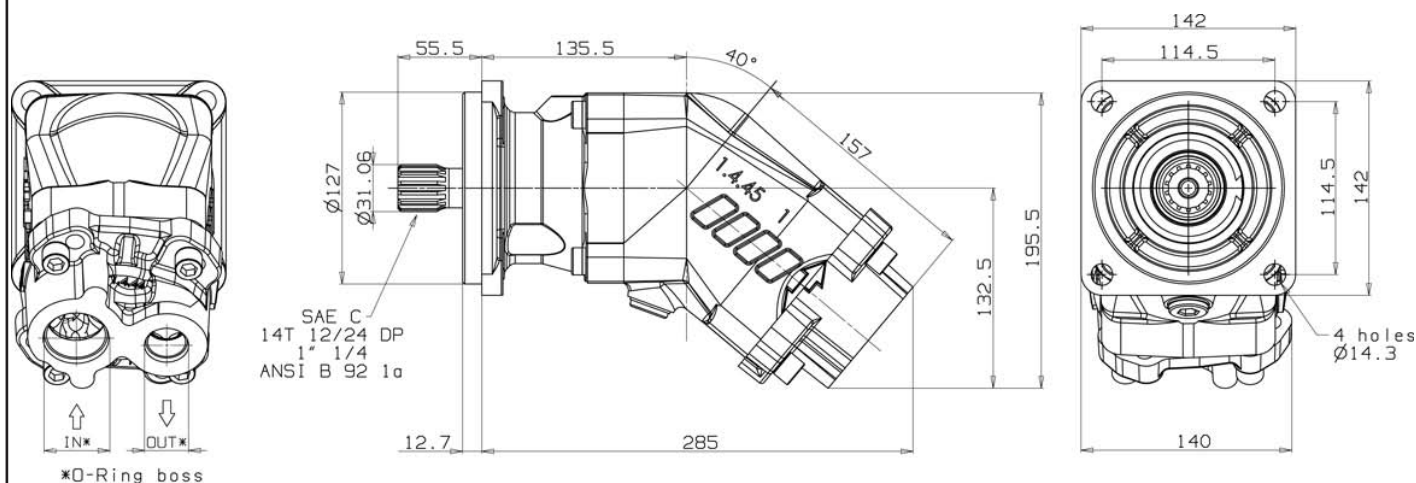

07/03/2017

99761402005 Rev. AA

Tipo pompa Pump type	Rotazione Rotation		IN	OUT
	Destra Right	Sinistra Left		
HDS SAE-C 47	61408050473	61408050479	ISO 725	ISO 725
HDS SAE-C 55	61408050553	61408050559	1 5/8-12 UN-2B SAE 20	1 1/16-12 UN-2B SAE 12
HDS SAE-C 64	61408050643	61408050649		
MDS SAE-C 80	61408050803	61408050809		
HDS SAE-C 47	61408010473	61408010479	ISO 228	ISO 228
HDS SAE-C 55	61408010553	61408010559	G 1 1/4"	G 3/4"
HDS SAE-C 64	61408010643	61408010649		
MDS SAE-C 80	61408010803	61408010809		

pag.73

O.M.F.B. S.p.A. Hydraulic Components

We reserve the right to make any changes without notice.

Edition 2016.06 No reproduction, however partial, is permitted.

Via Cave, 7/9 25050 Provaglio d'Iseo (Brescia) Italy Tel.: +39.030.9830611
Fax: +39.030.9839207-208 Internet:www.omfb.it e-mail:contatti@omfb.it

**COMPANY WITH
QUALITY SYSTEM
CERTIFIED BY DNV GL
= IATF 16949 =**



CARATTERISTICHE TECNICHE DI FUNZIONAMENTO
TECHNICAL FEATURES

Tipo pompa Pump type	Cilindrata Displacement cm ³ /rev	Pressione Pressure		Velocità / Speed			Velocità min. Min. speed rpm	Peso Weight kg
		P1 bar	P3 bar	V0 rpm	V1 rpm	V2 rpm		
HDS-47	47.13	350	400	2700	1900	2500	300	14.3
HDS-55	56.70							
HDS-64	63.56	250	300	2300	1800	2100	300	14.2
MDS-80	77.25							

P1=Pressione massima continua Max. continuous pressure (100%)
P3=Pressione massima di punta Max. peak pressure (6 sec.max)

V0=Massima continua vuoto Max. continuous speed without load
V1=Massima continua Max. continuous speed
V2=Massima intermittente Max. intermittent speed

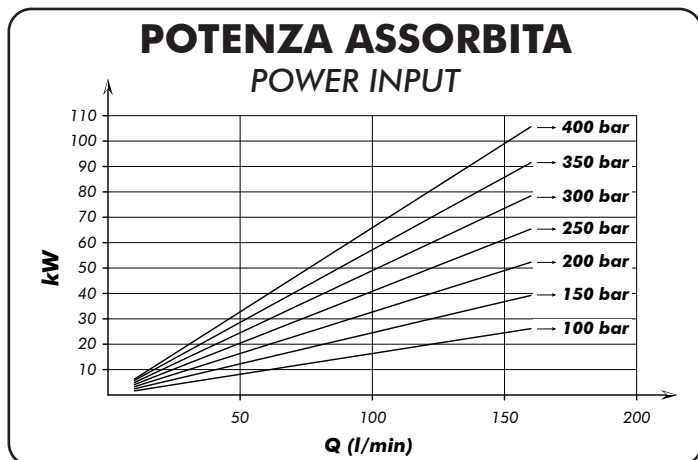
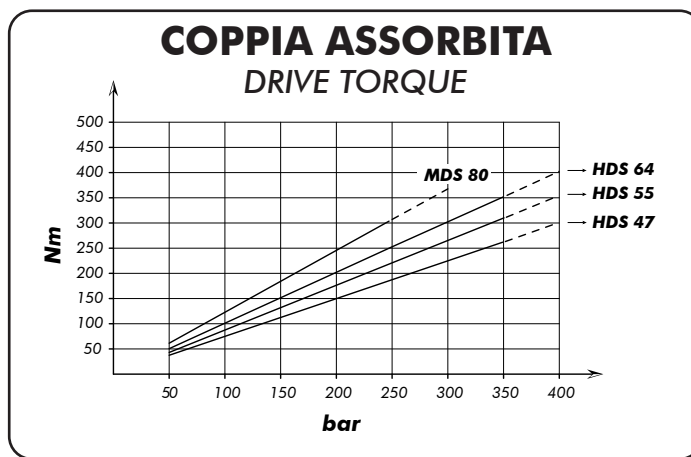
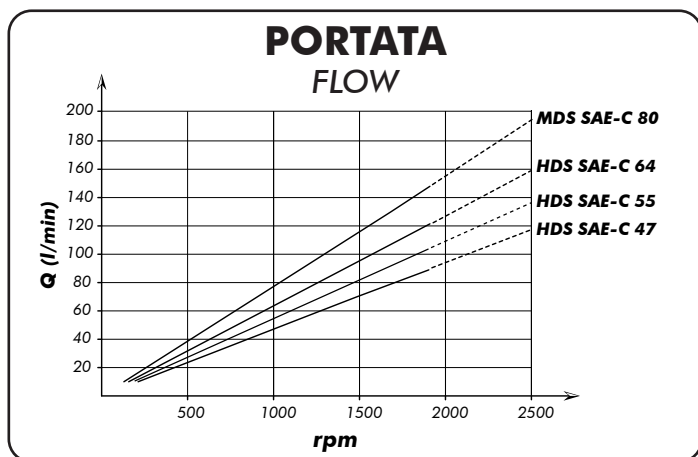

SCELTA DEL TUBO DI ASPIRAZIONE HOW TO CHOOSE THE SUCTION PIPE SIZE

Q Portata Flow l/min	□ interno min. tubo Min pipe diam. mm	inch	Velocità flusso Flow speed (m/s)
20	25	1"	0,68
30	32	1" 1/4	0,62
40	32		0,83
50	38	1" 1/2	0,74
60	38	1" 3/4	0,88
70	40		0,93
80	45	2"	0,84
90	45		0,94
100	50	2"	0,85
110	50		0,93
120	60	2" 3/8	0,71
130	60		0,77
140	60		0,83
150	60		0,88
160	63	2" 1/2	0,86
170	63		0,91
180	63		0,96

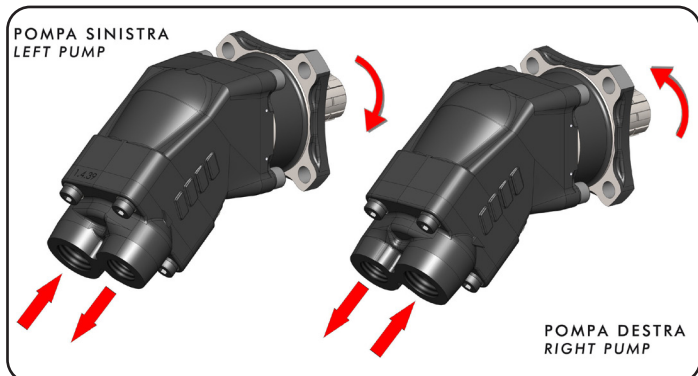

Kit guarnizioni / Seal Kit
10890300223

POMPE A PISTONI AD ASSE INCLINATO BENT AXIS PISTON PUMPS

CODICE FAMIGLIA
FAMILY CODE

614080

"HDS"
"MDS"

Flangia/Flange
Albero/Shaft
Cilin./Displ.

SAE-C
14T 12/24
84-108-130



99740060010

Fluido idraulico Fluid	Minerale o sintetico compatibile con guarnizioni: Mineral or synthetic compatible with the following seals: FKM, FPM, HNBR				
Viscosità cinematica consigliata Kinematic viscosity suggested	T media ambiente (°C) Average ambient temp. (°C)	< -40	-40 ÷ 10	10 ÷ 35	> 35
	VG (cSt = mm ² /s)	16	22	32	46
Viscosità cinematica ottimale di esercizio Optimale kinematic viscosity		VG = 10 cSt ÷ 100 cSt			
Viscosità cinematica max consentita all'avviamento Max kinematic viscosity suggested at the start-up		VG = 750 cSt			
Indice di viscosità consigliato Viscosity index suggested	VI > 100	Temperatura di esercizio Working temperature -15°C ÷ 140°C			
Grado di filtrazione Oil filtering		> 200 bar: 10 µm < 200 bar: 25 µm			
Pres. di aspirazione Inlet pressure		0,85 ÷ 2 bar assoluti/absolut			
Senso di rotazione Pump rotation		Unidirezionale (Dx o Sx) Unidirectional (Right or Left)			
Verificare che la pompa sia posizionata almeno 100 mm sotto il livello minimo del serbatoio olio. Prima di avviare la pompa effettuare spurgo aria. Verify that pump is, at least, 100 mm under the minimum level of the tank. Before starting the pump bleed the air.					

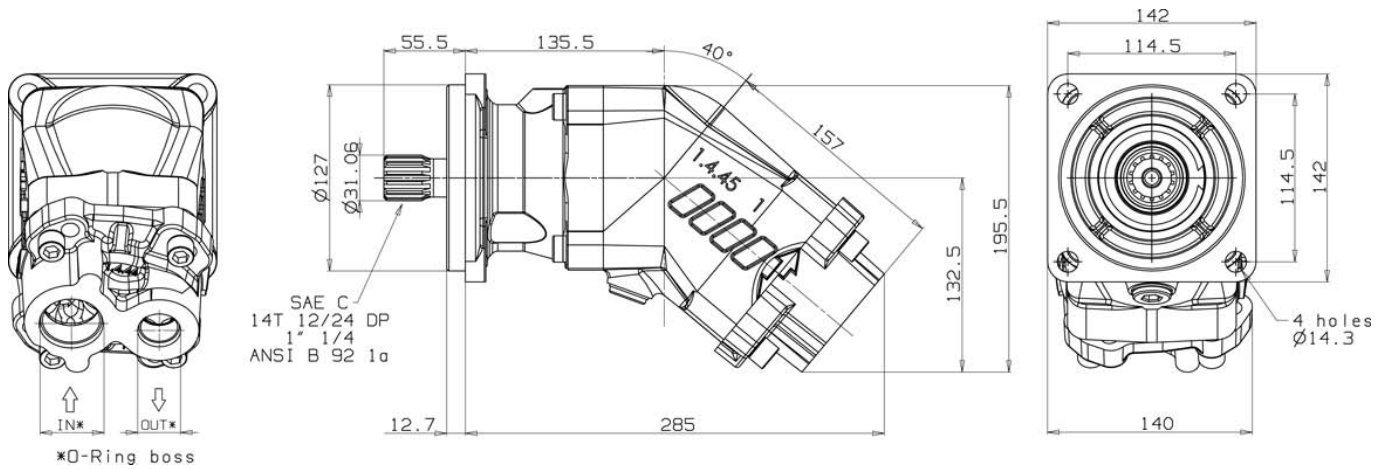

31/10/2017

Tipo pompa Pump type	Rotazione Rotation		IN	OUT
	Destra Right	Sinistra Left		
HDS SAE-C 84	61408050843	61408050849	1 7/8-12 UN-2B SAE 24	1 5/16-12 UN-2B SAE 16
HDS SAE-C 108	61408051083	61408051089		
MDS SAE-C 130	61408051303	61408051309		
			ISO 228	ISO 228
HDS SAE-C 84	61408010843	61408010849	G 1 1/4"	G 1"
HDS SAE-C 108	61408011083	61408011089		
MDS SAE-C 130	61408011303	61408011309		

99761402020 Rev. AB

pag.75



O.M.F.B. S.p.A. Hydraulic Components
We reserve the right to make any changes without notice.
Edition 2016.06 No reproduction, however partial, is permitted.
Via Cave, 7/9 25050 Provaglio d'Iseo (Brescia) Italy Tel.: +39.030.9830611
Fax: +39.030.9839207-208 Internet:www.omfb.it e-mail:contatti@omfb.it

COMPANY WITH
QUALITY SYSTEM
CERTIFIED BY DNV GL
= IATF 16949 =

CARATTERISTICHE TECNICHE DI FUNZIONAMENTO
TECHNICAL FEATURES

Tipo pompa Pump type	Cilindrata Displacement cm ³ /rev	Pressione Pressure		Velocità / Speed			Velocità min. Min. speed rpm	Peso Weight kg
		P1 bar	P3 bar	V0 rpm	V1 rpm	V2 rpm		
HDS-84	84.33	350	400	2300	1500	2000	300	21.5
HDS-108	107							21
MDS-130	131.62	250	270					21

P1=Pressione massima continua Max. continuous pressure (100%)
P3=Pressione massima di punta Max. peak pressure (6 sec.max)

V0=Massima continua vuoto Max. continuous speed without load
V1=Massima continua Max. continuous speed
V2=Massima intermittente Max. intermittent speed

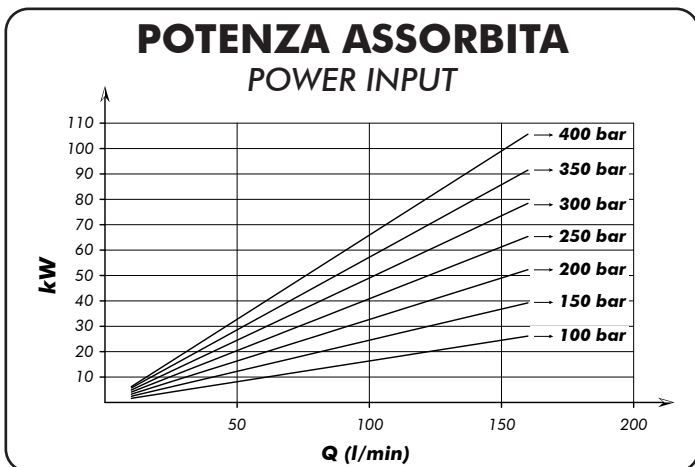
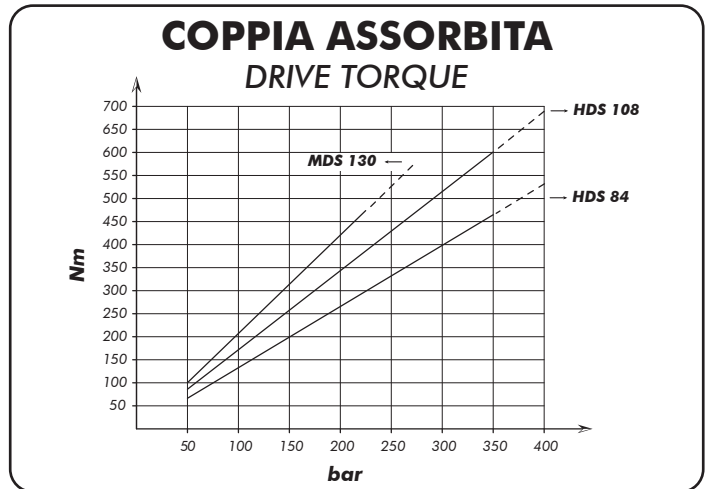
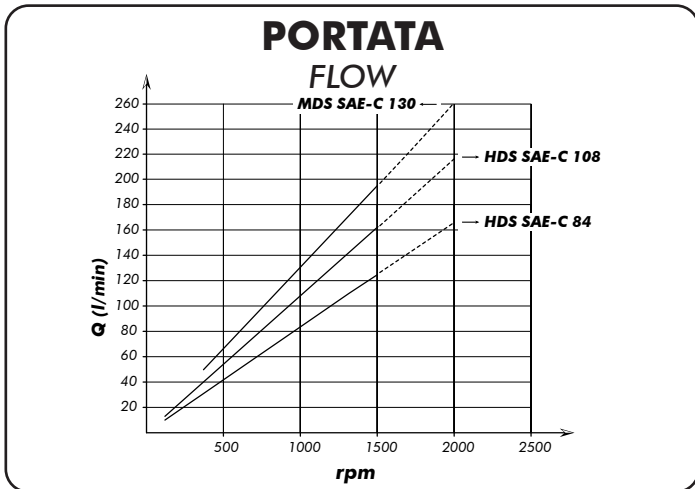

SCELTA DEL TUBO DI ASPIRAZIONE
HOW TO CHOOSE THE SUCTION PIPE SIZE

Q Portata Flow l/min	Ø interno min. tubo Min pipe diam.		Velocità flusso Flow speed (m/s)
	mm	inch	
20	25	1"	0,68
30	32	1" 1/4	0,62
40	32	1" 1/4	0,83
50	38	1" 1/2	0,74
60	38	1" 1/2	0,88
70	40	1" 9/16	0,93
80	45	1" 3/4	0,84
90	45	1" 3/4	0,94
100	50	2"	0,85
110	50	2"	0,93
120	60	2" 3/8	0,71
130	60		0,77
140	60		0,83
150	60	2" 1/2	0,88
160	63		0,86
170	63		0,91
180	63	2" 1/2	0,96

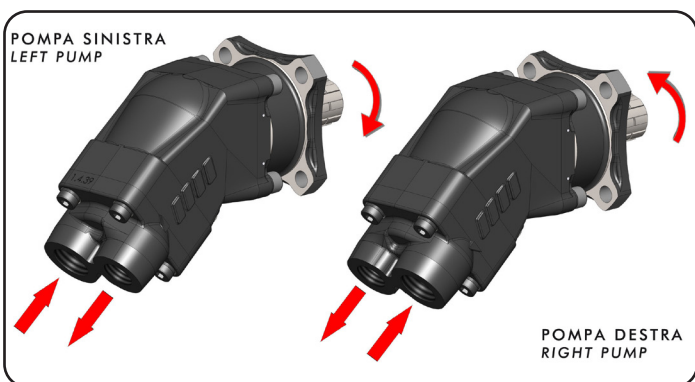

Per garantire corrette condizioni di aspirazione la velocità del flusso non deve superare 1 m/sec.
To ensure the proper suction pipe size the flow speed should not exceed 1mt/sec.

Kit guarnizioni / Seal Kit
10890300232

99740060010

07/03/2017

99761402005 Rev. AA

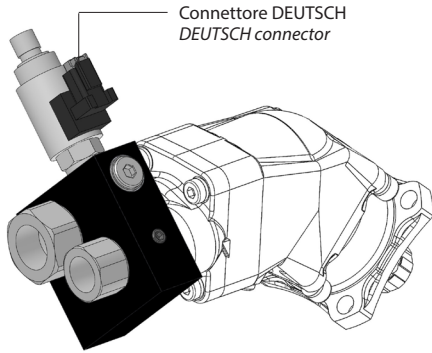

La valvola di by-pass viene utilizzata unitamente alle pompe a pistoni Bent axis HDS nel caso in cui la pompa sia sempre in rotazione quando il veicolo è acceso (montaggio con prese di forza senza innesto o direttamente sul motore). In questi casi tutto il flusso di olio erogato viene mandato in circolo alla massima portata della pompa, concessa dal numero di giri del motore, attraverso tubazioni che solitamente non sono dimensionate per portate superiori a quelle richieste durante il normale utilizzo della pompa, causando perciò perdite di energia inutili nonché surriscaldamenti dell'impianto. La valvola di by-pass svolge la funzione di ricircolare parzialmente il flusso di olio Q della pompa all'interno della pompa stessa in modo che, attraverso le tubazioni dell'impianto, circoli una portata Q1 pari alla differenza fra la portata Q e la portata di riciclo Q2. La ripartizione della portata nei flussi Q1 e Q2 dipende dalle perdite di carico dell'impianto e della valvola di by-pass. È comunque necessario garantire una portata di olio Q1 di almeno 5-10 l/min per assicurare un sufficiente raffreddamento della pompa.

The bypass valve is used together with HDS bent axis piston pumps if the pump turns constantly when the vehicle is on (in installations with the power takeoff without a coupling or coupled directly to the motor). In such cases, all the oil flow delivered is circulated, at the maximum pump capacity permitted by the turning speed of the motor, through piping that is usually not sized for capacities greater than those required for the normal use of the pump, consequently giving rise to pointless energy losses and overheating in the system. The bypass valve serves the purpose of partially recirculating the pump's oil flow Q (see diagram 1) inside the pump so that a flow Q1 (corresponding to the difference between the total flow Q and the recycled flow Q2) circulates through the system's piping. The proportion of total capacity distributed to the flows Q1 and Q2 depends on the system load losses and the bypass valve. In any case, it is essential to guarantee an oil flow Q1 of at least 5-10 l/min to ensure adequate pump cooling.

Ingombro / Dimensions

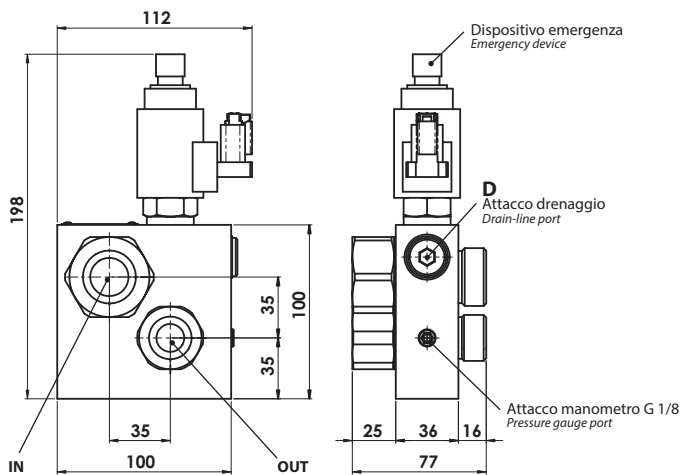

Schema idraulico / Hydraulic layout

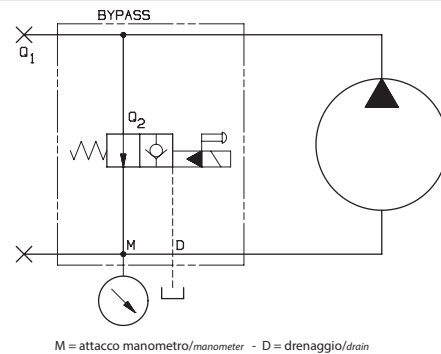

Caratteristiche bobina / Coil features

Assorbimento a 20°C: 20,5W	Power at 20°C: 24W
Duty cycle: ED 100%	
Grado di protezione: IP67	Protection class: IP67
Classe di isolamento bobina: F	Coil insulation class: F
Classe di isolamento cavi: H (185°C)	Wire insulation: H (185°C)
Trattamento: Zinco-Nichel	Treatment: Zinc-Nikel

Posizioni di montaggio / Mounting positions

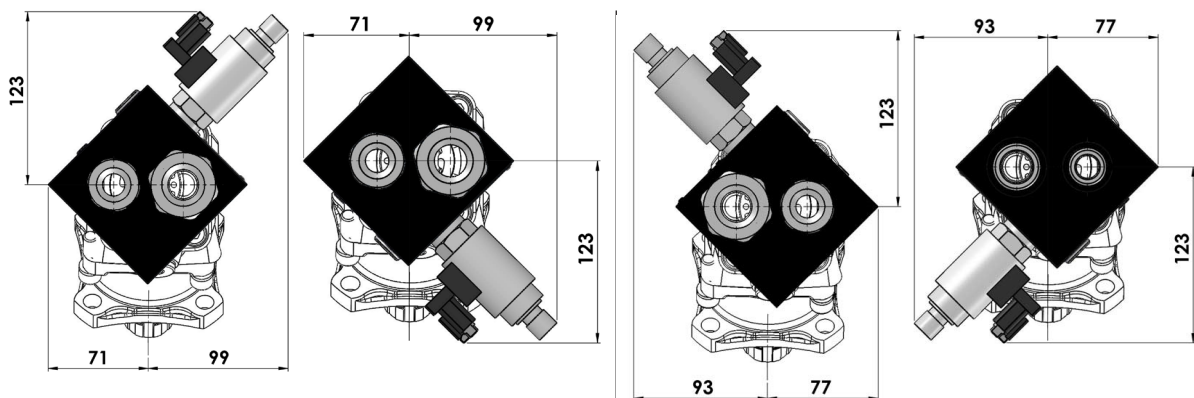

Dati tecnici / Technical features

Tipo pompa Pump type	Codice ordinazione Order code		Pressione max. Max. pressure	IN	OUT	D	Peso Weight
	12V	24V					
HDS-12/17/25/34	10820012345	10820024341	400	G1	G3/4	G3/8	3,2

* Vedere catalogo pompe per le pressioni delle singole pompe / See pumps catalogue for related pressure values.

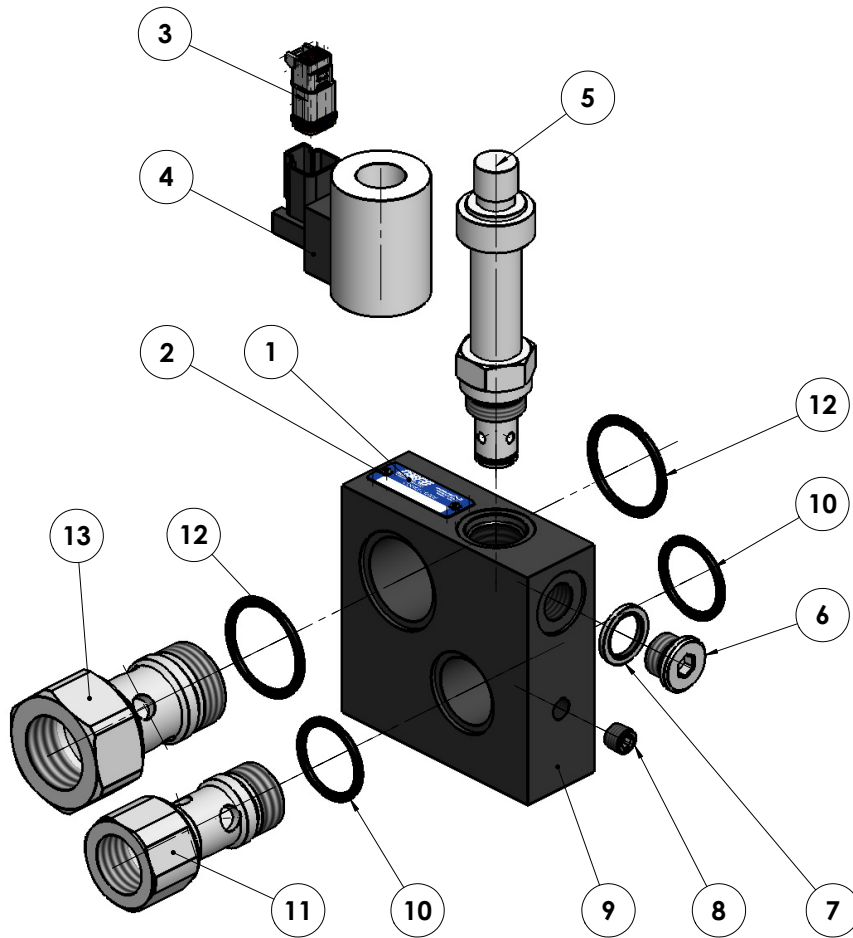

N°	Codice Code	Descrizione Description		Q.
1	5130000011	Chiodino fissaggio targhetta	Plate nail	2
2	513.....	Targhetta completa	Plate	1
3	13104500045	Connettore 2 poli DEUTSCH	2-Pole connector DEUTSCH	1
4	14917532123	Bobina DEUTSCH 12V	Coil DEUTSCH 12V	1
	14917532249	Bobina DEUTSCH 24V	Coil DEUTSCH 24V	1
5	14990600224	Cartuccia 7/8-14	Cartridge 7/8-14	1
6	11500600126	Tappo cieco acciaio TCE 3/8"	Blank plug TCE 3/8"	1
7	11600910085	Rondella acciaio gomma	Copper washer	1
8	50401000063	Grano conico 1/8"	Grub screw 1/8"	1
9	52000000614	Corpo valvola bypass	Bypass body	1
10	50600603112	Guarnizione OR	O-Ring	2
11	54000500359	Tappo passante 3/4"	Go-through cap 3/4"	1
12	50600603143	Guarnizione OR	O-Ring	2
13	54000500537	Tappo passante 1" - 2 ^a serie	Go-through cap 1" - 2 nd series	1

Tipo pompa Pump type	Kit ricambio guarnizioni Gaskets kit spare part
HDS-12/17/25/34	10890300072

Istruzioni di montaggio / Mounting instructions

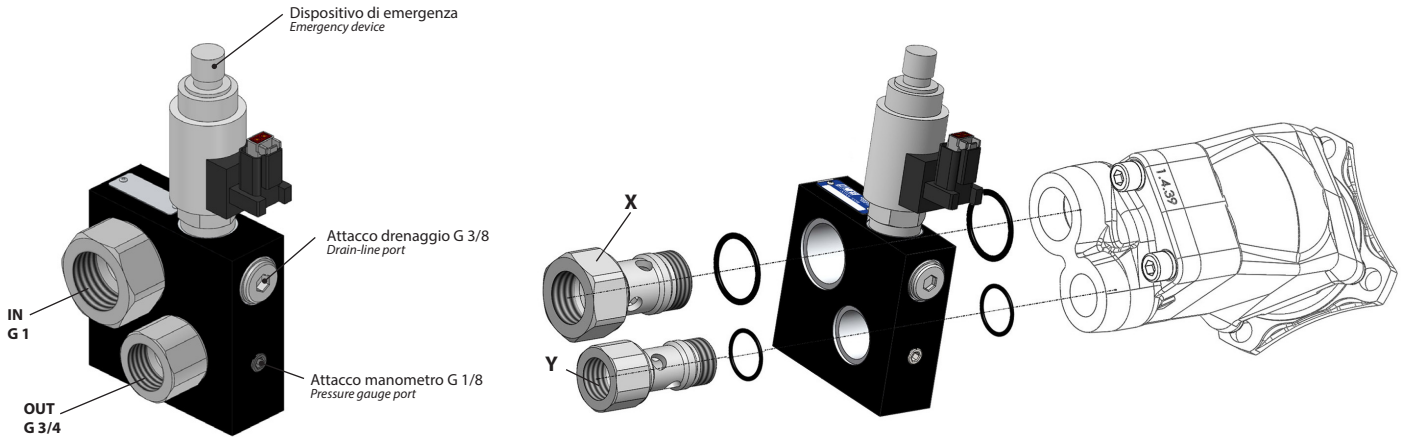

- 1 - Pulire molto bene le superfici della pompa e della valvola che andranno a contatto.
- 2 - Interporre le guarnizioni (o-ring) fornite a corredo, usando grasso, come indicato in figura.
- 3 - Avvitare il particolare **X** ed il particolare **Y** (per coppie di serraggio vedi tabella).
- 4 - Collegare tubi aspiraz./mandata.
- 5 - Collegamento elettrico: la valvola di by-pass è normalmente aperta.
Per utilizzare la pompa in pressione eccitare l'elettrovalvola.

- 1 - Clean the pump and by-pass valve surfaces.
- 2 - Place the o-ring included in the kit as shown in the picture, with grease.
- 3 - Screw in **X** part and **Y** part (see tightening torque in the table).
- 4 - Connect pressure/suction pipe.
- 5 - Electrical wiring-up: the by-pass valve is normally open. To deliver oil you have to energise the solenoid valve.

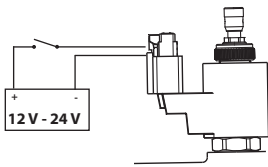

COPPIE DI SERRAGGIO TIGHTENING TORQUE	
G 1/2	80 Nm
G 3/4	140 Nm
G 1	170 Nm
G 1 1/4	200 Nm
G 1 1/2	250 Nm

ATTENZIONE / WARNING

L'elettrovalvola viene azionata da un interruttore elettrico posto in cabina. La valvola di by-pass viene normalmente impiegata in impianti che prevedono il distributore principale a centro aperto.



Nel caso in cui venga impiegata in impianti con distributore a centro chiuso o nel caso in cui non siano garantiti i 5-10 l/min di portata (Q1) attraverso le tubazioni, è necessario collegare un tubo fra il foro di drenaggio della valvola e il serbatoio.

L'elettrovalvola è dotata di un dispositivo di emergenza in modo che si possa utilizzare la pompa anche in caso di avaria dell'elettrovalvola stessa. Azionamento emergenza di tipo "spingi e gira". La valvola può essere utilizzata indifferentemente per pompe con rotazione destra o sinistra e può essere montata in due diverse posizioni ruotate di 180° in modo da ottimizzarne gli ingombri. Al raccordo da G 1/8 è possibile collegare un manometro per la misura della pressione..

The solenoid valve is operated by an electric switch situated in the cab. The bypass valve is normally used in systems with an open-center main distributor.



If it is used in systems with a closed-center distributor, or if it is impossible to guarantee the minimum flow rate of 5-10 l/min (Q1) through the piping, it becomes necessary to connect a pipe drain valve hole and the tank.

This emergency is "push and twist" type. The solenoid valve is complete with an emergency device so that the pump can be used even in the event of a solenoid valve malfunction. The valve can be used equally for pumps turning either to the right or to the left and it can be installed in two different positions, rotated through 180° so as to make best use of available space. A pressure gauge can be connected to the G 1/8 connection to enable pressure measurements.

OPTIONAL

Kit elettrico / Electric kit
Codice / Code **30600102357**



OPTIONAL

Connettore 2 Poli "DEUTSCH" femmina
2-Pole female connector DEUTSCH
Codice / Code **13104500045**

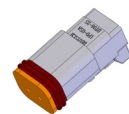

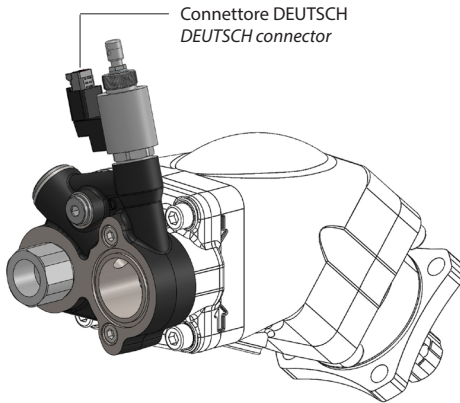

La valvola di by-pass viene utilizzata unitamente alle pompe a pistoni Bent axis HDS-HDT nel caso in cui la pompa sia sempre in rotazione quando il veicolo è acceso (montaggio con prese di forza senza innesto o direttamente sul motore). In questi casi tutto il flusso di olio erogato viene mandato in circolo alla massima portata della pompa, concessa dal numero di giri del motore, attraverso tubazioni che solitamente non sono dimensionate per portate superiori a quelle richieste durante il normale utilizzo della pompa, causando perciò perdite di energia inutili nonché surriscaldamenti dell'impianto. La valvola di by-pass svolge la funzione di ricircolare parzialmente il flusso di olio Q della pompa all'interno della pompa stessa in modo che, attraverso le tubazioni dell'impianto, circoli una portata Q1 pari alla differenza fra la portata Q e la portata di riciclo Q2. La ripartizione della portata nei flussi Q1 e Q2 dipende dalle perdite di carico dell'impianto e della valvola di by-pass. È comunque necessario garantire una portata di olio Q1 di almeno 5-10 l/min per assicurare un sufficiente raffreddamento della pompa.

The bypass valve is used together with HDS-HDT bent axis piston pumps if the pump turns constantly when the vehicle is on (in installations with the power takeoff without a coupling or coupled directly to the motor). In such cases, all the oil flow delivered is circulated, at the maximum pump capacity permitted by the turning speed of the motor, through piping that is usually not sized for capacities greater than those required for the normal use of the pump, consequently giving rise to pointless energy losses and overheating in the system. The bypass valve serves the purpose of partially recirculating the pump's oil flow Q (see diagram 1) inside the pump so that a flow Q1 (corresponding to the difference between the total flow Q and the recycled flow Q2) circulates through the system's piping. The proportion of total capacity distributed to the flows Q1 and Q2 depends on the system load losses and the bypass valve. In any case, it is essential to guarantee an oil flow Q1 of at least 5-10 l/min to ensure adequate pump cooling.

Ingombro / Dimensions

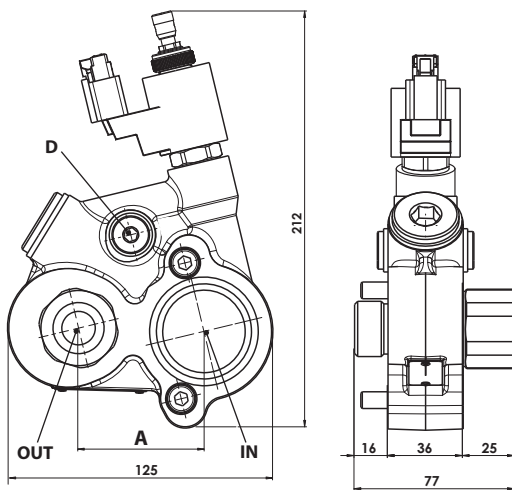

Schema idraulico / Hydraulic layout

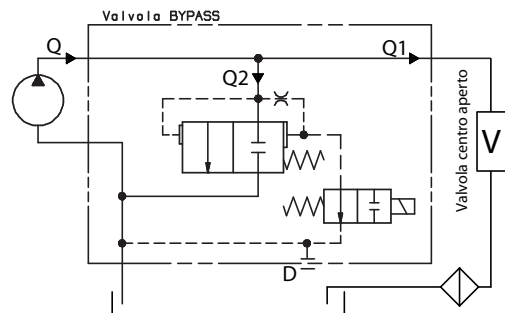

Caratteristiche bobina / Coil features

Assorbimento a 20°C: 20,5W	Power at 20°C: 20,5W
Duty cycle: ED 100%	
Grado di protezione: IP67	Protection class: IP67
Classe di isolamento bobina: H (180°C)	Coil insulation class: H (180°C)
Classe di isolamento cavi rame: H (185°C)	Copper wire insulation: H (185°C)
Trattamento: Zinco-Nichel	Treatment: Zinc-Nikel

Posizioni di montaggio / Mounting positions

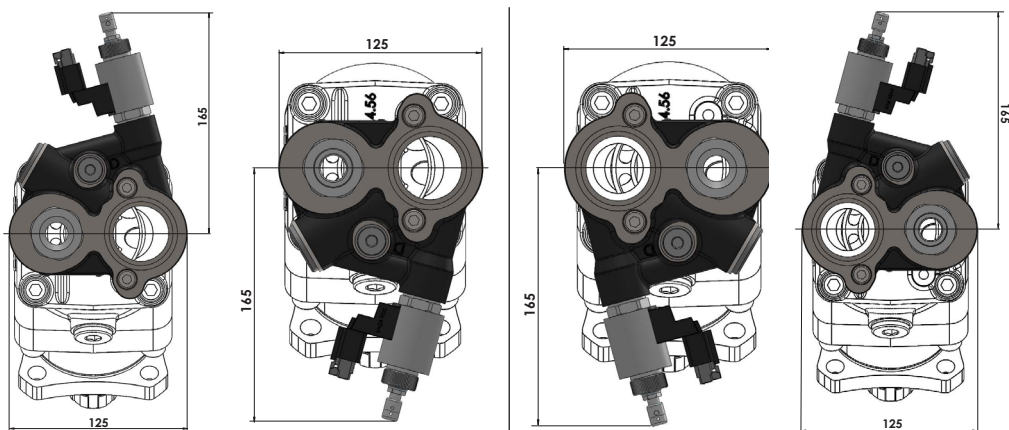

Dati tecnici / Technical features

Tipo pompa Pump type	Codice ordinazione Order code		Pressione max. Max. pressure	IN	OUT	A	D	Peso Weight
	12V	24V						
HDS-40/47/55/64 MDS-80	10820012498	10820024494	400 *	G1-1/4	G3/4	60	G1/4	2,6
HDS-84/108/130 MDS-130	10820012872	10820024878		G1-1/2	G1			
HDT-75/84/96/108	10820012881	10820024887		G1-1/4				

* Vedere catalogo pompe per le pressioni delle singole pompe / See pumps catalogue for related pressure values.

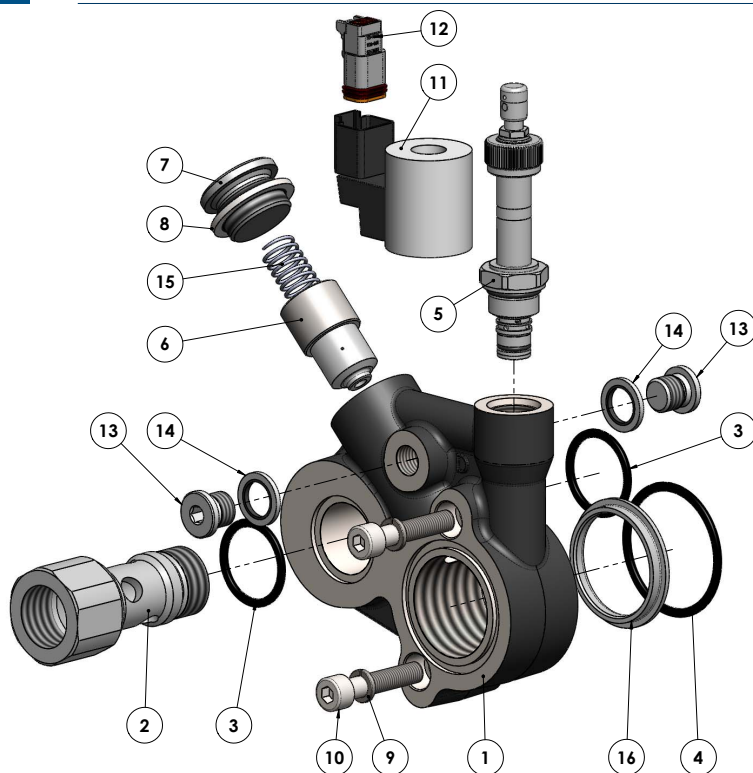

N°	HDS 40/47/55/64 MDS 80	HDS 84-108-130 MDS 130	HDT	Codice Code	Descrizione Description		Q.
1	•			52000000525	Corpo valvola bypass	Bypass body	1
		•	•	52000000534			
			•	52000000543			
2	•			54000500359	Tappo passante	Go-through cap	1
		•	•	54000500537			1
3	•			50600603112	Guarnizione OR	O-Ring	2
		•	•	50600603143			
4	•			50600603181	Guarnizione OR	O-Ring	1
		•	•	50600603200			
5	•	•	•	14901520344	Cartuccia It21 3/4UNF + emergenza. Ricambio ghiera 14995190025	Cartridge It21 3/4 UNF + emergency. Ferrule spare part. 14995190025.	1
6	•	•	•	53600600642	Cursore per valvola bypass	Spool	1
7	•	•	•	11500600144	Tappo cieco acciaio TCE 3/4"	Blank plug TCE 3/4"	1
8	•	•	•	11600910343	Rondella acciaio/gomma	Copper washer	1
9	•	•	•	50100800045	Rondella elastica	Washer	2
10	•	•	•	50200300593	Vite TCE M 8x40	Socket head capscrew	2
11	•	•	•	14917531127	Bobina DEUTSCH 12V	Coil DEUTSCH 12V	1
	•	•	•	14917531245	Bobina DEUTSCH 24V	Coil DEUTSCH 24V	
12	•	•	•	13104500045	Connettore 2 poli DEUTSCH	2-Pole connector DEUTSCH	1
13	•	•	•	11500600117	Tappo cieco acciaio TCE 1/4"	Blank plug TCE 1/4"	2
14	•	•	•	11600910049	Rondella acciaio gomma	Copper washer 1/2	2
15	•	•	•	51200502089	Molla	Spring	1
16		•		53400200677	Anello guida OR	O-R guide ring	1

Tipo pompa Pump type	Kit ricambio guarnizioni Gaskets kit spare part
HDS-40/47/55/64 MDS-80	10890300106
HDS-84/108/130 MDS-130	10890300090
HDT-75/84/96/108	10890300081

Istruzioni di montaggio / Mounting instructions

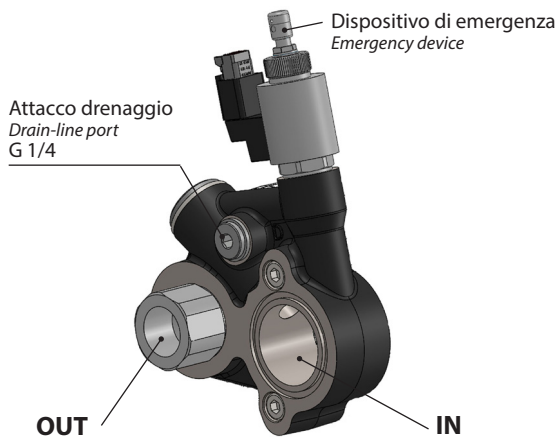

Pompe HDT / HDT Pumps
10820012881
10820024887

Pompe HDS40/47/55/64 MDS80
HDS40/47/55/64 MDS80 Pumps
10820012498
10820024494

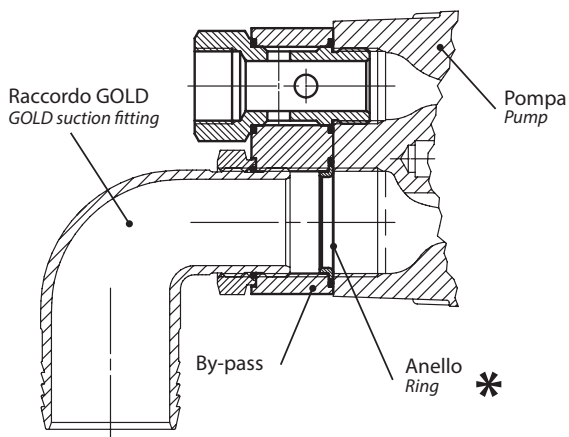
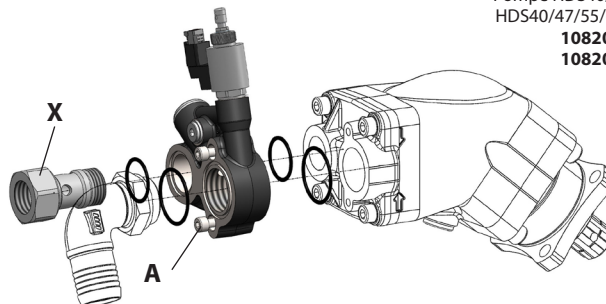

Pompe HDS84/108 MDS130
HDS84/108 MDS130 Pumps
10820012872
10820024878

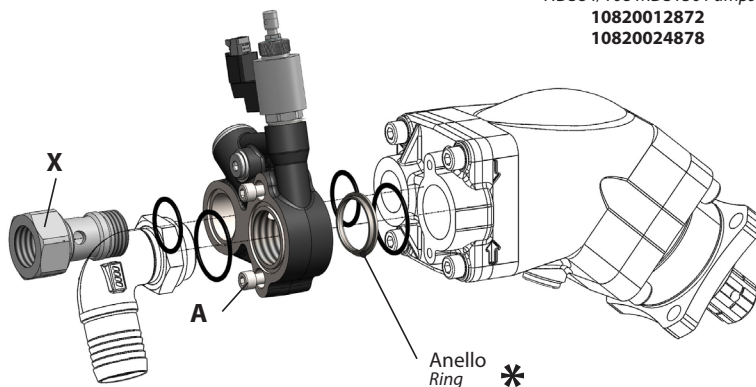

- 1 - Pulire molto bene le superfici della pompa e della valvola che andranno a contatto.
- 2 - Interporre le guarnizioni fornite a corredo (e l'anello * se presente), usando grasso, come indicato in figura.
- 3 - Avvitare la valvola by-pass alla pompa con le viti M8x40 (A) fornite senza serrarle completamente.
- 4 - Avvitare il particolare X (per coppie di serraggio vedi tabella), serrare le viti M8x40 con coppia di serraggio di 25Nm e verificare che la superficie della pompa e la superficie della valvola siano completamente a contatto tra loro.
- 5 - Collegare tubi aspiraz./mandata facendo attenzione ad usare raccordi con lunghezza MAX. filetto L=15mm.
- 6 - Collegamento elettrico: la valvola di by-pass è normalmente aperta. Per utilizzare la pompa in pressione eccitare l'elettrovalvola.

- 1 - Clean the pump and by-pass valve surfaces.
- 2 - Place the o-ring (and the ring * if present) included in the kit as shown in the picture, with grease.
- 3 - Screw in the by-pass valve with included screws M8x40 (A) but without tightening.
- 4 - Screw in X part (see tightening torque in near table), tighten the screws M8x40 with torque 25 Nm checking that valve and rear cover surfaces are completely in contact each other.
- 5 - Connect pressure/suction pipes, paying attention to use maximum lenght threaded fittinge = 15mm.
- 6 - Electrical wiring-up: the by-pass valve is normally open. To deliver oil you have to energise the solenoid valve.

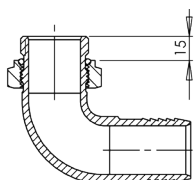

punto/point 5

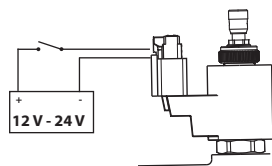

punto/point 6

COPPIE DI SERRAGGIO TIGHTENING TORQUE	
G 1/2	80 Nm
G 3/4	140 Nm
G 1	170 Nm
G 1 1/4	200 Nm
G 1 1/2	250 Nm

ATTENZIONE / WARNING

L'elettrovalvola viene azionata da un interruttore elettrico posto in cabina. La valvola di by-pass viene normalmente impiegata in impianti che prevedono il distributore principale a centro aperto.



Nel caso in cui venga impiegata in impianti con distributore a centro chiuso o nel caso in cui non siano garantiti i 5-10 l/min di portata (Q1) attraverso le tubazioni, è necessario collegare un tubo fra il foro di drenaggio della valvola e il serbatoio.

L'elettrovalvola è dotata di un dispositivo di emergenza in modo che si possa utilizzare la pompa anche in caso di avaria dell'elettrovalvola stessa. Azionamento emergenza di tipo "spingi e gira". La valvola può essere utilizzata indifferentemente per pompe con rotazione destra o sinistra e può essere montata in due diverse posizioni ruotate di 180° in modo da ottimizzarne gli ingombri.

The solenoid valve is operated by an electric switch situated in the cab. The bypass valve is normally used in systems with an open-center main distributor.



If it is used in systems with a closed-center distributor, or if it is impossible to guarantee the minimum flow rate of 5-10 l/min (Q1) through the piping, it becomes necessary to connect a pipe drain valve hole and the tank.

This emergency is "push and twist" type. The solenoid valve is complete with an emergency device so that the pump can be used even in the event of a solenoid valve malfunction. The valve can be used equally for pumps turning either to the right or to the left and it can be installed in two different positions, rotated through 180° so as to make best use of available space.

OPTIONAL

Kit elettrico / Electric kit
Codice / Code **30600102357**



OPTIONAL

Connettore 2 Poli "DEUTSCH" femmina
2-Pole female connector DEUTSCH
Codice / Code **13104500045**

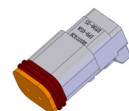

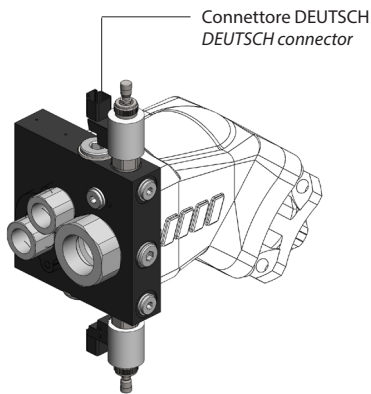

La valvola di by-pass viene utilizzata unitamente alle pompe a pistoni Bent axis "TWIN FLOW" nel caso in cui la pompa sia sempre in rotazione quando il veicolo è acceso (montaggio con prese di forza senza innesto o direttamente sul motore). In questi casi tutto il flusso di olio erogato viene mandato in circolo alla massima portata della pompa, concessa dal numero di giri del motore, attraverso tubazioni che solitamente non sono dimensionate per portate superiori a quelle richieste durante il normale utilizzo della pompa, causando perciò perdite di energia inutili nonché surriscaldamenti dell'impianto. La valvola di by-pass svolge la funzione di ricircolare, **per ogni mandata**, parzialmente il flusso di olio Q della pompa all'interno della pompa stessa in modo che, attraverso le tubazioni dell'impianto, circoli una portata Q1 pari alla differenza fra la portata Q e la portata di riciclo Q2. La ripartizione della portata nei flussi Q1 e Q2 dipende dalle perdite di carico dell'impianto e della valvola di by-pass. È comunque necessario garantire una portata di olio Q1 di almeno 5-10 l/min per assicurare un sufficiente raffreddamento della pompa.

The bypass valve is used together with "TWIN FLOW" bent axis piston pumps if the pump turns constantly when the vehicle is on (in installations with the power takeoff without a coupling or coupled directly to the motor). In such cases, all the oil flow delivered is circulated, at the maximum pump capacity permitted by the turning speed of the motor, through piping that is usually not sized for capacities greater than those required for the normal use of the pump, consequently giving rise to pointless energy losses and overheating in the system. The bypass valve serves the purpose of partially recirculating, **for each delivery**, the pump's oil flow Q inside the pump so that a flow Q1 (corresponding to the difference between the total flow Q and the recycled flow Q2) circulates through the system's piping. The proportion of total capacity distributed to the flows Q1 and Q2 depends on the system load losses and the bypass valve. In any case, it is essential to guarantee an oil flow Q1 of at least 5-10 l/min to ensure adequate pump cooling.

Caratteristiche bobina / Coil features

Assorbimento a 20°C: 20,5W	Power at 20°C: 20,5W
Duty cycle: ED 100%	
Grado di protezione: IP67	Protection class: IP67
Classe di isolamento bobina: H (180°C)	Coil insulation class: H (180°C)
Classe di isolamento cavi rame: H (185°C)	Copper wire insulation: H (185°C)
Trattamento: Zinco-Nichel	Treatment: Zinc-Nichel

Schema idraulico / Hydraulic layout

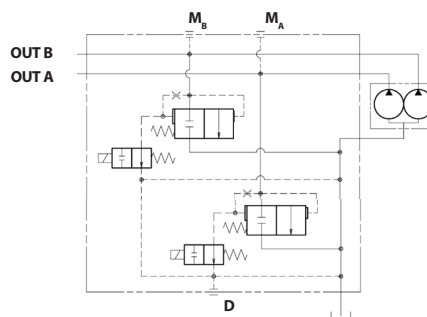

Posizioni di montaggio / Mounting positions

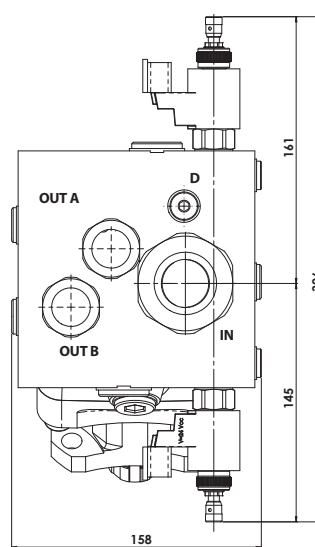
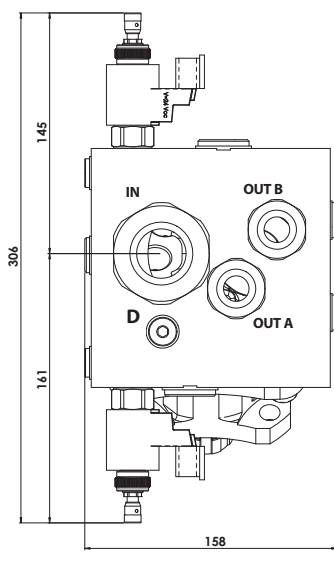

Dati tecnici / Technical features

Tipo pompa Pump type	Codice ordinazione Order code		Pressione max. Max. pressure	Peso Weight
	12V	24V		
TWIN-FLOW 53+53 / 70+35	10820012541	10820024547	400 ✱	6,5
TWIN-FLOW 70+53	10820012710	10820024716		
TWIN-FLOW 76+76	10820012765	10820024761		

✱ Vedere catalogo pompe per le pressioni delle singole pompe / See pumps catalogue for related pressure values.

Codice Code	IN	OUT A OUT B	M _A - M _B	D
10820012541 10820024547	G 1-1/4	G 3/4	G 3/8	G 1/4
10820012710 10820024716	G 1-1/2			

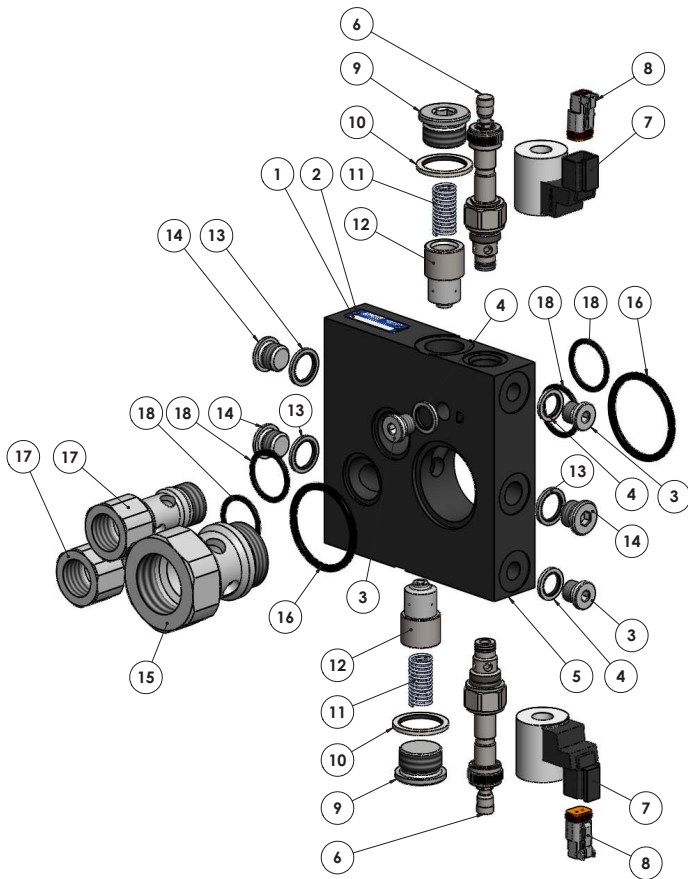

Ingombro / Dimensions

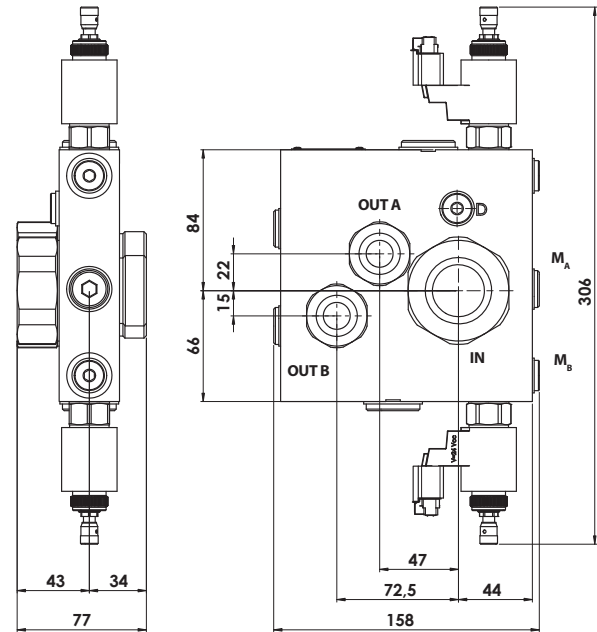

M = attacco manometro / manometer
D = drenaggio / drain

N°	TWIN-FLOW 53+53 / 70+35	TWIN-FLOW 70+53	Codice Code	Descrizione Description	Q.
1	•	•	51300000011	Chiodino fissaggio targhetta Plate nail	2
2	•	•	513	Targhetta completa Plate	1
3	•	•	11500600117	Tappo cieco acciaio TCE 1/4" Blank plug TCE 1/4"	3
4	•	•	11600910049	Rondella acciaio gomma Copper washer	3
5	•	•	52000000552	Corpo valvola bypass Bypass body	1
6	•	•	14901520344	Cartuccia It21 3/4UNF + emergenza. Ricambio ghiera 14995190025 Cartridge It21 3/4 UNF + emergency. Ferrule spare part 14995190025	2
7	•	•	14917531127	Bobina DEUTSCH 12V Coil DEUTSCH 12V	2
	•	•	14917531245	Bobina DEUTSCH 24V Coil DEUTSCH 24V	
8	•	•	13104500045	Connettore 2 poli DEUTSCH 2-Pole connector DEUTSCH	2
9	•	•	11500600144	Tappo cieco acciaio TCE 3/4" Blank plug TCE 3/4"	2
10	•	•	11600910343	Rondella acciaio gomma Copper washer	2
11	•	•	51200502070	Molla Spring	2
12	•	•	53600600642	Cursore per valvola bypass Spool	2
13	•	•	11600910085	Rondella acciaio gomma G3/8 Copper washer G3/8	3
14	•	•	11500600126	Tappo cieco acciaio TCE 3/8" Blank plug TCE 3/8"	3
15	•	•	54000500457	Tappo passante 1 1/4" Go-through cap 1 1/4"	1
	•	•	54000500466	Tappo passante 3/4" Go-through cap 3/4"	
16	•	•	50600604200	Guarnizione OR O-Ring	2
17	•	•	54000500359	Tappo passante 3/4" Go-through cap 3/4"	2
18	•	•	50600603112	Guarnizione OR O-Ring	4

Tipo pompa Pump type	Kit ricambio guarnizioni Gaskets kit spare part
TWIN-FLOW 53+53 / 70+35 TWIN-FLOW 70+53	10890300115

Codice Code	IN	OUT A OUT B	M _A - M _B	D
10820012765	G 1-1/2	G 3/4	G 3/8	G 1/4
10820024761				

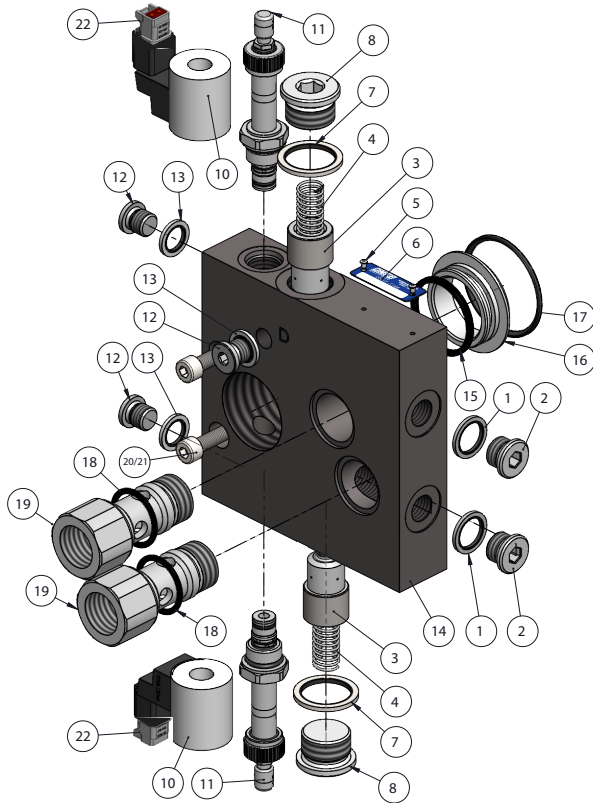

Ingombro / Dimensions

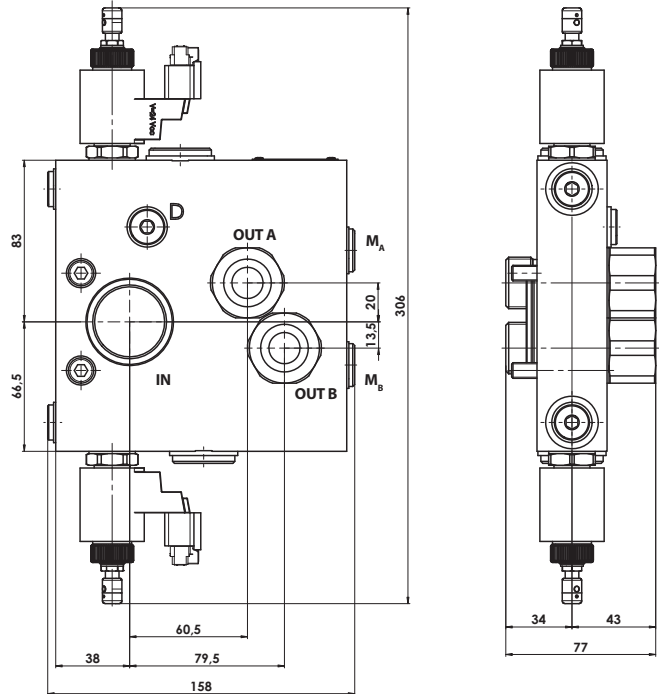

M = attacco manometro / manometer
D = drenaggio / drain

N°	TWIN-FLOW 76+76	Codice Code	Descrizione Description		Q.
1	•	11600910085	Rondella acciaio gomma G3/8	Copper washer G3/8	2
2	•	11500600126	Tappo cieco acciaio TCE 3/8"	Blank plug TCE 3/8"	2
3	•	53600600642	Cursore per valvola bypass	Spool	2
4	•	51200502070	Molla	Spring	2
5	•	51300000011	Chiodino fissaggio targhetta	Plate nail	2
6	•	513	Targhetta completa	Plate	1
7	•	11600910343	Rondella acciaio gomma	Copper washer	2
8	•	11500600144	Tappo cieco acciaio TCE 3/4"	Blank plug TCE 3/4"	2
10	•	14917531127	Bobina DEUTSCH 12V FERRO	Coil DEUTSCH 12V	2
		14917531245	Bobina DEUTSCH 24V FERRO	Coil DEUTSCH 24V	
11	•	14901520344	Cartuccia It21 3/4UNF + emergenza. Ricambio ghiera 14995190025	Cartridge It21 3/4 UNF + emergency. Ferrule spare part 14995190025	2
12	•	11500600117	Tappo cieco acciaio TCE 1/4"	Blank plug TCE 1/4"	3
13	•	11600910049	Rondella acciaio gomma	Copper washer	3
14	•	52000000829	Corpo valvola bypass	Bypass body	1
15	•	50600600207	Guarnizione OR 142	OR 142 gasket	1
16	•	53400200864	Anello guida	Centering ring	1
17	•	50600015230	Guarnizione OMR 0520-30 HNBR	OMR 0520-30 HNBR gasket	1
18	•	50600603112	Guarnizione OR	O-Ring	4
19	•	54000500359	Tappo passante 3/4"	Go-through cap 3/4"	2
20	•	50200300593	Vite TCE UNI5931 M8	TCE UNI5931 M8 screw	2
21	•	50100800045	Rondella elastica per M8 DIN7980	Washer fro M8 DIN7980	2
22	•	13104500045	Connettore 2 poli DEUTSCH	2-pole connector DEUTSCH	2

Tipo pompa Pump type	Kit ricambio guarnizioni Gaskets kit spare part
TWIN-FLOW 76+76	10890300151

Istruzioni di montaggio / Mounting instructions

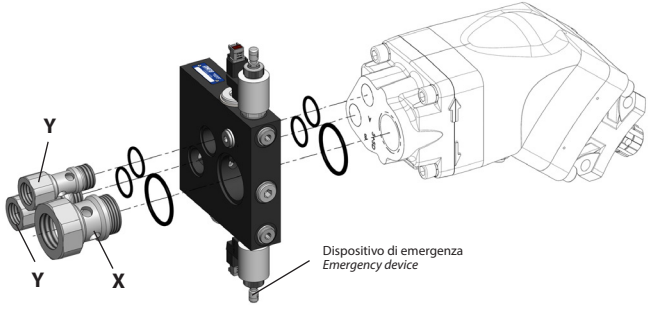
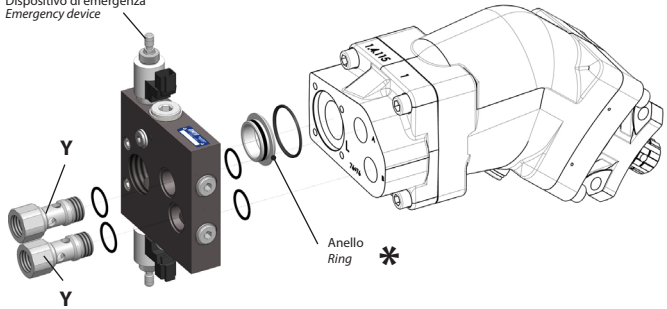
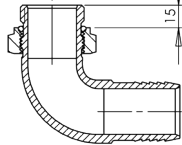
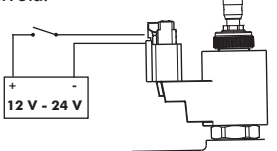
TWIN-FLOW 53+53 - 70+35 - 70+53	TWIN-FLOW 76+76
 <p>Dispositivo di emergenza Emergency device</p>	 <p>Dispositivo di emergenza Emergency device</p> <p>Anello Ring *</p>
<p>1 - Pulire molto bene le superfici della pompa e della valvola che andranno a contatto. / Clean the pump and by-pass valve surfaces.</p>	
<p>2 - Interporre le guarnizioni fornite a corredo come indicato in figura. Place the o-ring included in the kit as shown in the picture.</p>	<p>- Interporre le guarnizioni e l'anello * forniti a corredo come indicato in figura. Place the o-rings and the ring * included in the kit as shown in the picture.</p>
<p>3 - Avvitare il particolare X ed i particolari Y (Coppie di serraggio in tabella). Screw in X part and Y parts (See tightening torque in table).</p>	<p>- Avvitare il corpo ed i particolari Y (Coppie di serraggio in tabella). Screw in the body and the Y parts (See tightening torque in table).</p>
<p>4 - Collegare tubi aspiraz./mandata. Connect pressure/suction pipes.</p>	<p>- Collegare tubi aspiraz./mandata facendo attenzione ad usare raccordi con lunghezza MAX. filetto L=15mm. Connect pressure/suction pipes, paying attention to use MAXIMUM length threaded fittings = 15mm.</p> 
<p>5 - Collegamento elettrico: la valvola di by-pass è normalmente aperta. Per utilizzare la pompa in pressione eccitare l'elettrovalvola. Electrical wiring-up: the by-pass valve is normally open. To deliver oil you have to energise the solenoid valve.</p> 	

OPTIONAL
Kit elettrico / Electric kit
Codice / Code 30600102357

L=6000mm



OPTIONAL
Connettore 2 Poli "DEUTSCH" femmina
2-Pole female connector DEUTSCH
Codice / Code 13104500045

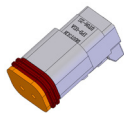

COPPIE DI SERRAGGIO COPPIE DI SERRAGGIO	
G 1/2	80Nm
G 3/4	140Nm
G 1	170Nm
G 1 1/4	200Nm
G 1 1/2	250Nm

ATTENZIONE / WARNING

L'elettrovalvole vengono azionate da interruttori elettrici posti in cabina. La valvola di by-pass viene normalmente impiegata in impianti che prevedono il distributore principale a centro aperto.



Nel caso in cui venga impiegata in impianti con distributore a centro chiuso o nel caso in cui non siano garantiti i 5-10 l/min di portata (Q1) attraverso le tubazioni, è necessario collegare un tubo da 3/8" fra il raccordo ausiliario della valvola e il serbatoio (utilizzare raccordo G1/4 incluso nella confezione).

L'elettrovalvole sono dotate di un dispositivo di emergenza in modo che si possa utilizzare la pompa anche in caso di avaria dell'elettrovalvole stesse. La valvola può essere utilizzata indifferentemente per pompe con rotazione destra o sinistra e può essere montata in due diverse posizioni ruotate di 180° in modo da ottimizzarne gli ingombri. Ai raccordi da 3/8" è possibile collegare dei manometri per la misura delle pressioni.

The solenoid valves are operated by electric switches situated in the cab. The bypass valve is normally used in systems with an open-center main distributor.



If it is used in systems with a closed-center distributor, or if it is impossible to guarantee the minimum flow rate of 5-10 l/min (Q1) through the piping, it becomes necessary to connect a 3/8" pipe between the valve's auxiliary connection and the tank (use the fitting G1/4 included in the package).

The solenoid valves are completed with an emergency device so that the pump can be used even in the event of a solenoid valves malfunction. The valve can be used equally for pumps turning either to the right or to the left and it can be installed in two different positions, rotated through 180° so as to make best use of available space. A pressure gauge can be connected to the 3/8" connection to enable pressure measurements.

PANNELLO CON VALVOLA DI MASSIMA PER POMPE SERIE "HDS-MDS-HDT"

CODICE FAMIGLIA
FAMILY CODE

108205

RELIEF VALVE ASSEMBLY FOR "HDS-MDS-HDT" BENT AXIS PISTON PUMPS

99740060010

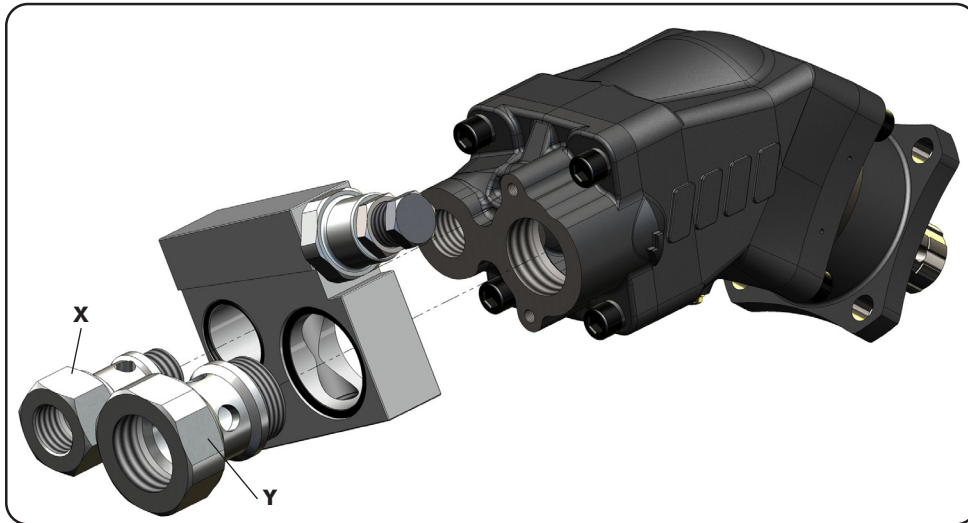

Schema idraulico
Hydraulic scheme

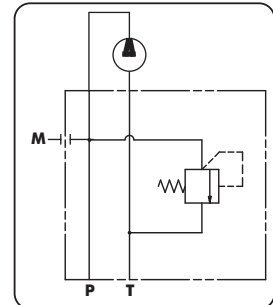

La valvola si applica **direttamente** sul corpo posteriore della pompa in modo che **scarichi direttamente in aspirazione alla stessa senza rendere necessario il tubo verso serbatoio**. La valvola protegge la pompa da sovrappressioni dovute ad azionamenti errati o a impianti lasciati involontariamente con valvole chiuse o con tubi innesto rapidi non collegati. Il fissaggio della valvola sulla pompa è simmetrico, quindi è possibile ruotarla di 180° in modo da evitare possibili interferenze sul veicolo.

This valve can be **directly** fitted on the rear cover of the pump in such a way that **the return flow goes back to tank through the pump itself saving one hose**. The valve protects the pump from peak pressure due to any wrong operations such as closed circuit or coupling not connected. The fitment of the relief valve assembly onto the pump is symmetric, thus it is possible to rotate it by 180° just to avoid any interferences.

Tipo pompa / Pump type	Codice / Code	IN	OUT	Pressione di taratura Setting pressure	
				minima / min.	massima / max.
HDS 40 - HDS 47 - HDS 55 HDS 64 - MDS 80	10820500479	G 1 1/4"	G 3/4"	45 ± 5 bar	360 ± 5 bar
HDS 84	10820500844	G 1 1/4"	G 1"		
HDS 108 MDS 130	10820501085	G 1 1/2"	G 1"		
HDT 75 - HDT 84 HDT 96 - HDT 108	10820550843	G 1 1/4"	G 1"		

Ingombro HDS - MDS / HDS - MDS Dimension

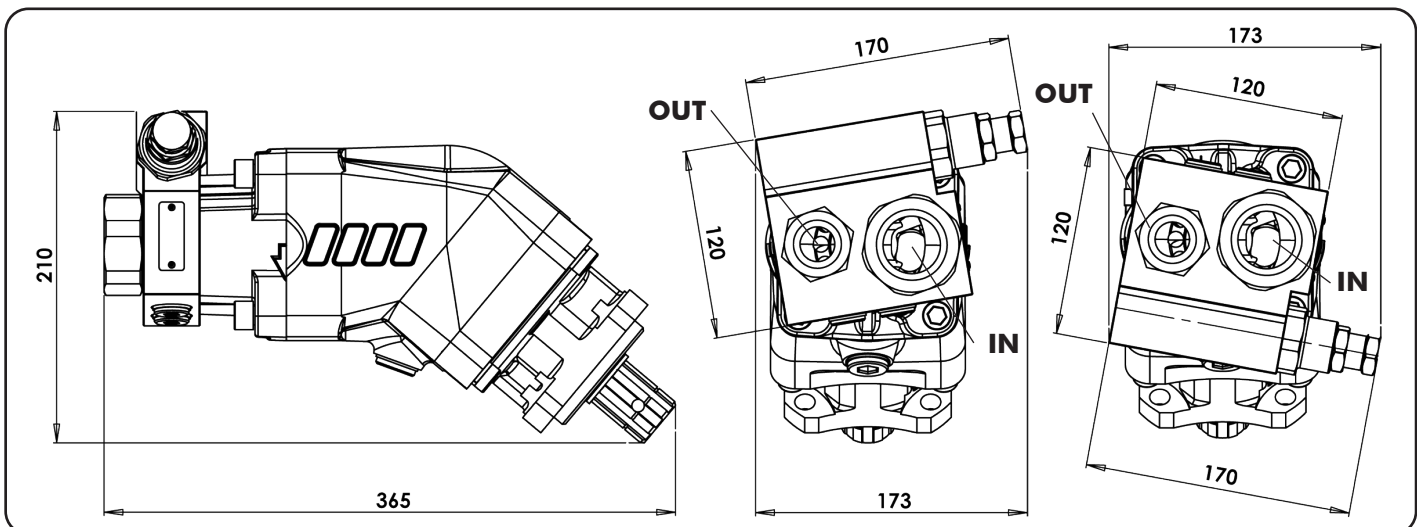

09/08/2012

99710820510 Rev: AC

pag.89

O.M.F.B. S.p.A. Hydraulic Components

We reserve the right to make any changes without notice.

Edition 2016.06 No reproduction, however partial, is permitted.

Via Cave, 7/9 25050 Provaglio d'Iseo (Brescia) Italy Tel.: +39.030.9830611
Fax: +39.030.9839207-208 Internet:www.omfb.it e-mail:contatti@omfb.it

COMPANY WITH
QUALITY SYSTEM
CERTIFIED BY DNV GL
= IATF 16949 =



Ingombro HDT / HDT Dimension

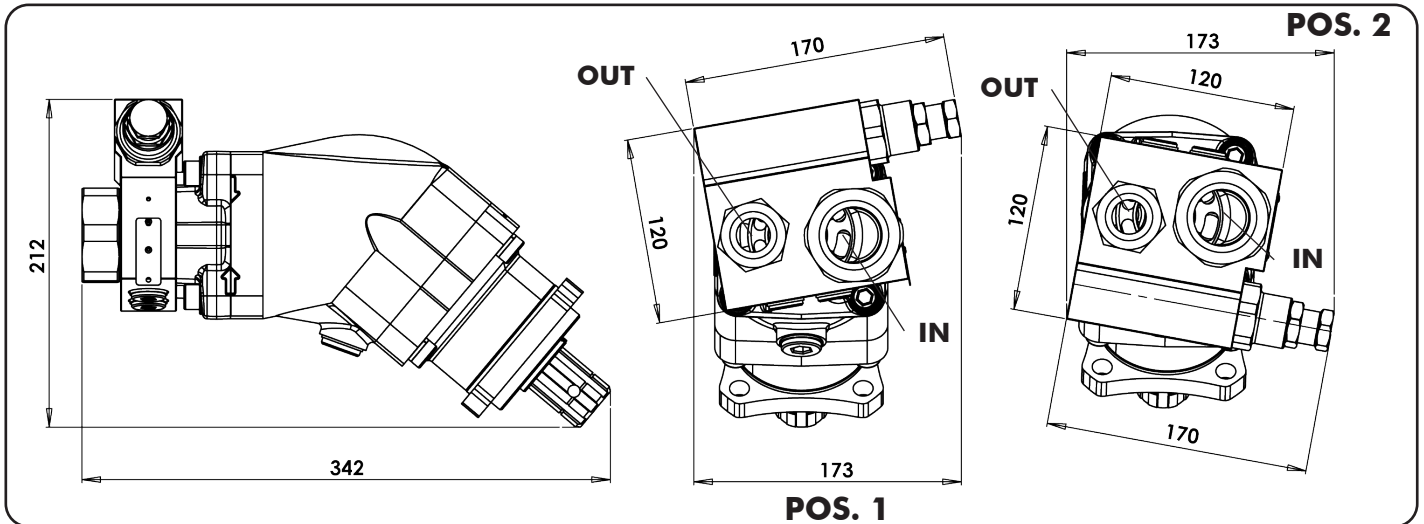

99740060010

ISTRUZIONI DI MONTAGGIO / MOUNTING INSTRUCTIONS

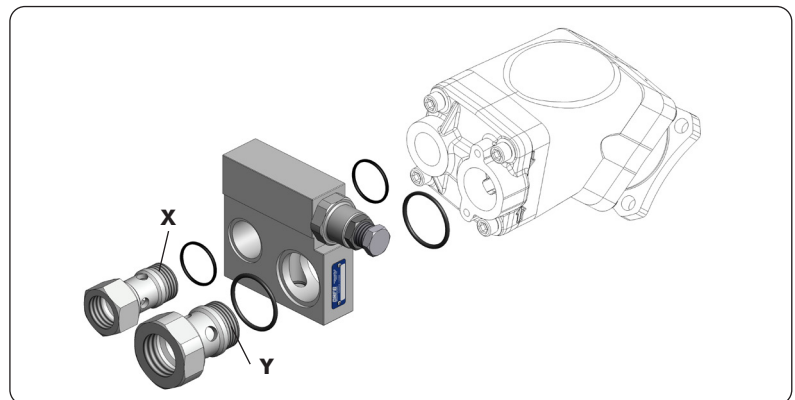
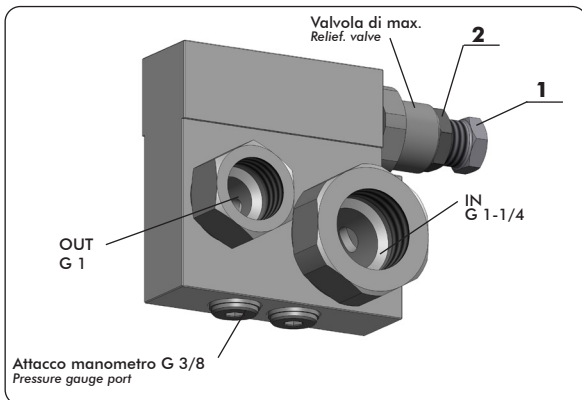

- 1 - Pulire molto bene le superfici della pompa e della valvola che andranno a contatto.
Clean the pump and by-pass valve surfaces.
- 2 - Interporre le guarnizioni (o-ring) fornite a corredo come indicato in figura.
Place the o-ring included in the kit as shown in the picture.
- 3 - Avvitare il particolare X ed il particolare Y (Coppie di serraggio vedi tabella a fianco).
Screw in X part and Y part (See tightening torque in near table).
- 4 - Collegare tubi aspirazione/mandata.
Connect pressure/suction pipe.

COPPIE DI SERRAGGIO TIGHTENING TORQUE	
G 1/2	80Nm
G 3/4	140Nm
G 1	170Nm
G 1 1/4	200Nm
G 1 1/2"	250Nm

TARATURA VALVOLA DI MASSIMA / RELIEF VALVE SETTING

ATTENZIONE / WARNING



La valvola è tarata a **250 bar**. Se necessari valori diversi, agire come segue:
The relief valve is set at **250 bar**. If necessary please set a new value as follows:

A) Svitare il part. 2 avendo cura di mantenere in posizione il part. 1.
Unscrew the part. 2 carefully keeping the part. 1 tight.

B) REGOLAZIONE / SETTING:

Avvitando il particolare 1 la pressione aumenta.
Svitando la pressione diminuisce.
*The pressure increases while **Screwing** the part. 1.
The pressure decreases while **Unscrewing**.*
Controllare la pressione con un manometro.
Check the pressure setting with a pressure gauge.

C) Riavvitare il part. 2 mantenendo in posizione il part. 1.
Lock the part. 2 paying attention to keep into position the part 1.

pag.90

09/08/2012

99710820510 Rev. AC

KIT RACCORDI PER ASPIRAZIONE E MANDATA

SUCTION AND DELIVERY FITTINGS KITS

CODICE FAMIGLIA
FAMILY CODE

155

KIT RACCORDI FITTING KITS

99740060010

**"GOLD" 45°
45° "GOLD"**



FILETTO THREAD ISO 228	D (Internal pipe diameter)		DE (External pipe diameter)		CH mm	V mm	CODICE CODE	PESO WEIGHT kg
	mm	inch	Min mm	Max mm				
G 1	38	1"1/2	48	51	41	111	15509000460	0,6270
	40		48	51		112,5	15509000488	0,6610
			52	55			15509000479	0,7100
G 1 1/4	38	1"1/2	48	51	50	104	15509000490	0,6570
	40		48	51			15509000493	0,7010
			52	55			15509000494	0,7370
	50	2"	60	63		114	15509000497	0,7960
	60		64	67			15509000504	0,8030
			68	73			128	15509000522
G 1 1/2	63	2"1/2	74	79	55	130	15509000531	1,0600
			60	63		15509000540	0,7940	
	64	67	128	15509000559		0,8260		
G 1 1/2	60	2"	68	73	55	108	15509000611	1,0110
			63	79			130	15509000620

**"GOLD" 90°
90° "GOLD"**



FILETTO THREAD ISO 228	D (Internal pipe diameter)		DE (External pipe diameter)		CH mm	V mm	CODICE CODE	PESO WEIGHT kg		
	mm	inch	Min mm	Max mm						
G 1/2	40		48	51	28	48	15510000083	0,5750		
			52	55			15510000092			
			32	35			15510000118	0,2740		
	32	1"1/4	36	39		40	15510000127	0,2660		
			40	43			15510000145	0,3740		
			44	47			15510000154	0,3790		
G 3/4	19	3/4"	29	31	34	45	15510000172	0,3450		
	25	1"	32	35			15510000181	0,3550		
			36	39			15510000190	0,3580		
	32	1"1/4	40	43		49	15510000207	0,4490		
			44	47			15510000216	0,4670		
	G 1	38	1"1/2	48		51	41	51	15510000252	0,5580
40					52	55			15510000270	0,6040
		40	43		15510000289	0,6300				
G 1		32	1"1/4	44	47	54		54	15510000323	0,6320
				38	1"1/2				48	51
		44	47						15510000350	0,6400
	45	1" 3/4	52	55	67		15510000378	0,6830		
			56	59			15510000387	0,7210		
	50	2"	60	63	50		60	15510000396	0,8070	
64			67	15510000403		0,7960				
60		68	73	15510000412		0,9550				
		64	67	15510000421		0,9770				
G 1 1/4	38	1"1/2	48	51		55	63	15510000430	1,2350	
			40					48	51	15510000458
	52	55			15510000467			0,7750		
	45	1" 3/4	56	59	65		15510000476	0,8200		
			60	63			15510000485	0,9390		
	60	2"	64	67	60		15510000494	0,9160		
68			73	15510000501		0,8710				
63	2"1/2	74	79	15510000510		0,8770				
		52	55	15510000529		1,1640				
G 1 1/2	45	1" 3/4	56	59		55	60	15510000538	1,2300	
			60	63				15510000547	1,0690	
	64	67	15510000556	1,0570						
	60	2"	68	73	63		15510000592	0,9900		
			74	79			15510000609	0,9906		
	63	2"1/2	74	79	65		15510000654	1,0680		
74			79	15510000663		1,1820				

KIT RACCORDI PER **ASPIRAZIONE E MANDATA** SUCTION AND DELIVERY FITTINGS KITS

KIT RACCORDI **FITTING KITS**

	FILETTO THREAD ISO 228	Diametro interno tubo Internal pipe diameter mm		Diametro esterno tubo External pipe diameter mm		CH mm	CODICE CODE
		MIN	MAX	MIN	MAX		
ASPIRAZIONE / SUCTION "GOLD" 90° FILETTO FILETTO 90° "GOLD" ON BOYH SIDES 	G 3/4 x G 3/4					34	15511000107
	G 1 x G 1					41	15511000125
	G 1 1/4 x G 1 1/4					50	15511000143
	G 1 1/2 x G 1 1/2					55	15511000161
	G 1 1/2 x G 1 1/4					50 55	15511000303

	FILETTO THREAD ISO 228	Diametro interno tubo Internal pipe diameter mm	CH mm	CODICE CODE
		mm		
MANDATA DELIVERY  RACCORDO AD ALTA PRESSIONE 90° HIGH PRESSURE FITTING 90°	G 1/2 x 1/2		27	15520000126
	G 3/4 x 3/4		32	15520000340
	G 3/4 x 1		32-38	15520034100
	G 1 x 1		38	15520001009
	G 1 x 3/4		38-32	15520010348

99740060010