



Pilot Operated Check Valves Technical Information

Reverse Pilot to Open

CP458-2

OPERATION

This valve is a pilot-to-open check valve.

Schematic

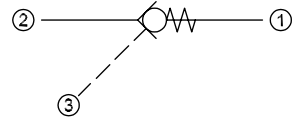

SPECIFICATIONS

Theoretical performance

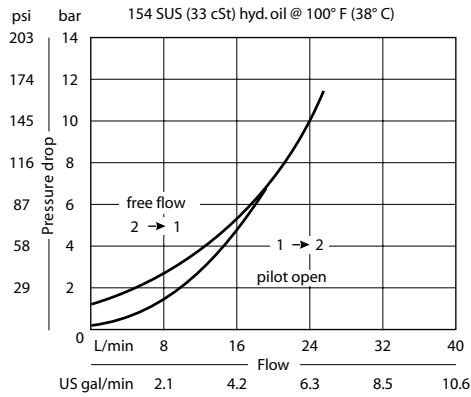

Specifications

Rated pressure	210 bar [3000 psi]
Rated flow at 7 bar [100 psi]	20 l/min [5 US gal/min]
Leakage	6 drops/min @ Rated pressure
Weight	0.07 kg [0.15 lb]
Pilot ratio	2.8:1
Cavity	SDC08-3

Note: A piston seal requires a 4.5 bar [65 psi] or greater return spring.

DIMENSIONS

mm [in]

Cross-sectional view

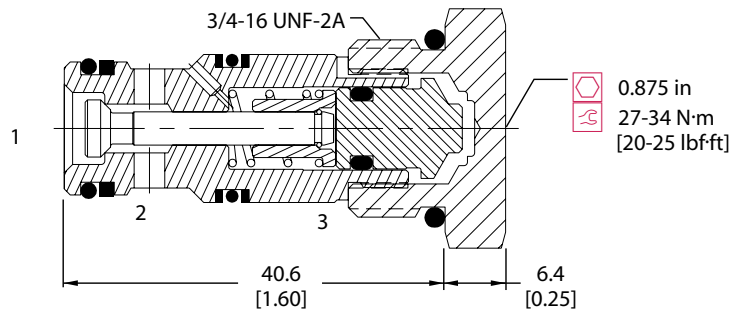

ORDERING INFORMATION

CP458 - 2 - B - 6S - 065 - 0

Seals B = Buna-N V = Viton	Seal kit 120250 120253	Piston seals 0 = No seals S = Seals included
Housing and ports 0 = No Housing SE2B = Al, 1/4 BSP SE3B = Al, 3/8 BSP 4S = Al, #4 SAE 6S = Al, #6 SAE Other housings available	Housing P/N No Housing SDC08-3-SE-2B SDC08-3-SE-3B CP08-3-4S CP08-3-6S	Crack Pressure bar [psi] 065 = 4.48 [65]