

RF2 series

Maximum working pressure up to 2 MPa (20 bar) - Flow rate up to 350 l/min



Description

Technical data

Return filter

Maximum working pressure up to 2 MPa (20 bar)
Flow rate up to 350 l/min

RF2250 and RF2350 are ranges of return filters for side tank mounting with integrated shut-off valve for protection of the reservoir against the system contamination.

They are placed below the minimum oil level, directly connected to the return line of the system.

The shut-off valve closes automatically when the cover is removed, allowing the filter element replacement without the fluid drop.

Available features:

- Female threaded connections up to 1" and flanged connections up to 1 1/2", for a maximum flow rate of 350 l/min
- Bypass valve, to relieve excessive pressure drop across the filter media
- Magnetic column, to hold the ferrous particles
- Visual, electrical and electronic clogging indicators

Common applications:

- Compact mobile machines
- Compact industrial equipment

Filter housing materials

- Filter body: Aluminium
- Cover: Polyamide, GF reinforced
- Valve: Polyamide, GF reinforced - Steel
- Anti-Emptying valve: Steel

Bypass valve

Opening pressure 175 kPa (1.75 bar) \pm 10%

Δp element type

- Microfibre filter elements - series CU: 10 bar
- Fluid flow through the filter element from OUT to IN

Seals

- Standard NBR series A
- Optional FPM series V

Temperature

From -25 °C to +110 °C

Note

RF2 250-350 filters mounting, see the drawings on page 235 and following



Weights [kg] and volumes [dm³]

Filter series	Weights [kg]		Volumes [dm ³]	
	Length	1	Length	1
RF2 250		2.6		2.0
RF2 350		2.8		2.0

Filter housings Δp pressure drop

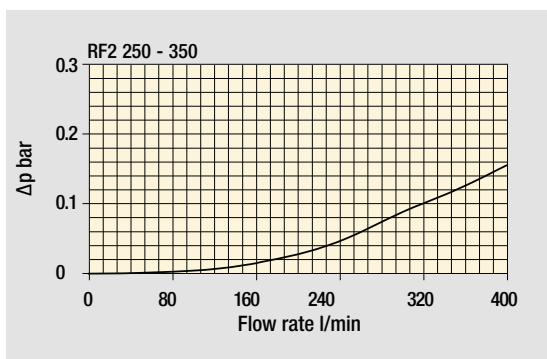

Bypass valve pressure drop

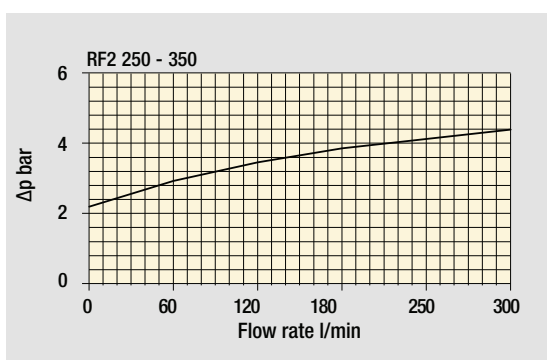

The curves are plotted using mineral oil with density of 0.86 kg/dm³ in compliance with ISO 3968. Δp varies proportionally with density.

Flow rates [l/min]

Filter series	Length	Filter element design - N Series							
		A03	A06	A10	A16	A25	M25 M60 M90	P10	P25
RF2 250	1	148	184	278	307	447	615	447	485
RF2 350	1	148	184	278	307	447	615	447	485

Maximum flow rate for a complete return filter with a pressure drop $\Delta p = 0.5$ bar.

The reference fluid has a kinematic viscosity of 30 mm²/s (cSt) and a density of 0.86 kg/dm³.

For different pressure drop or fluid viscosity we recommend to use our selection software available on www.mpfiltri.com.

Please, contact our Sales Department for further additional information.

Hydraulic symbols

Filter series	Style B - E
RF2 250	•
RF2 350	•

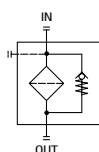

RF2 RF2250 - RF2350

Designation & Ordering code

COMPLETE FILTER

Series and size

RF2250
RF2350

Configuration example 1: **RF2250** **W** **F2** **E** **M25** **P01**

Configuration example 2: **RF2350** **A** **G1** **B** **A25** **P01**

Seals and treatments	Filtration rating		
	Axx	Mxx	Pxx
A NBR	•	•	•
V FPM	•	•	•
W NBR compatible with fluids HFA-HFB-HFC	•	•	
Z FPM compatible with fluids HFA-HFB-HFC	•	•	

Connections	Aux (only RF2350)	Mxx	Pxx
G1 G 1 1/2"	G 1"	•	•
G2 1 1/2" NPT	-	•	
G3 SAE 24 - 1 7/8" - 12 UN	SAE 16 - 1 5/16" - 12 UN	•	•
G4 G 1 1/4"	-	•	
G5 1 1/4" NPT	-	•	
G6 SAE 20 - 1 5/8" - 12 UN	-	•	
G7 G 1"	-	•	
G8 1" NPT	-	•	
G9 SAE 16 - 1 5/16" - 12 UN	-	•	
F1 1 1/2" SAE 3000 psi/M	-	•	
F2 1 1/2" SAE 3000 psi/UNC	-	•	

Bypass valve

B 1.75 bar
E 3 bar

Filtration rating (filter media)

A03 Inorganic microfiber 3 µm	M25 Wire mesh 25 µm
A06 Inorganic microfiber 6 µm	M60 Wire mesh 60 µm
A10 Inorganic microfiber 10 µm	M90 Wire mesh 90 µm
A16 Inorganic microfiber 16 µm	P10 Resin impregnated paper 10 µm
A25 Inorganic microfiber 25 µm	P25 Resin impregnated paper 25 µm

Execution

P01 MP Filtri standard
Pxx Customized

FILTER ELEMENT

Element series and size

CU250

Configuration example 1: **CU250** **M25** **W** **P01**

Configuration example 2: **CU250** **A25** **N** **P01**

Filtration rating (filter media)

A03 Inorganic microfiber 3 µm	M25 Wire mesh 25 µm
A06 Inorganic microfiber 6 µm	M60 Wire mesh 60 µm
A10 Inorganic microfiber 10 µm	M90 Wire mesh 90 µm
A16 Inorganic microfiber 16 µm	P10 Resin impregnated paper 10 µm
A25 Inorganic microfiber 25 µm	P25 Resin impregnated paper 25 µm

Seals and treatments	Filtration rating		
	Axx	Mxx	Pxx
N NBR	•	•	•
V FPM	•	•	•
W NBR head anodized filter element compatible with fluids HFA-HFB-HFC	•	•	
Z FPM head anodized filter element compatible with fluids HFA-HFB-HFC	•	•	

Execution

P01 MP Filtri standard
Pxx Customized

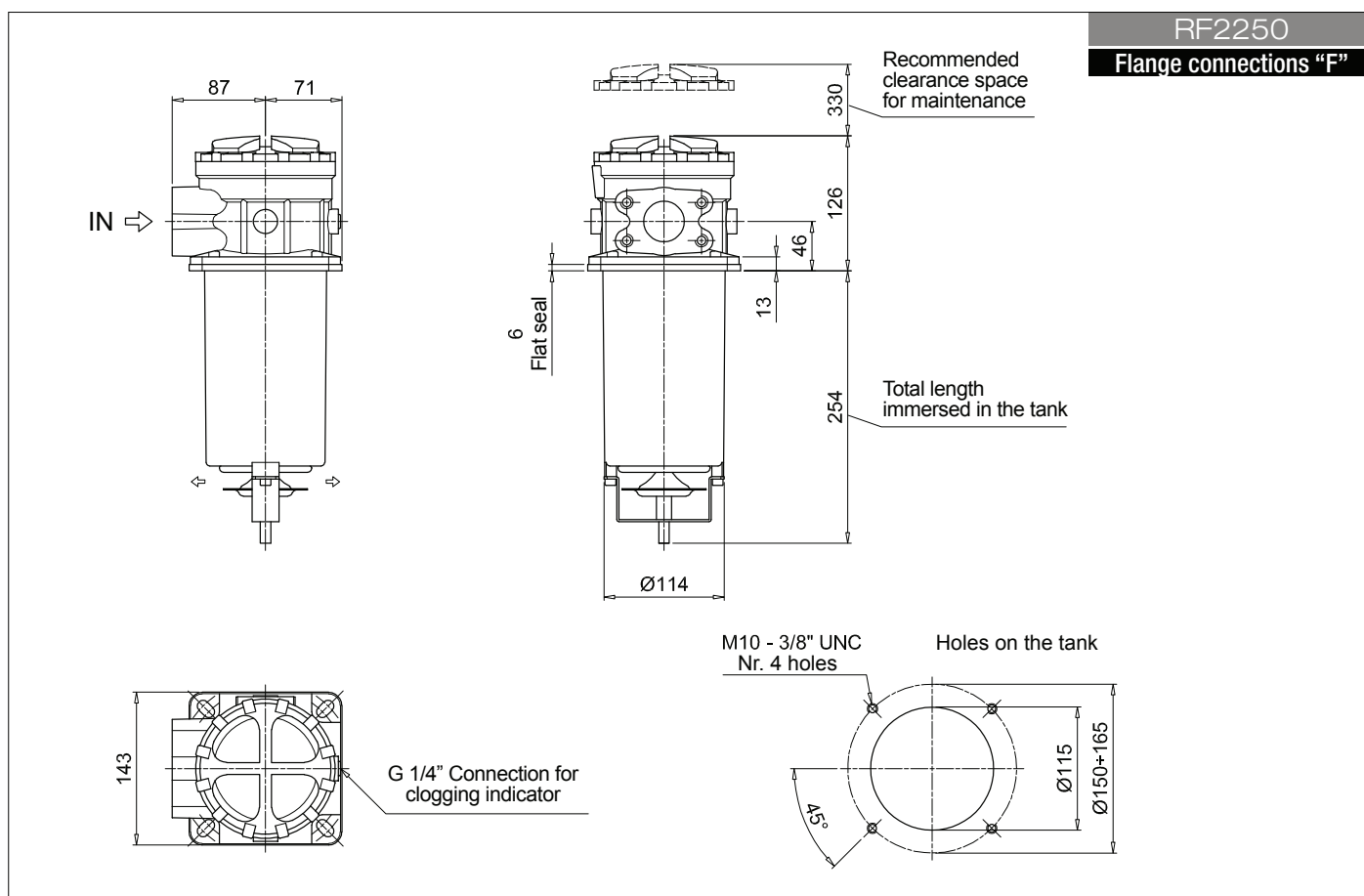
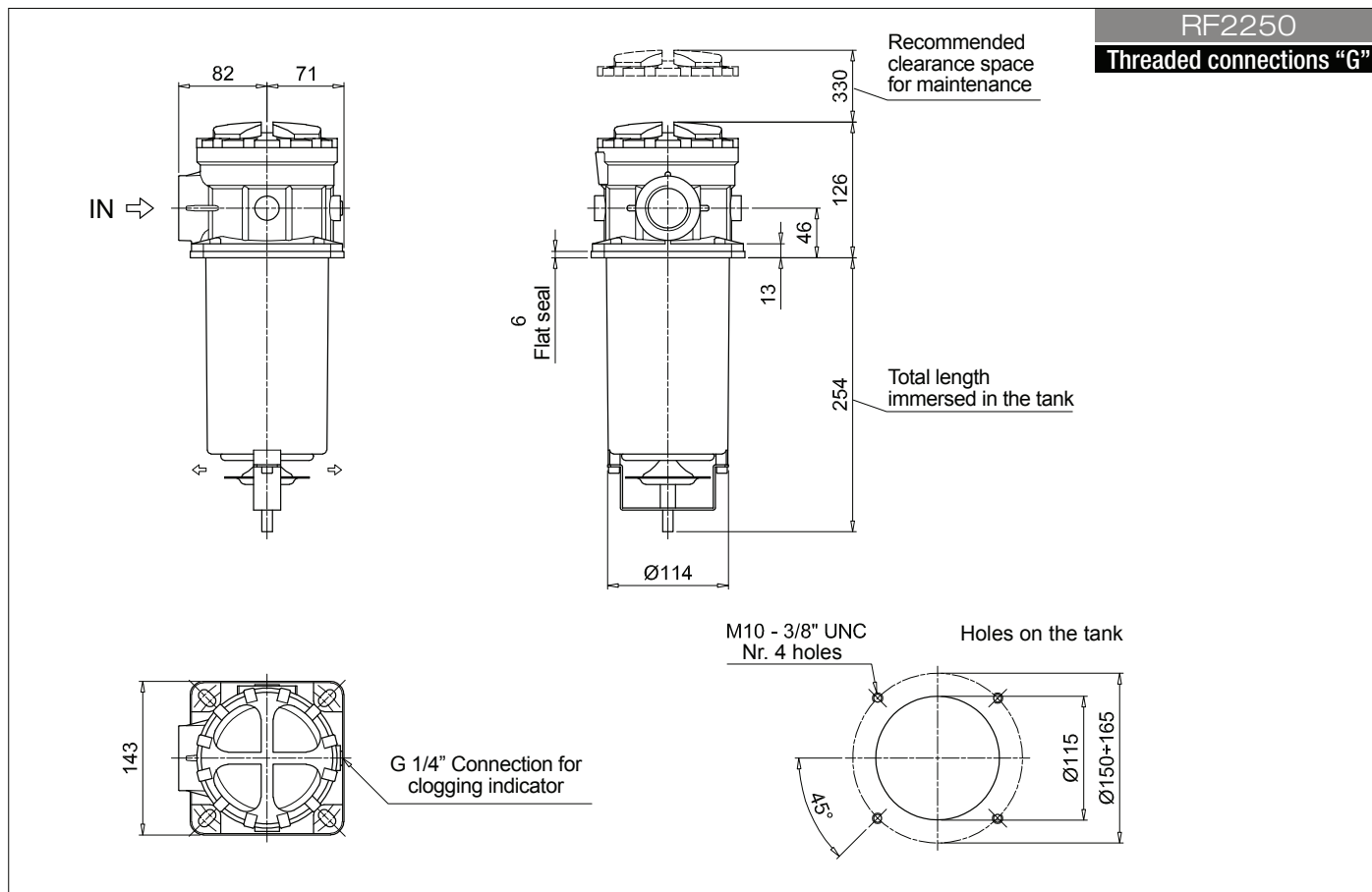

RF2 RF2250 - RF2350

Dimensions

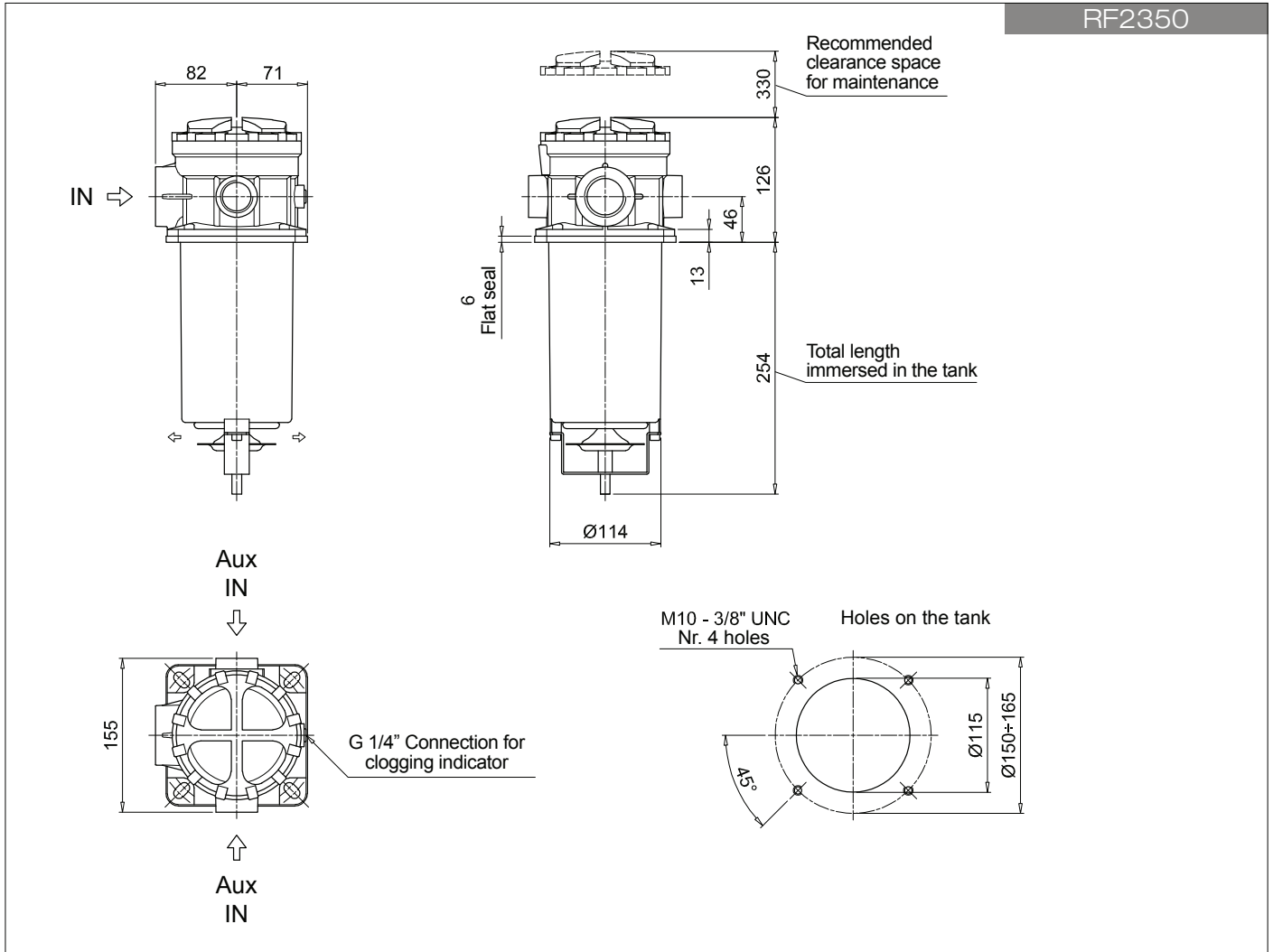

RF2 250 - 350

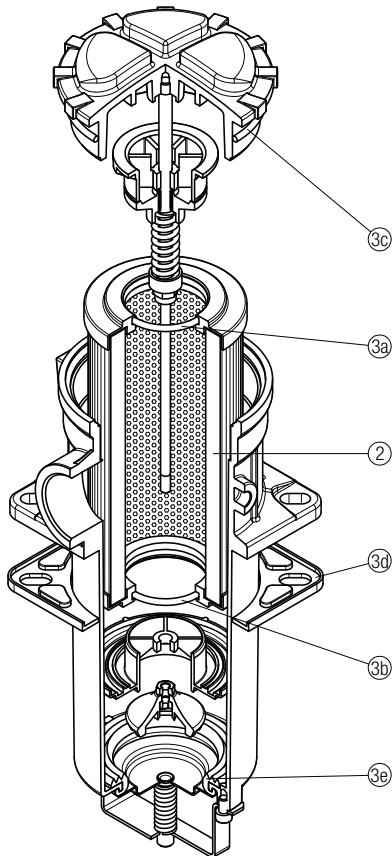

Item:	Q.ty: 1 pc.	Q.ty: 1 pc.	
Filter series	Filter element	Seal Kit code number	
		NBR	FPM
RF2 250	See order table	02050586	02050587
RF2 350			