

# FMM series

Maximum working pressure up to 42 MPa (420 bar) - Flow rate up to 250 l/min



## Description

## Technical data

### High Pressure filters

#### In-line

**Maximum working pressure up to 42 MPa (420 bar)**

**Flow rate up to 250 l/min**

FMM is a range of versatile high pressure filter for protection of sensitive components in high pressure hydraulic systems in the mobile machines.

They are directly connected to the lines of the system through the hydraulic fittings.

#### Available features:

- Female threaded connections up to 1 1/4", for a maximum flow rate of 250 l/min
- Fine filtration rating, to get a good cleanliness level into the system
- Bypass valve, to relieve excessive pressure drop across the filter media
- Low collapse filter element "N", for use with filters provided with bypass valve
- Low collapse filter element with external support "R", for filter element protection against the back pressure caused by the check valve in filters provided with the bypass valve
- High collapse filter element with external support "S", for filter element protection against the back pressure caused by the check valve in filters not provided with the bypass valve
- Visual, electrical and electronic differential clogging indicators

#### Common applications:

- Agricultural machines
- Mobile machines

#### Filter housing materials

- Head  
Phosphatized cast iron: FMM 050  
Painted cast iron: FMM 150
- Housing: Phosphatized steel
- Bypass valve: Steel

#### Pressure

- Test pressure: 63 MPa (630 bar)
- Burst pressure: 126 MPa (1260 bar)
- Pulse pressure fatigue test: 1 000 000 cycles with pressure from 0 to 42 MPa (420 bar)

#### Bypass valve

- Opening pressure 600 kPa (6 bar) ±10%
- Other opening pressures on request.

#### Δp element type

- Microfiber filter elements - series N-R: 20 bar
- Microfiber filter elements - series S: 210 bar
- Wire mesh filter elements - series N: 20 bar
- Fluid flow through the filter element from OUT to IN

#### Seals

- Standard NBR series A
- Optional FPM series V

#### Temperature

From -25 °C to +110 °C

#### Connections

In-line Inlet/Outlet

#### Note

FMM filters are provided for vertical mounting



## Weights [kg] and volumes [dm<sup>3</sup>]

Filter series	Weights [kg]					Volumes [dm <sup>3</sup> ]						
	Length	1	2	3	4	5	Length	1	2	3	4	5
<b>FMM 050</b>		3.11	3.48	3.90	4.36	5.54		0.34	0.48	0.63	0.81	1.23
<b>FMM 150</b>		7.50	9.50	10.90	-	-		0.60	1.00	1.25	-	-

Filter series	Length	Filter element design - N Series						Filter element design - S Series				
		A03	A06	A10	A16	A25	M25	A03	A06	A10	A16	A25
<b>FMM 050</b>	<b>1</b>	42	43	79	82	106	147	29	39	57	59	74
	<b>2</b>	52	57	85	96	121	149	45	49	76	88	114
	<b>3</b>	66	69	97	106	130	150	58	61	89	99	125
	<b>4</b>	83	89	113	115	134	152	74	80	106	108	129
	<b>5</b>	107	110	130	134	141	154	93	95	111	121	139
<b>FMM 150</b>	<b>1</b>	81	88	156	163	179	295					
	<b>2</b>	142	145	227	230	236	312					
	<b>3</b>	170	180	242	245	263	315					

### Maximum flow rate for a complete pressure filter with a pressure drop $\Delta p = 1.5$ bar.

The reference fluid has a kinematic viscosity of 30 mm<sup>2</sup>/s (cSt) and a density of 0.86 kg/dm<sup>3</sup>.

For different pressure drop or fluid viscosity we recommend to use our selection software available on [www.mpfiltri.com](http://www.mpfiltri.com).

You can also calculate the right size using the formulas present on the FILTER SIZING paragraph at the beginning of the full catalogue or at the beginning of the filter family brochure. Please, contact our Sales Department for further additional information.

### Hydraulic symbols

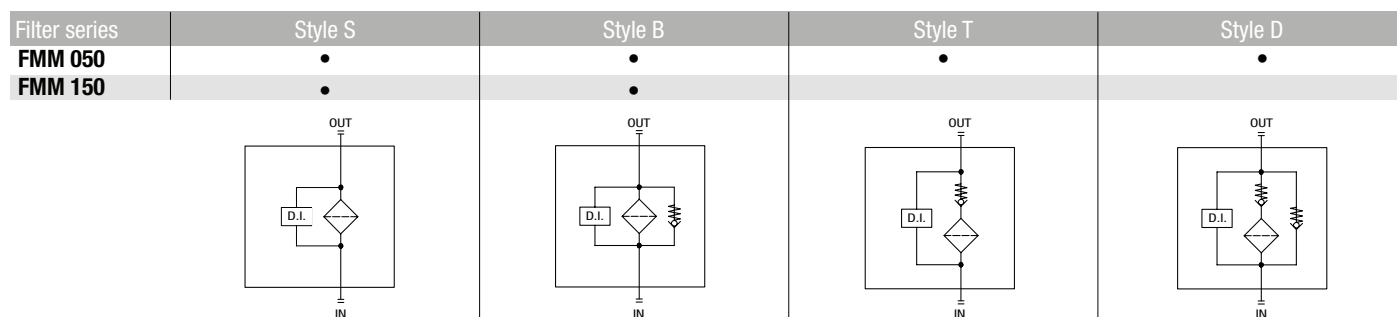

Pressure drop  
Filter housings  
 $\Delta p$  pressure drop

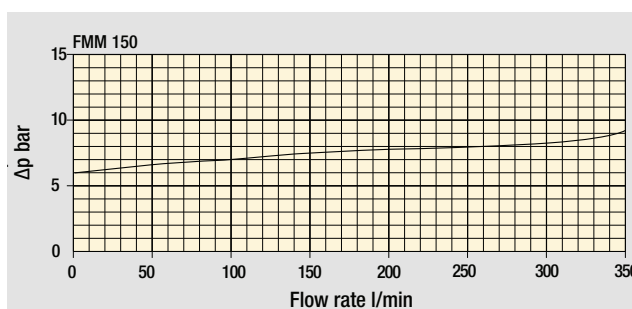
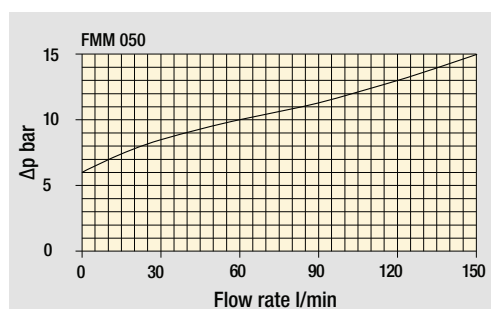
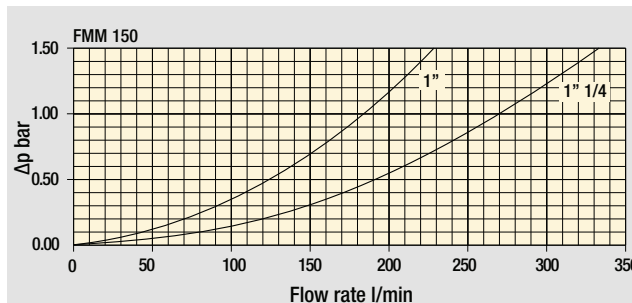
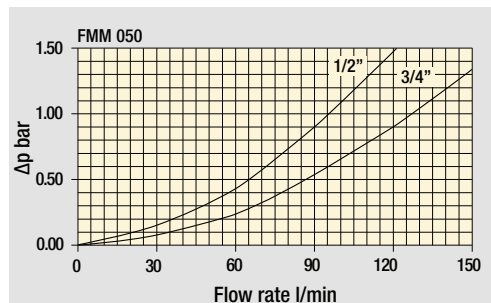

Bypass valve  
pressure drop

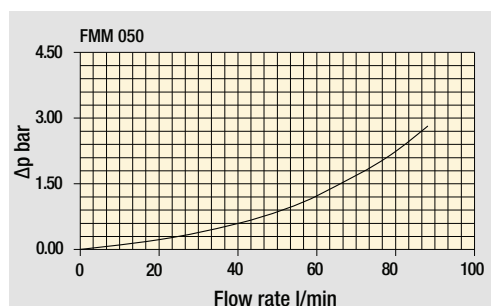

Filter housing  
with check valve

Valves

The curves are plotted using mineral oil with density of 0.86 kg/dm<sup>3</sup> in compliance with ISO 3968.  $\Delta p$  varies proportionally with density.

## Designation & Ordering code

### COMPLETE FILTER

Series and size Configuration example: **FMM050** | **3** | **B** | **A** | **G** | **A10** | **N** | **P01**

#### FMM050

#### Length

1 | 2 | 3 | 4 | 5

#### Valves

- S** Without bypass
- B** With bypass 6 bar
- T** With check valve, without bypass
- D** With check valve, with bypass 6 bar

#### Seals

- A** NBR
- V** FPM

#### Connections

- A** M18x1.5 - ISO 6149
- B** M22x1.5 - ISO 6149
- C** G 1/2"
- D** G 3/4"
- E** 1/2" NPT
- F** 3/4" NPT
- G** SAE 8 - 3/4" - 16 UNF
- H** SAE 12 - 1 1/16" - 12 UN

#### Filtration rating (filter media)

- A03** Inorganic microfiber 3 µm
- A06** Inorganic microfiber 6 µm
- A10** Inorganic microfiber 10 µm
- A16** Inorganic microfiber 16 µm
- A25** Inorganic microfiber 25 µm
- M25** Wire mesh 25 µm

Element Δp	Valves				
	S	B	T	D	
<b>N</b> 20 bar		•			
<b>R</b> 20 bar				•	
<b>S</b> 210 bar	•		•		

#### Execution

- P01** Upper connection for clogging indicator
- P02** Without connection for clogging indicator
- P03** Frontal connection for clogging indicator
- Pxx** Customized

### FILTER ELEMENT

Element series and size Configuration example: **HP050** | **3** | **A10** | **A** | **N** | **P01**

#### HP050

#### Element length

1 | 2 | 3 | 4 | 5

#### Filtration rating (filter media)

- A03** Inorganic microfiber 3 µm
- A06** Inorganic microfiber 6 µm
- A10** Inorganic microfiber 10 µm
- A16** Inorganic microfiber 16 µm
- A25** Inorganic microfiber 25 µm
- M25** Wire mesh 25 µm

Seals	
<b>A</b>	NBR
<b>V</b>	FPM

Element Δp	
<b>N</b>	20 bar
<b>R</b>	20 bar
<b>S</b>	210 bar

Execution	
<b>P01</b>	MP Filtri standard
<b>Pxx</b>	Customized

### ACCESSORIES

Differential indicators	page		page
<b>DEA</b> Electrical differential indicator	567	<b>DLE</b> Electrical / visual differential indicator	570
<b>DEH</b> Hazardous area electronic differential indicator	567-568	<b>DTA</b> Electronic differential indicator	571
<b>DEM</b> Electrical differential indicator	568-569	<b>DVA</b> Visual differential indicator	571
<b>DLA</b> Electrical / visual differential indicator	569-570	<b>DVM</b> Visual differential indicator	571

Additional features	page
<b>T2</b> Plug	572

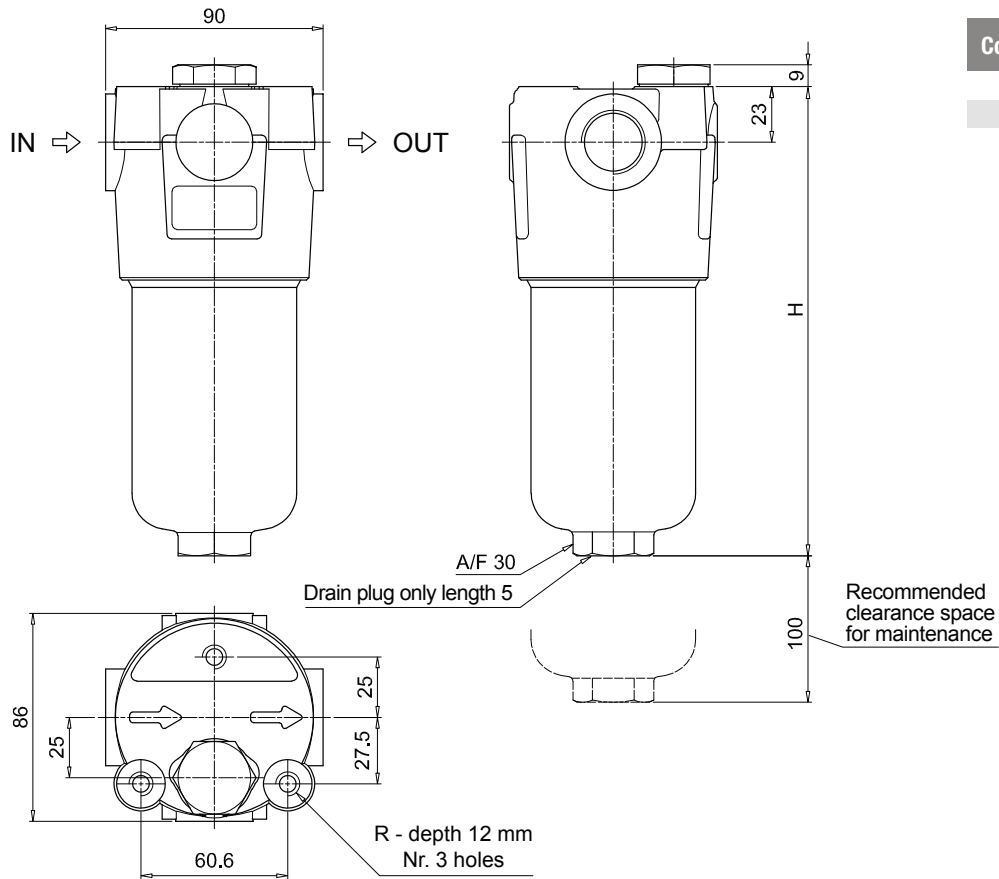

FMM050	
Filter length	H [mm]
1	158
2	195
3	237
4	285
5	407

Connections	R
A-B-C-D	M10
E-F-G-H	3/8" UNC

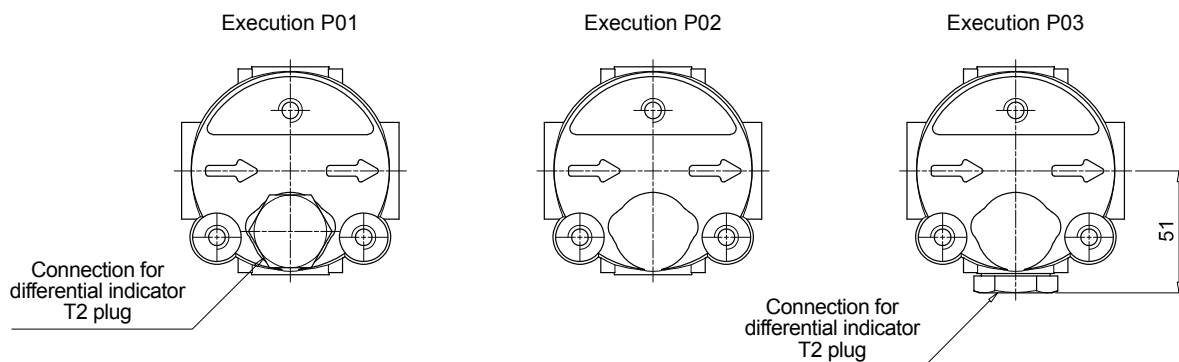

# FMM SPARE PARTS

Order number for spare parts

## FMM 050

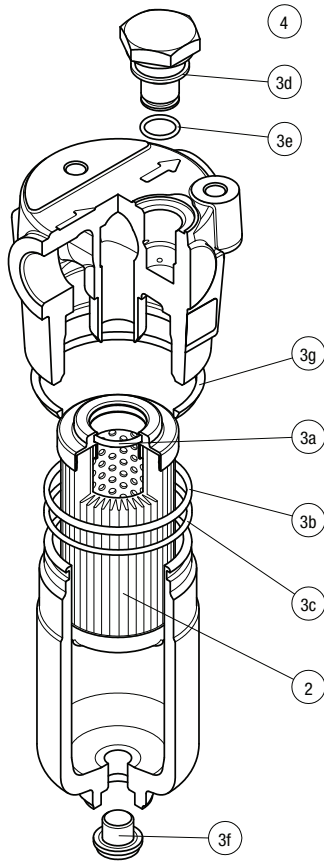

Item:	Q.ty: 1 pc. 2	Q.ty: 1 pc. 3 (3a ÷ 3g)	Q.ty: 1 pc. 4		
Filter series	Filter element	Seal Kit code number		Indicator connection plug	
	See order table	NBR	FPM	NBR	FPM
<b>FMM 050</b>	See order table	02050314	02050315	T2H	T2V

## FMM 150

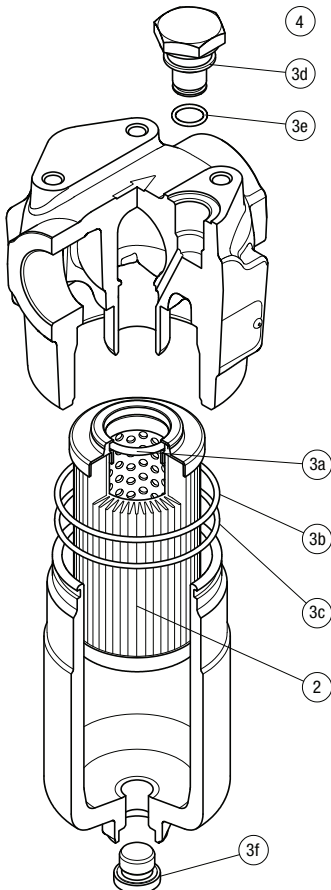

Item:	Q.ty: 1 pc. 2	Q.ty: 1 pc. 3 (3a ÷ 3f)	Q.ty: 1 pc. 4		
Filter series	Filter element	Seal Kit code number		Indicator connection plug	
	See order table	NBR	FPM	NBR	FPM
<b>FMM 150</b>	See order table	02050731	02050732	T2H	T2V