



Relief Valves Technical Information

Direct Acting

CP208-3

OPERATION

This is a direct-acting poppet type relief valve that relieves from 1 to 2.

SPECIFICATIONS

Theoretical performance

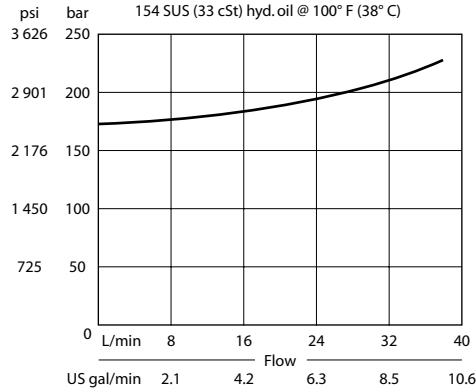

Schematic

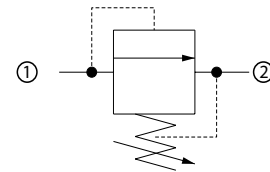

Specifications

Rated pressure	250 bar [3600 psi]
Rated flow	30 l/min [8 US gal/min]
Leakage	10 drops/min @ 80% of pressure setting
Weight	0.15 kg [0.32 lb]
Cavity	SDC08-2

DIMENSIONS

mm [in]

Cross-sectional view

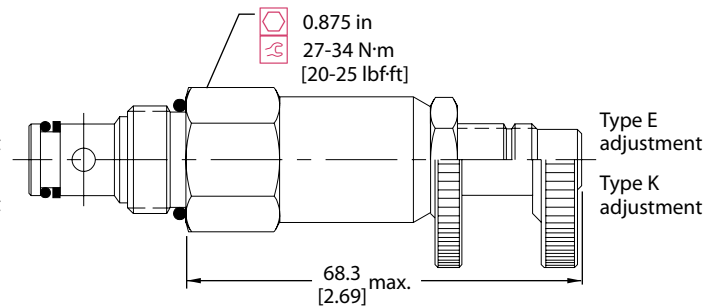
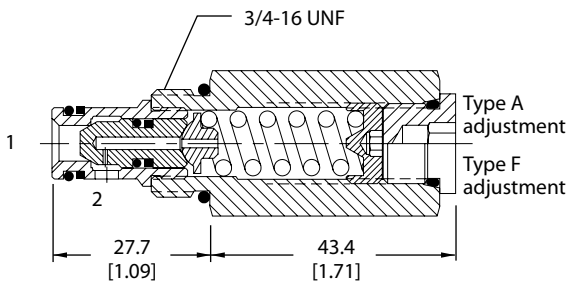

ORDERING INFORMATION

CP208 - 3 - B - 6S - A - C - 150

Seals	Seal Kit	Crack pressure	
B = Buna-N	120221	Code x 10 = psi	
V = Viton	120222	Example: 150 = 1500 psi	
Housing and ports	Housing P/N	Pressure range	
0 = No Housing	No Housing	A = 7-69 [100-1000]	[psi]
DG2B = Al, 1/4 BSP	SDC08-2-DG-2B	Standard = 28 [400]	
DG3B = Al, 3/8 BSP	SDC08-2-DG-3B	B = 14-138 [200-2000]	
4S = Al, #4 SAE	CP08-2-4S	Standard = 69 [1000]	
6S = Al, #6 SAE	CP08-2-6S	C = 35-248 [500-3600]	
Other housings available		Standard = 103 [1500]	
Adjustment option			
A = Internal			
E = External			
F = Tamper resistant			
K = Knob			